



FLUKA developments

Francesco Cerutti



on behalf of the FLUKA.CERN Collaboration

Outline

- FLUKA (yesterday and) today
- some highlights
- FLUKA tomorrow

Four software generations, preparing for the fifth

PROGRAM NAME : FLUKA
FUNCTION : Calculation of energy deposition and star densities in a cylindrical block.

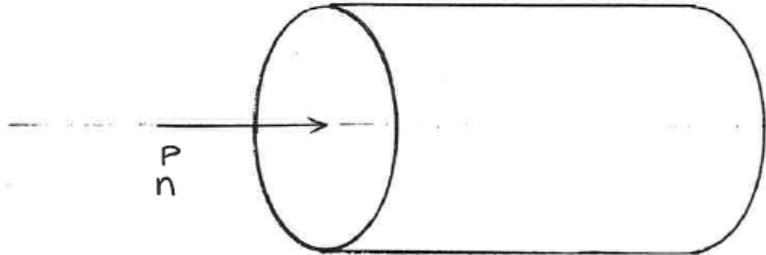

From 2003 until August 2019 maintained and developed under a **CERN & INFN** agreement

www.fluka.org

Born in the 60's at **CERN** thanks to **Johannes Ranft** and developed in the 70s (I) and 80s (II) in a collaboration between **Leipzig University**, **CERN** and **Helsinki University of Technology**

EXAMPLE OF CONTROL AND DATA CARDS

```
X5SHF,T300,                                FLUKAINPUT
ACCOUNT,NAME,PRIV,000000,
ATTACH,LIB,7600LIBRARY,
LIBRARY,LIB,
ATTACH,BMAIN,FLUKA,ID=SP070CASC,ST=CCP,
ATTACH,BCASCA,CASCA,ID=SP070CASC,ST=CCP,
LOAD,BMAIN,BCASCA,
EXECUTE,,PL=4000,
EXIT,
END OF RECORD CARD

LSR BEAM DUMP  INNER CYLINDER  FLUKA
400,          0,5
          612,          2,3
00000000001400000100
9,2          0,023
0,8
STUP
END OF FILE CARD
```

and in the 90s (III) with **INFN**, namely for the design of SSC and LHC

From December 2019, new **CERN** distribution (IV) aiming to ensure FLUKA's long-term sustainability and capability to meet the evolving requirements of its user community, welcoming contributions by both established FLUKA contributors as well as new partners within an **international collaboration**.

<https://fluka.cern>

FLUKA.CERN collaboration

VS - 2021/5

MEMORANDUM OF UNDERSTANDING
FOR
THE DEVELOPMENT, MAINTENANCE AND
DISTRIBUTION
OF
THE FLUKA.CERN SOFTWARE
(the "MoU")

BETWEEN

THE EUROPEAN ORGANIZATION FOR NUCLEAR RESEARCH ("CERN" or "the Host Organisation"), an Intergovernmental Organization having its seat at Geneva, Switzerland,

AND

THE MEMBER INSTITUTES OF THE COLLABORATION (the "Member Institutes")

hereinafter referred to individually as a "Party" or collectively as "Parties";

CONSIDERING THAT:

- A. FLUKA.CERN, a fully integrated particle physics Monte-Carlo simulation software package with multiple applications in high energy experimental physics, as well as in engineering, shielding, detector and telescope design, cosmic ray studies, dosimetry, medical physics and radio-biology, results from work performed by multiple contributors, including Alberto Fassò, Alfredo Ferrari, Johannes Ranft, and Paola Sala.
- B. To a significant extent, FLUKA.CERN was developed by a collaboration of CERN and the Italian National Institute for Nuclear Physics ("INFN"). Accordingly, copyright in developments to FLUKA.CERN made until 31 August 2019 is vested in the INFN and CERN jointly, while copyright in further developments made as of 1 September 2019 is vested in CERN.

Collaboration Board (CB)

Scientific Advisory Committee (SAC)

Joint development & management team based in the **CERN Accelerators and Technology Sector and Radiation Protection Group**, at **ELI-Beamlines ERIC (Prague)** and [pending MoU signature] **FNAL**, with contributors from the CERN Research and Computing Sector, JRC-Geel, ANL, BNL, and STFC, is in place.

WP1 ACTIVITY MANAGEMENT

(Francesco Cerutti & Philippe Schoofs, CERN ATS-SY-STI)

WP2 CODE DEVELOPMENT

(Vasilis Vlachoudis & Francesc Salvat Pujol, CERN ATS-SY-STI)

WP3 CODE DEVELOPMENT SUPPORT

(Robert Froeschl & Markus Widorski, CERN SO-HSE-RP)

WP4 USER SUPPORT

(Roberto Versaci & David Horvath, ELI Beamlines)

Licensing Scheme

Registration options

FLUKA Single User License Agreement

Affiliates of institutes with a **FLUKA Institutional License Agreement**

CERN Staff members and Fellows

Affiliates of institutes which signed the **FLUKA Memorandum of Understanding**

Companies which purchased a **FLUKA Commercial License Agreement**

giving access to:

binary code

source code

development version

binary code

STFC

Licenses are free except for commercial use

They are granted for **non-military use** only

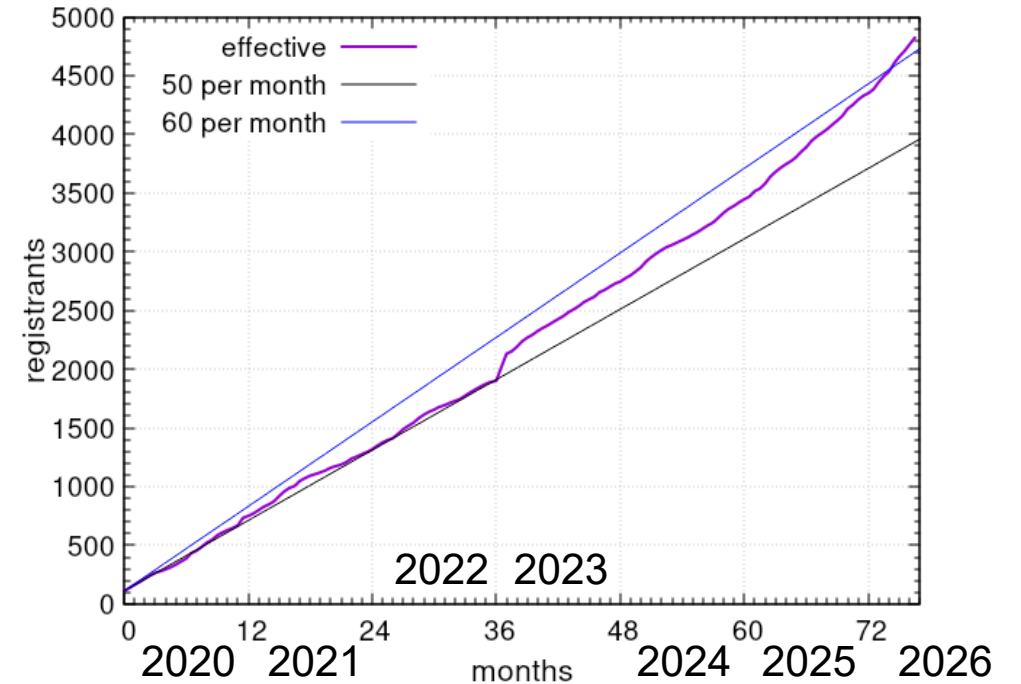

Recent developments

Coherent transport effects for charged particles in **bent crystals**; electric field in vacuum; electronuclear reactions; direct (p,n) reactions.

Compound nucleus spin and parity accounted for in evaporation and Fermi break-up; **new generation source** routine for users.

Low-energy **deuteron interaction** model; proton reaction cross section refinement; ICRP116 and ICRU95 dose equivalent conversion coefficients; simplified out-of-the-box usage of multiple magnetic fields.

Point-wise treatment for **low-energy neutron** interactions; **synchrotron radiation** emission during charged particle tracking.

Proton nuclear elastic scattering improvement at low energies; gamma cascade improvement for thermal neutron capture; (d,2n) improvement on heavy targets.

Support for **unstructured-mesh geometries** (externally generated from CAD models); Automatic Importance Biasing; major extension of correlated gamma emission spectra from thermal neutron capture; inclusion of physics modules migrated to v5

*FLUKA 2011-3 released on **December 2019***

FLUKA 4-0** released on **June 2020

*FLUKA 4-0.1 released on **August 2020***

*FLUKA **4-1** released on **November 2020***

*FLUKA 4-1.1 released on **February 2021***

*FLUKA **4-2** released on **October 2021***

*FLUKA 4-2.1 released on **December 2021***

*FLUKA 4-2.2 released on **March 2022***

*FLUKA **4-3** released on **September 2022***

*FLUKA 4-3.1 released on **December 2022***

*FLUKA 4-3.2 released on **March 2023***

*FLUKA 4-3.3 released on **May 2023***

*FLUKA 4-3.4 released on **September 2023***

*FLUKA **4-4** released on **February 2024***

*FLUKA 4-4.1 released on **July 2024***



















*FLUKA **4-5** released on **February 2025***

*FLUKA 4-5.1 released on **September 2025***

*FLUKA 4-5.2 released on **May 2026***

The most recent references

New Capabilities of the FLUKA Multi-Purpose Code

 C. Ahdida¹,  D. Bozzato^{1,2},  D. Calzolari¹,  F. Cerutti^{1*},  N. Charitonidis¹,  A. Cimmino³,  A. Coronetti^{1,4},  G. L. D'Alessandro¹,  A. Donadon Servelle^{1,5},  L. S. Esposito¹,  R. Froeschl¹,  R. García Alía¹,  A. Gerbershagen¹,  S. Gilardoni¹,  D. Horváth³,  G. Hugo¹,  A. Infantino¹,  V. Kouskoura¹,  A. Lechner¹, B. Lefebvre³, G. Lerner¹, M. Magistris¹, A. Manousos^{1,6}, G. Moryc¹, F. Ogallar Ruiz^{1,7}, F. Pozzi¹, D. Prelicpean^{1,8}, S. Roesler¹, R. Rossi¹, M. Sabaté Gilarte¹, F. Salvat Pujol¹, P. Schoofs¹, V. Stránský³, C. Theis¹, A. Tsinganis⁹, R. Versaci³, V. Vlachoudis¹, A. Waets¹ and M. Widorski¹

ORIGINAL RESEARCH article

Front. Phys., 27 January 2022 | <https://doi.org/10.3389/fphy.2021.788253>

¹European Organization for Nuclear Research (CERN), Geneva, Switzerland

²Karlsruhe Institute of Technology (KIT), Karlsruhe, Germany

³ELI Beamlines Centre, Institute of Physics, Czech Academy of Sciences, Dolní Břežany, Czech Republic

⁴Department of Physics, University of Jyväskylä, Jyväskylä, Finland

⁵Ecole Polytechnique Fédérale de Lausanne, Institute of Physics, Lausanne, Switzerland

⁶Department of Physics, Aristotle University of Thessaloniki, Thessaloniki, Greece

⁷Department of Atomic, Molecular and Nuclear Physics, University of Granada, Granada, Spain

⁸Department of Physics, Technical University of Munich (TUM), Munich, Germany

⁹European Commission, Joint Research Centre (JRC), Geel, Belgium

Open Access

EPJ Nuclear Sci. Technol. 10, 20 (2024)

<https://doi.org/10.1051/epjn/2024023>

Regular Article

Latest FLUKA developments





 Gabrielle Hugo^{1*},  Claudia Ahdida¹,  Davide Bozzato¹,  Daniele Calzolari^{1,2},  Francesco Cerutti¹,  Alessia Ciccotelli^{1,3},  Anna Cimmino⁴,  Arnaud Devienne¹,  Andre Donadon Servelle^{1,5},  Patrycja K. Dyrz¹,  Luigi Salvatore Esposito¹,  Alice Formento¹,  Robert Froeschl¹,  Ruben García Alía¹,  Simone Gilardoni¹,  Andrea Gomes¹,  Dávid Horváth⁴, Barbara Humann¹, Angelo Infantino¹, Anton Lechner¹, Benoit Lefebvre⁴, Giuseppe Lerner¹, Tommaso Lorenzon¹, David Lucsanyi^{1,6}, Matteo Magistris¹, Stefano Marin¹, Giuseppe Mazzola¹, Samuel Niang¹, Elzbieta Nowak¹, Francisco Ogallar Ruiz^{1,7}, Jean-Baptiste Potoine^{1,6}, Fabio Pozzi¹, Daniel Prelicpean^{1,8}, Volodymyr Rodin¹, Stefan Roesler¹, Marta Sabaté Gilarte¹, Mario Sacristan Barbero^{1,6}, Francisc Salvat Pujol¹, Philippe Schoofs¹, Alexandra-Gabriela Șerban^{1,9}, Ivan Sharankov¹⁰, Chris Theis¹, Marco Tisi¹, Andrea Tsinganis¹¹, Roberto Versaci⁴, Vasilis Vlachoudis¹, Andreas Waets^{1,12}, Markus Widorski¹ and Illia Zymak⁴

TABLE OF CONTENTS

Abstract

1 Introduction

2 New Physics Developments

3 Flair, the FLUKA User Interface

4 Radiation to Electronics

5 Code Testing and Benchmarking

6 Outlook

Data Availability Statement

Author Contributions

Conflict of Interest

Publisher's Note

Acknowledgments

Footnotes

References

¹ European Organization for Nuclear Research (CERN), Geneva, Switzerland

² University of Padova, Department of Physics and Astronomy, Padova, Italy

³ University of Manchester and Cockcroft Institute, Department of Physics and Astronomy, School of Natural Sciences, Oxford Road, Manchester, M13 9PL, United Kingdom

⁴ The Extreme Light Infrastructure ERIC, ELI Beamlines Facility, Za Radnici 835, 252 41 Dolní Břežany, Czech Republic

⁵ Ecole Polytechnique Fédérale de Lausanne (EPFL), Institute of Physics, Lausanne, Switzerland

⁶ University of Montpellier, Institute of Electronics and Systems, Montpellier, France

⁷ University of Granada, Department of Atomic, Molecular and Nuclear Physics, Granada, Spain

⁸ Technical University of Munich (TUM), Department of Physics, Munich, Germany

⁹ Faculty of Physics, University of Bucharest, and "Horia Hulubei" National Institute of Physics and Nuclear Engineering, Bucharest-Magurele, Romania

¹⁰ Uppsala University, Department of Physics and Astronomy, Uppsala, Sweden

¹¹ European Commission, Joint Research Centre (JRC), Geel, Belgium

¹² University of Zurich (UZH), Physik-Institut, Zurich, Switzerland

Quality assurance

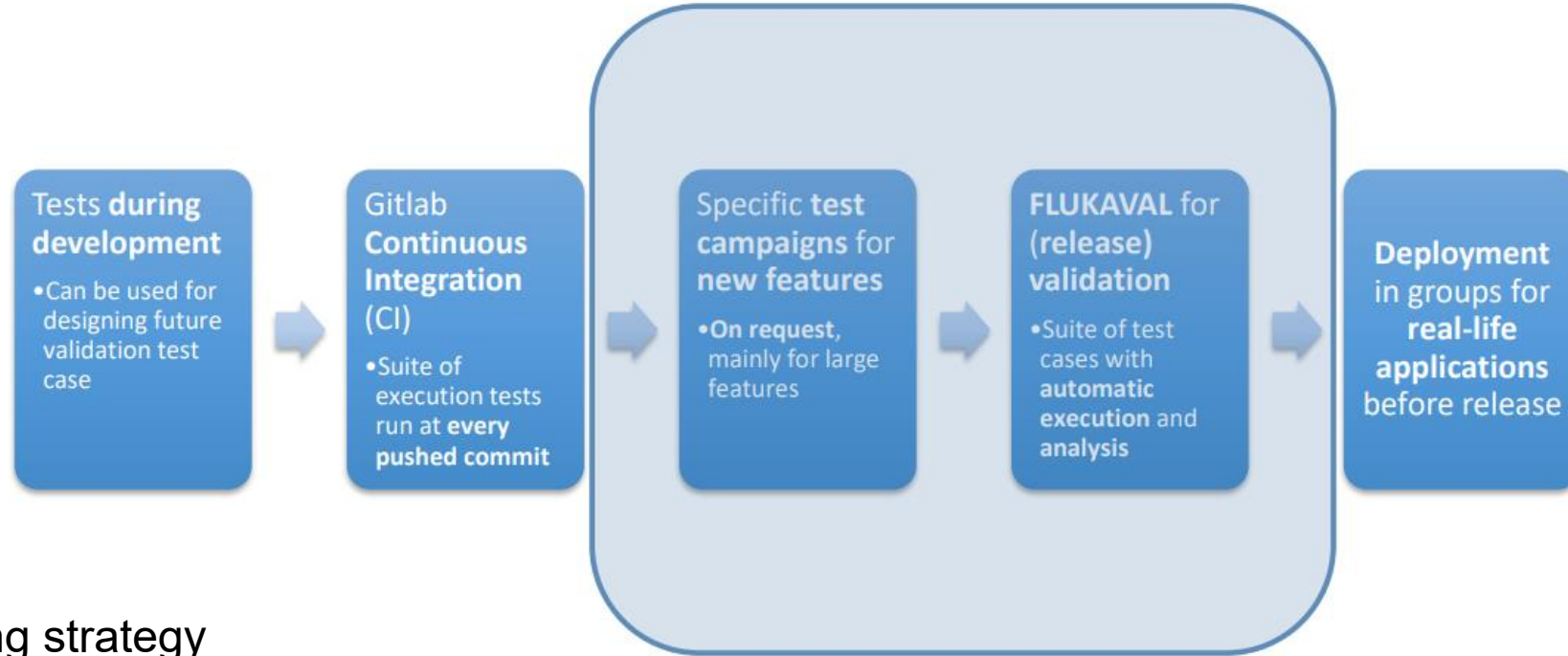

- Multi-layered testing strategy
- Dedicated validation suite, called **FLUKAVAL**, with several hundreds test cases and detailed reports prior to public release
- *Regression checks among releases*, benchmarks against experimental data, MC results inter-comparisons
- Generic infrastructure: FLUKA v4 and v5 support

User Support

FLUKA User Forum

<https://cern.ch/fluka-forum>

FLUKA Training

<https://indico.cern.ch/category/9178>

Beginner and **advanced** courses are held on a regular basis across the world



FLUKA Advanced Course 2025
ALBA Synchrotron, Barcelona



Topical courses (so far on Radiation Protection matters) have been initiated: *the next one at DESY in September*

Category	Count
Announcements	1 / week
As of December 2019, this discussion list represents the official forum for users of the FLUKA Monte Carlo code and its graphical user interface Flair, distributed by the European Organization for Nuclear Research (CERN).	
Installation	1 / week
Category for questions related to the installation of FLUKA and Flair.	
Flair	1 / week
Category for questions related to the graphical user interface Flair.	
Running and Runtime Errors	4 / week
Category for questions related to running FLUKA and Flair.	
Source Definition	220
Category for questions concerning built-in source options, like particle beams, hadron-hadron collisions or isotropic sources.	
Geometry and Materials	3 / week
Category for material and geometry-related questions including topics like transformations and lattices.	
Scoring	2 / week
Category for questions related to built-in scoring options.	
Physics, Transport and Magnetic Fields	271
Category for physics-related questions, as well as questions on transport and magnetic field settings.	
Advanced Features and User Routines	2 / week
Category for questions on biasing, user routines, and other advanced features.	
FLUKA - Geant4 Interface	2
Questions on the FLUKA-Geant4 interface, which gives access to the FLUKA hadron inelastic interaction treatment from any Geant4 application.	
FLUKA papers	1 / week
This category offers the FLUKA.CERN users the possibility to share their published papers and	

F Release of FLUKA 4-4.1	1
Announcements	5 Jul
T IMPORTANT: Registration and package download FAQ	2
Installation	Nov 2022
T Water HVL with iodine131	1
Physics, Transport and Magnetic Fields	6h
T How to read Fluka Output file	1
Running and Runtime Errors	6h
T Fluka can implement a 'for loop' ? like C++	1
Running and Runtime Errors	6h
T How to understand the tab.lis file of the USRBDX output?	9
Scoring	7h
C Error with DISCARD card	4
Running and Runtime Errors	8h
K **** No/unknown default specified, run stopped ****	2
Running and Runtime Errors	9h
K Getting a floating point error when running the example	4
Installation	9h
T Particle age sampling- difference between the sampling source and the output	1
Advanced Features and User Routines	1d
T Using mgdraw.f for photon source	1
Advanced Features and User Routines	2d
T Error: in position *** is now causing trouble, requesting a step of *** cm	1
Geometry and Materials	2d

Note: an independent one-time registration is required to be able to participate

<https://flair.cern>

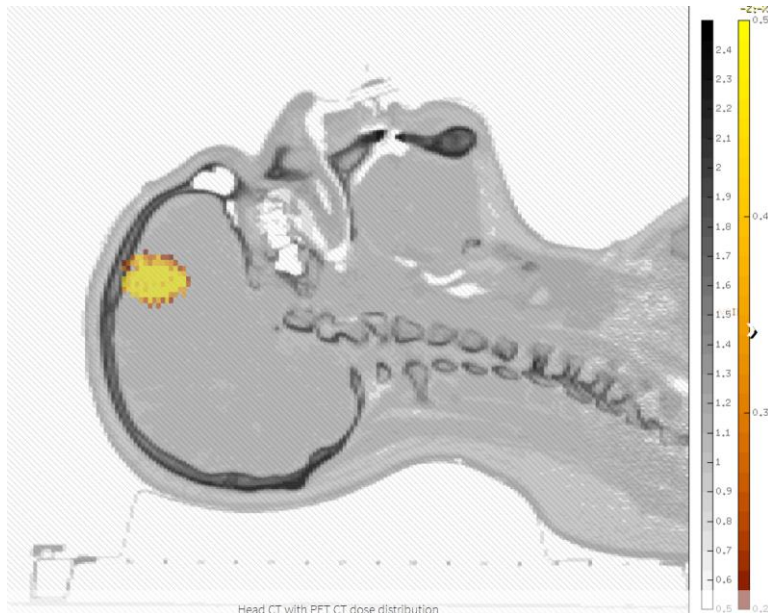
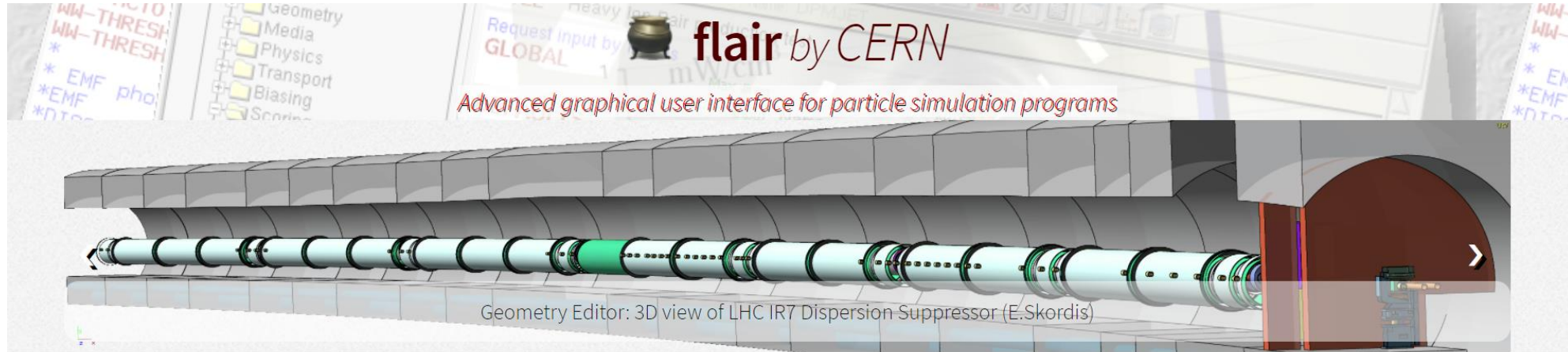

Authors

authors: Vasilis Vlachoudis (*lead author*)
Christian Theis
Wioletta Kozłowska

Current Version

- Latest version: 3.4-5.3
- Released on: *Tue 26-May-2026*
- Powered by python3, tkinter, gnuplot, pydicom

Features

- modern and intuitive design
- Input editor for error free inputs
- Interactive geometry editor, photorealistic ray tracer and debugger
- run and monitor the simulation
- back-end for post-processing of results
- I/O of other simulation formats (MCNPX,GDML,...)
- Medical file importing, DICOM, RT-PLAN,DOSE,...
- extended material library

LineBuilder

LineBuilder is a Python program designed to dynamically assemble FLUKA models of accelerator beam lines. It automatically configures element positions, magnetic fields, and scoring definitions, while allowing users to specify detailed geometric features such as collimator apertures, element tilts and misalignments, beam pipes, and tunnel geometries.

At CERN, it has been widely used for beam-machine interaction studies, notably for the LHC and SPS.

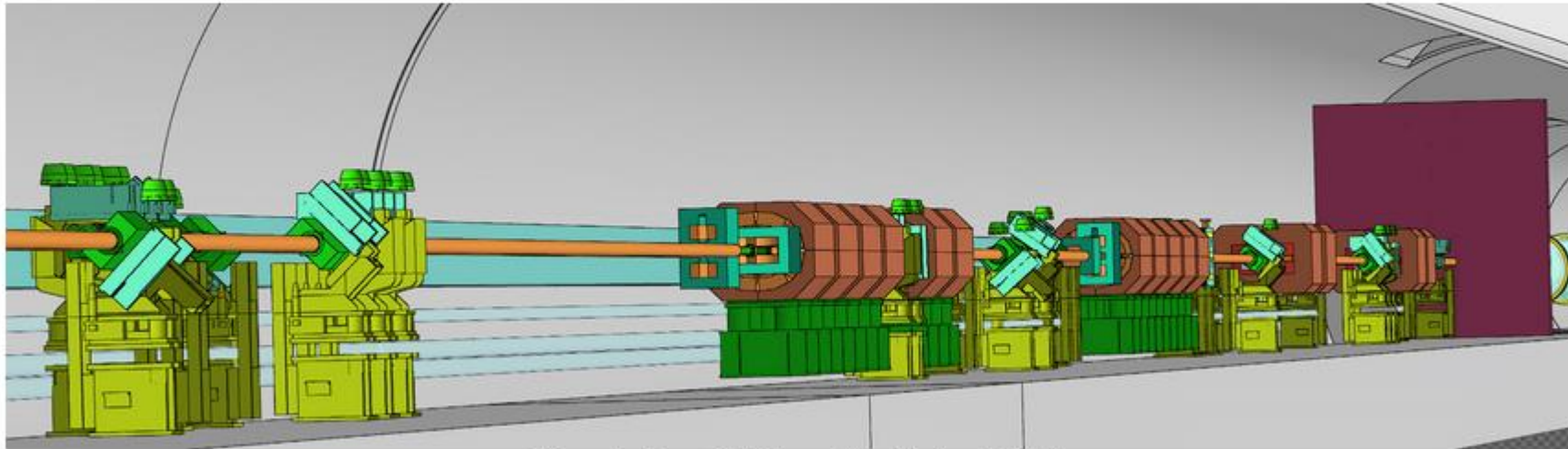

3D rendering of LHC Insertion Region 7 (IR7)

LineBuilder Single User Licence Agreement (*academic or educational use*)

[A. Mereghetti et al.,
IPAC2012, WEPPD071, 2687]

From DETAILED MODELS OF ACCELERATOR COMPONENTS WITH ASSOCIATED SCORING and the ELEMENT SEQUENCE AND RESPECTIVE MAGNETIC STRENGTHS, as given IN THE MACHINE OPTICS (TWISS) FILES, the **AUTOMATIC CONSTRUCTION OF COMPLEX BEAM LINES**, including collimator settings and element displacement (BLMs), is achievable, profiting from roto-translation directives and replication (lattice) capabilities.

FLUKA capabilities

- hadron-hadron and hadron-nucleus interactions
- nucleus-nucleus interactions (including deuterons!)
- photon interactions (>100 eV)
- electron interactions (> 1 keV; including electronuclear)
- muon interactions (including photonuclear)
- neutrino interactions
- low energy (<20 MeV) neutron interactions
- particle decay
- ionization and multiple (single) scattering (including all ions down to keV/u)
- synchrotron radiation emission
- coherent effects in crystals (channelling)
- magnetic field, and electric field in vacuum
- combinatorial geometry and lattice capabilities
- unstructured meshes from CAD models
- voxel geometry and DICOM importing
- analogue or biased treatment
- on-line buildup and evolution of induced radioactivity and dose
- built-in scoring of many quantities (... , DPA, eq. dose)

In support of a
wide range of applications

- ✓ Accelerator design
- ✓ Particle physics
- ✓ Cosmic ray physics
- ✓ Neutrino physics
- ✓ Medical applications

- ✓ Radiation protection (shielding design, activation)
- ✓ Dosimetry
- ✓ Radiation damage
- ✓ Radiation to electronics effects
- ✓ ADS systems, waste transmutation
- ✓ Neutronics

Unstructured meshes utils

- Unstructured meshes are supported from FLUKA v4-5.0 onward. Please have a look at [our general guide](#) on the matter [here](#).

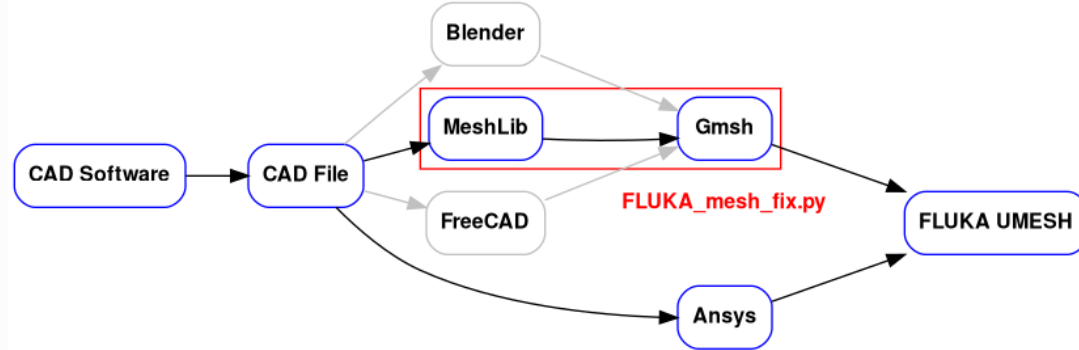

- A necessary pre-requisite is the conversion of your CAD geometries into an unstructured mesh format which can be digested by FLUKA. While a range of open-source and commercial tools is available to perform such a conversion (such as Ansys), we **provide a script to help you convert your CAD geometry and trouble-shoot potential issues**. The script directly makes use of open-source tools. It is available for download in the *geom_mesh_utils* package below, along with a set of geometries examples.

Download: [geom_mesh_utils.tar.gz](#)

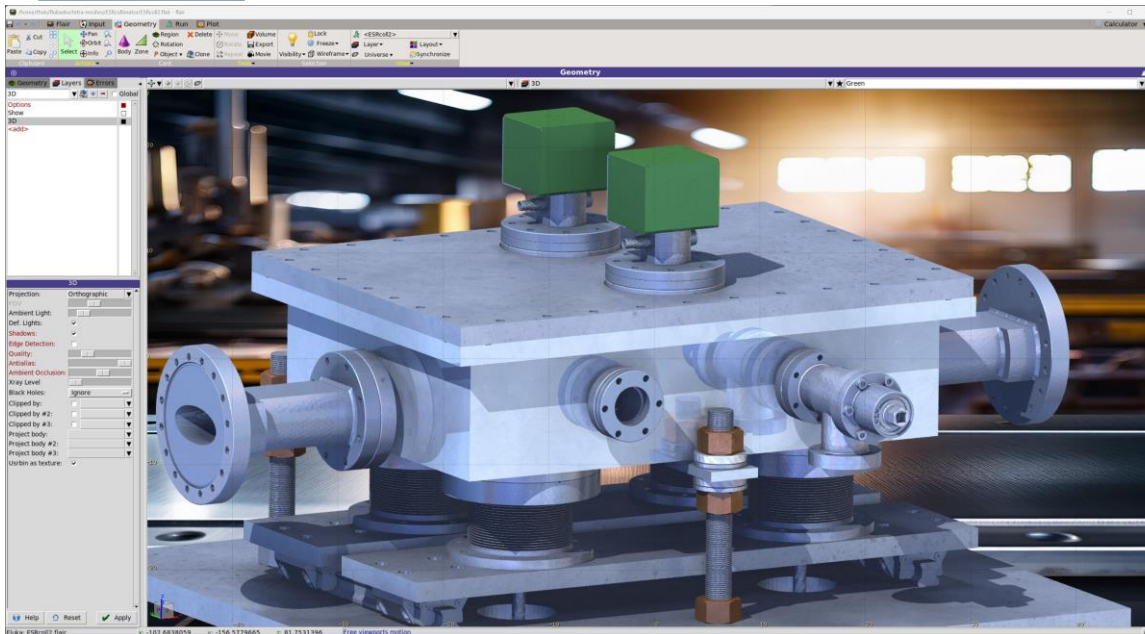

Unstructured meshes mini guide

Table of contents

- 1. Introduction
 - 1.1. Glossary
 - 1.2. Getting started
 - 1.3. Basic suggestions for CAD model preparation
- 2. Basic requirements for 2D and 3D meshes
 - 2.1. Fixing problematic 2D meshes
- 3. Generation
 - 3.1. Overview
 - 3.2. 3D meshing via Gmsh API
 - 3.3. Guide for the meshing script
 - 3.4. Guide for meshing in Ansys
- 4. Application
 - 4.1. Single mesh
 - 4.2. Multiple meshes
 - 4.3. Lattice of UMESH
 - 4.4. Scoring inside mesh
- 5. Troubleshooting

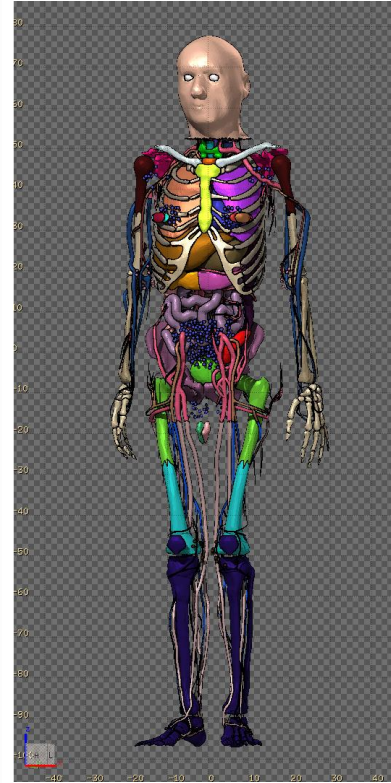

ICRP P145 phantom

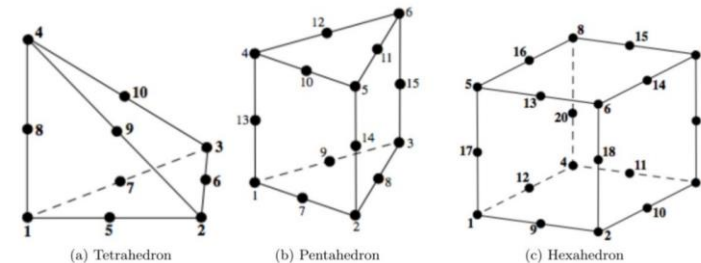

Neutrons

Below 20 MeV (“**low energy neutrons**” in FLUKA slang), cross sections exhibit a rich structure of **resonances** that no effective model can describe in a systematic way. One must resort to *evaluated nuclear data* (for both group- and point-wise approaches).

Below ~eV energies, cross sections become sensitive to local atomic arrangement, neutrons scatter coherently on molecules / crystal lattice, calling for the use of **thermal scattering laws $S(\alpha,\beta,T)$** :

enabled by default only for HYDROGEN (assumed to be bound in water) and on user demand (**LOW-PWXS**) for other cases/materials

- Energy limit **4 eV**
- About ~50 scattering environments available, at fixed T
- Format accepted: Geant4 and/or ACE (point wise)

FLUKA interface to Ncrystal under development

Dynamic linking **libNCrystal.so** library during run time resolved with the **ncrystal-config** program

New NCRYSTAL card

 **NCRYSTAL** Mat: CARBON ▼ Elimit:
cfg: C_sg194_pyrolytic_graphite.ncmat;temp=20C

Mat: FLUKA material

E_{limit}: transition limit, default = 5 eV

cfg: NCrystal configuration string

Radiation damage estimation

DPA: displacements per atom. Key quantity: number of ion-hole pairs per knock-on atom, $N(T_d)$.

Industry standard: **NRT model** (old binary collision simulations – no effort to account for recombination)

As of v4-3, athermal recombination efficiency (arcDPA):

NATURE COMMUNICATIONS | (2018)9:1084

Improving atomic displacement and replacement calculations with physically realistic damage models

Kai Nordlund¹, Steven J. Zinkle^{2,3}, Andrea E. Sand¹, Fredric Granberg¹, Robert S. Averback⁴, Roger Stoller³, Tomoaki Suzudo⁵, Lorenzo Malerba⁶, Florian Banhart⁷, William J. Weber^{3,8}, Francois Willaime⁹, Sergei L. Dudarev¹⁰ & David Simeone¹¹

$$N_{d,arcDPA}(T_d) = \begin{cases} 0 & , T_d < E_d \\ 1 & , E_d < T_d < \frac{2E_d}{0.8} \\ \frac{0.8T_d}{2E_d} \xi_{arcDPA}(T_d) & , \frac{2E_d}{0.8} < T_d < \infty \end{cases}$$

$$\xi_{arcDPA}(T_d) = \frac{1 - c_{arcDPA}}{(2E_d/0.8)^{b_{arcDPA}}} T_d^{b_{arcDPA}} + c_{arcDPA}$$

Norgett-Robinson-Torrens (NRT)

$$N_d(T_d) = \begin{cases} 0 & , T_d < E_d \\ 1 & , E_d < T_d < \frac{2E_d}{0.8} \\ \frac{0.8T_d}{2E_d} & , \frac{2E_d}{0.8} < T_d < \infty \end{cases}$$

800 MeV protons in W

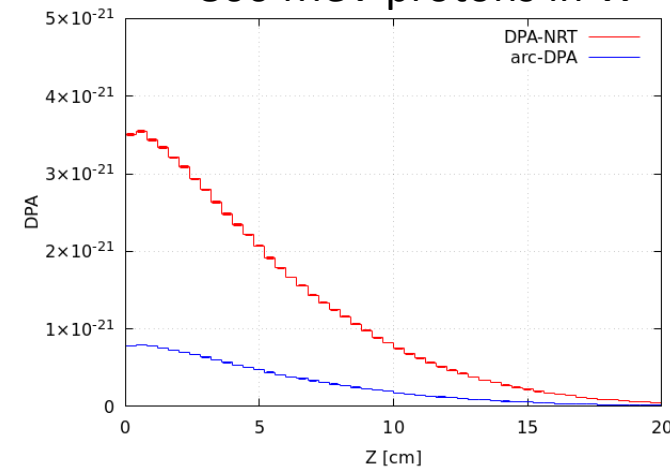

Muons

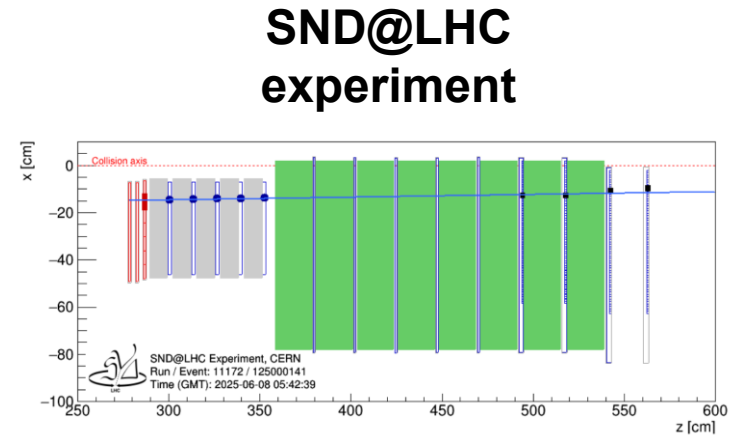
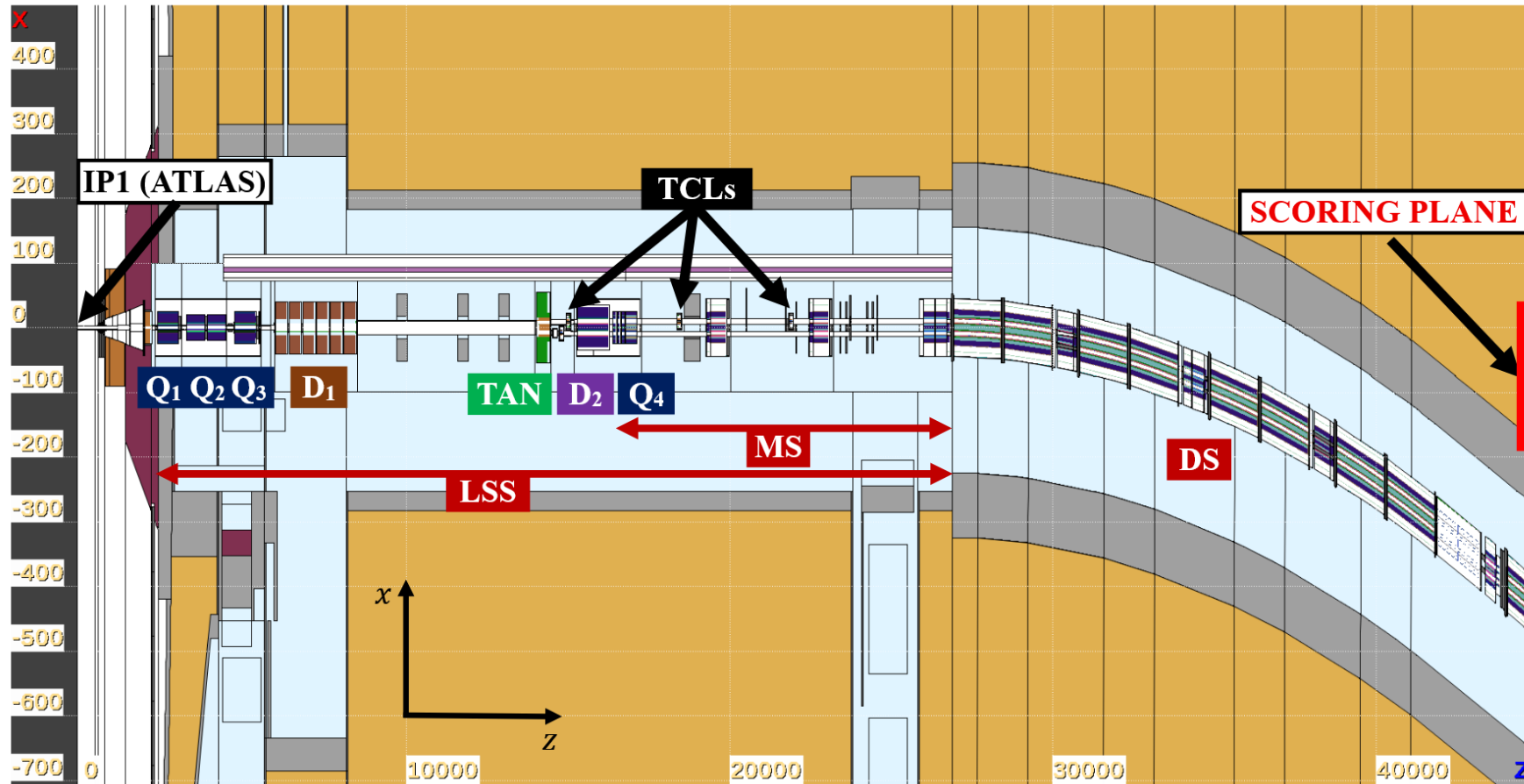

Table 2 SND@LHC muon background during the Run-3 years: measured and simulated rates at $\mathcal{L} = 2 \times 10^{34} \text{ cm}^{-2} \text{ s}^{-1}$, with respective statistical uncertainties, and percentage differences.

	2022–2023	2024	2025
Φ_{exp} (Hz)	557 ± 1	1154 ± 2	799 ± 1
Φ_{MC} (Hz)	500 ± 17	1008 ± 35	907 ± 40
δ	-10%	-12.5%	+13.5%

Towards the next FLUKA (v5) generation [I]

FLUKA has reached a high level of maturity. It has been used and benchmarked for the design / construction / operation of accelerators over several decades.

Nonetheless, the present FLUKA (v4) codebase, mostly in FORTRAN 77, naturally calls for:

- Improving maintainability (limit the use of modifiable shared variables; explicit variables declaration and initialization; modularize the code structure; etc.)
- Increasing code readability
- Profiting from modern programming languages
- Modern memory management
- More explicit error messages

We aim at improving FLUKA physics performance and its user experience, long-term maintenance, easing incorporation of new implementations, openness to external contributions.

Towards the next FLUKA (v5) generation [II]

Full re-writing from scratch would be too time-consuming / leading to redundant work.

A progressive, hybrid solution was chosen:

Make use of the *Geant4 toolkit*. Build on top an **infrastructure** providing the same capabilities as FLUKA v4.

Geant4 physics models and technical capabilities are adopted when they align with those of FLUKA, otherwise, they are temporarily used until the migration of their FLUKA v4 counterparts is completed. When equivalent performance is reached, release as FLUKA v5.

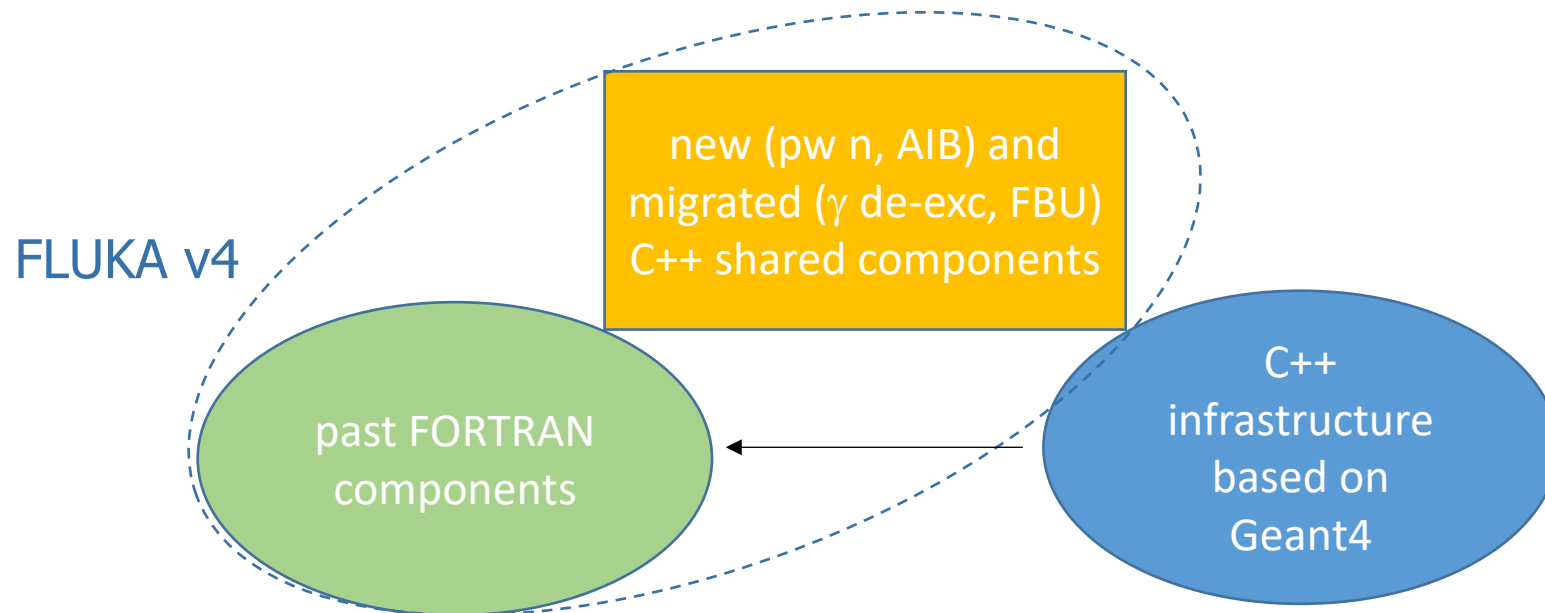

The migration status

The present FLUKA v5 infrastructure already grants *access to current FLUKA* physics modules, namely *hadron-nucleus inelastic interactions*, *ion-ion inelastic interactions*, and *pointwise treatment of low-energy neutrons interactions*.

In parallel, the following physics modules were / are being *migrated*: *de-excitation of excited residual nuclei by gamma decay*, *Fermi breakup of excited nuclei*, *nuclear fission*.

It's **not** a mere *language translation*, rather the opportunity to thoroughly assess and document implemented algorithms, modularize the code and develop common utilities (helper tools, wrappers to v4 and v5 codebases, utilities to interface FLUKA ↔ Geant4 worlds as for particles identification, random numbers...), improve physics models, fix bugs, evaluate the use of Geant4 toolkit when relevant, and improve computing performance when possible.

Moreover, *FLUKA v5* – distributed within the Collaboration – presently *supports most of FLUKA v4 geometry features*, *magnetic fields* (multipoles, 2D/3D interpolated fields, user-defined fields) and *extended scoring options* (including radioactive decay modeling with irradiation profiles and cooling times, and event-by-event and Single Event Effects scoring).

The future FLUKA v5

A fully integrated, ready-to-run application offering continuity to the FLUKA users, with **one** well-defined set of physics models for coupled hadronic and electromagnetic showers.

Compatibility with previous FLUKA v4 geometries and input files permitted by Flair conversion scripts and a technical infrastructure offering continuity with v4 features via dedicated implementations (geometry & navigation, scoring, biasing...). Compatibility with FLUKA auxiliary tools (e.g. LineBuilder).

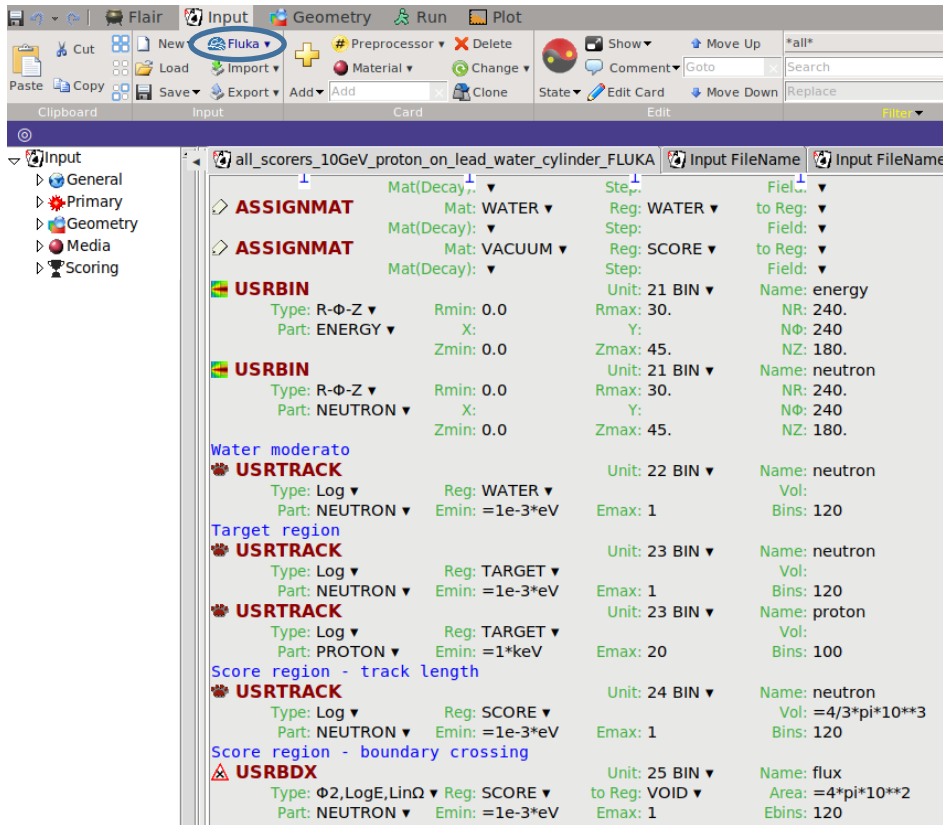

*automatic (irreversible)
conversion by Flair*



**additional access to
Geant4 physics lists**

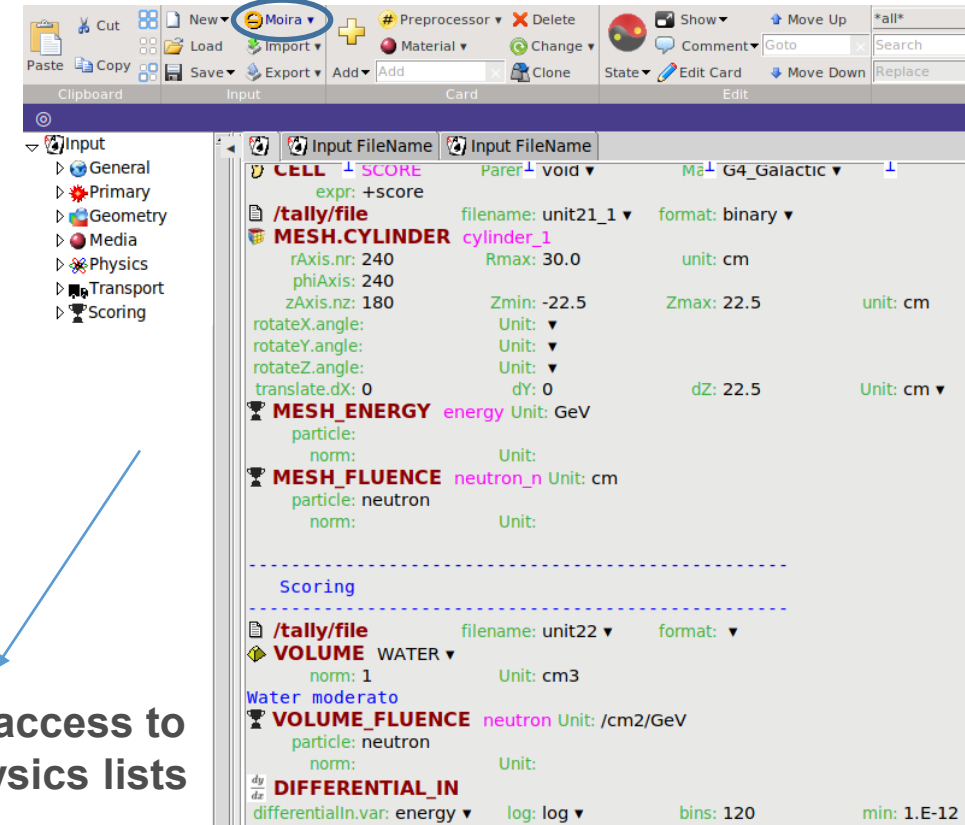

Reiterated final message

FLUKA entered a new youth, with a long term perspective and productive synergies with other codes.

The long due establishment of a formal Collaboration has opened fruitful opportunities to steer, accelerate, support and benefit from the FLUKA development.

