



Designing, building and running tracking detectors

Craig Sawyer

craig.sawyer@stfc.ac.uk

STFC Rutherford Appleton Laboratory

16th June 2026

Outline

- Introduction
- Tracking Detectors
- Silicon Detectors
- Layout
- Building a Detector
- The Reality
- The Future

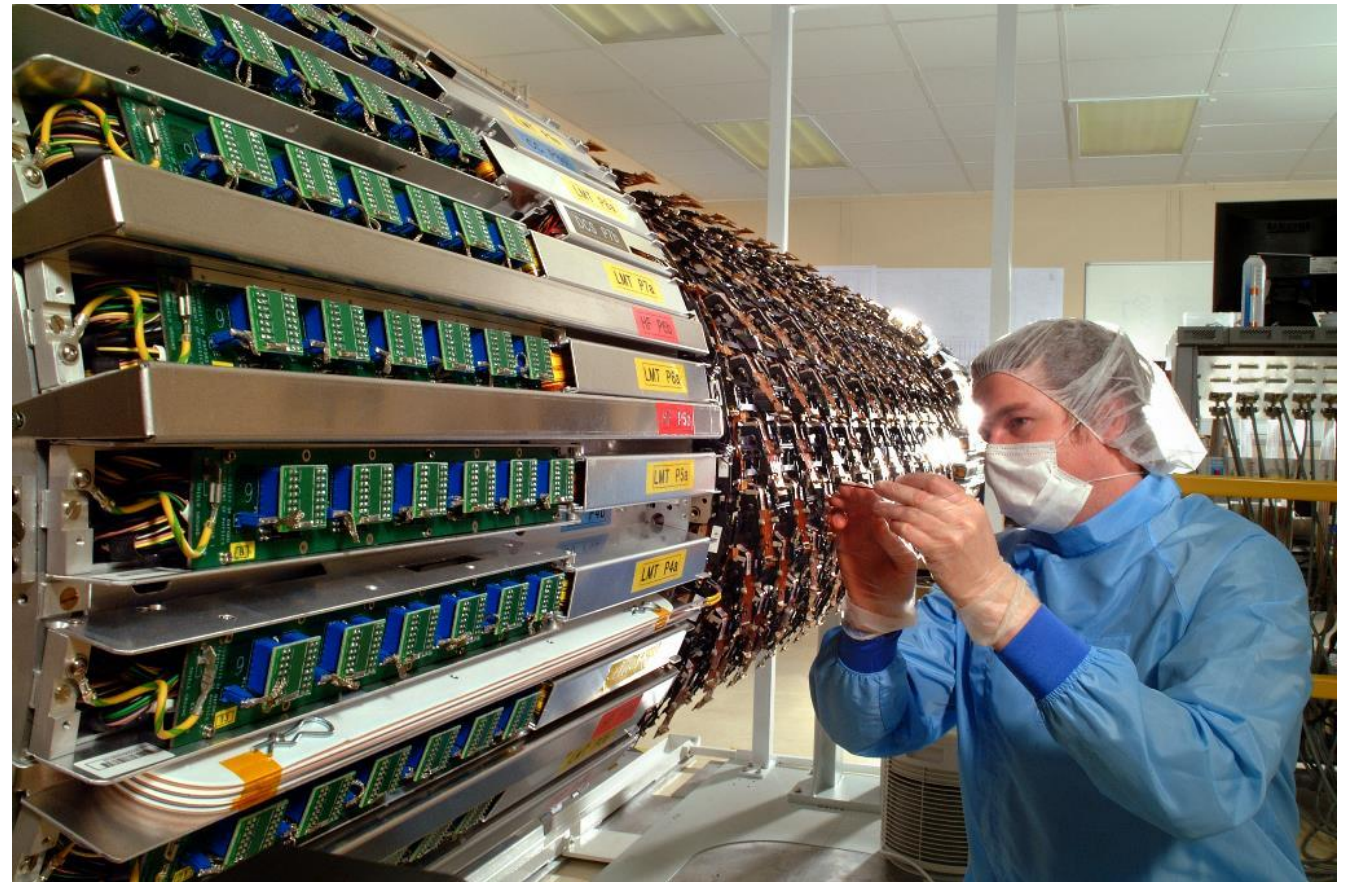

Introduction

- As you will come to realise, I am a physicist working on ATLAS ITk strips
 - Most of my examples are from ATLAS and the discussion is LHC-centric
- Have tried to concentrate on generalities of detector design
 - Dependent on exact use case, design priorities will change
 - Generally all tracking detectors aim for the same thing!
- Tried to think of the things that I wish I had been told/realised during my PhD days
- I assume everyone will have seen lectures on silicon detectors before but will anyway start with the basics

- ***Please feel free to stop me and ask questions at any point!!***



PART 1: TRACKING DETECTORS

Particle Tracking

- Particle tracking ubiquitous in particle physics from bubble chambers in the 1950s to large area tracking detectors at the LHC today

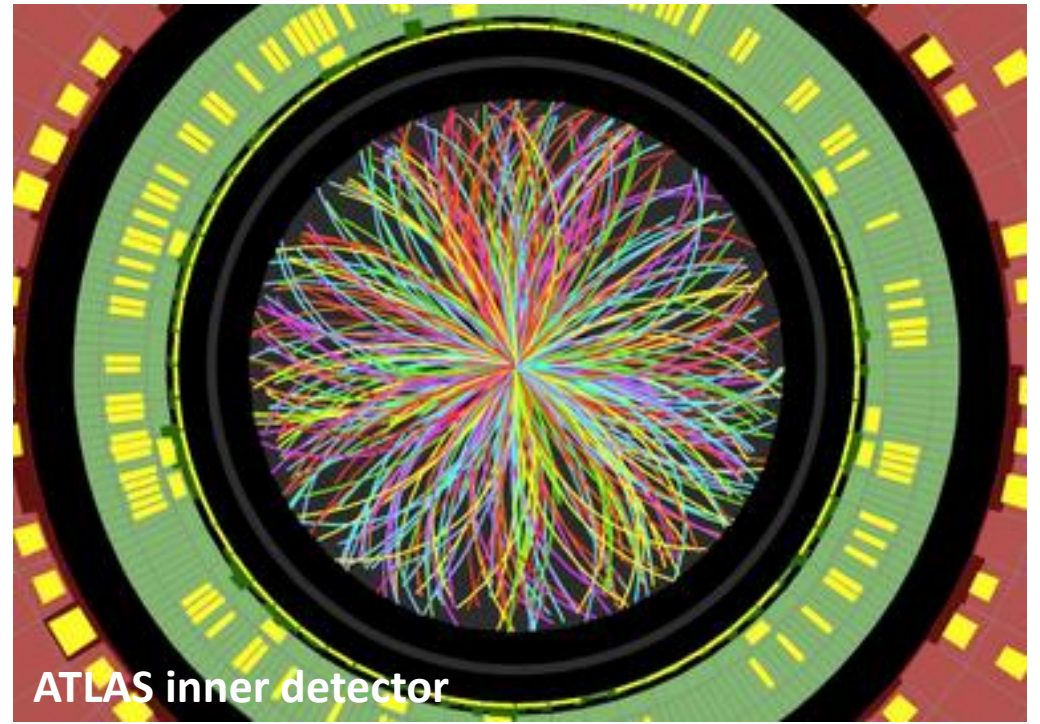
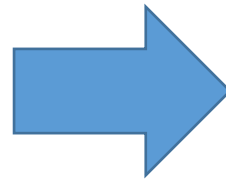

Particle Tracking

- Particle tracking ubiquitous in particle physics from bubble chambers in the 1950s to large area tracking detectors at the LHC today

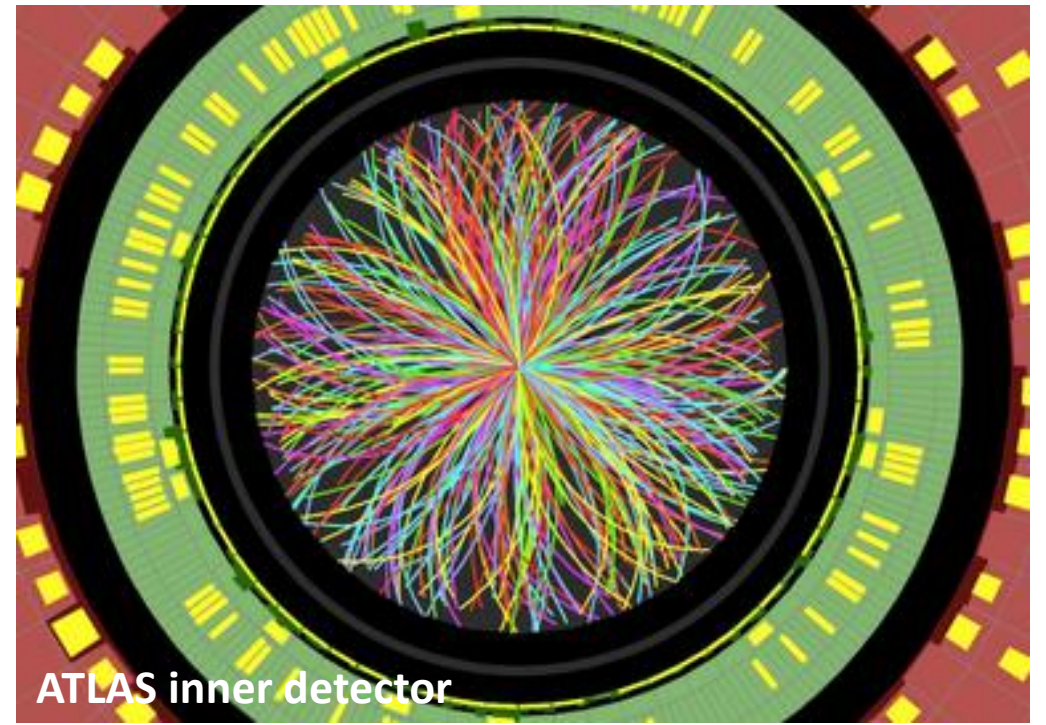
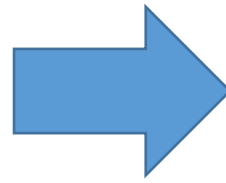
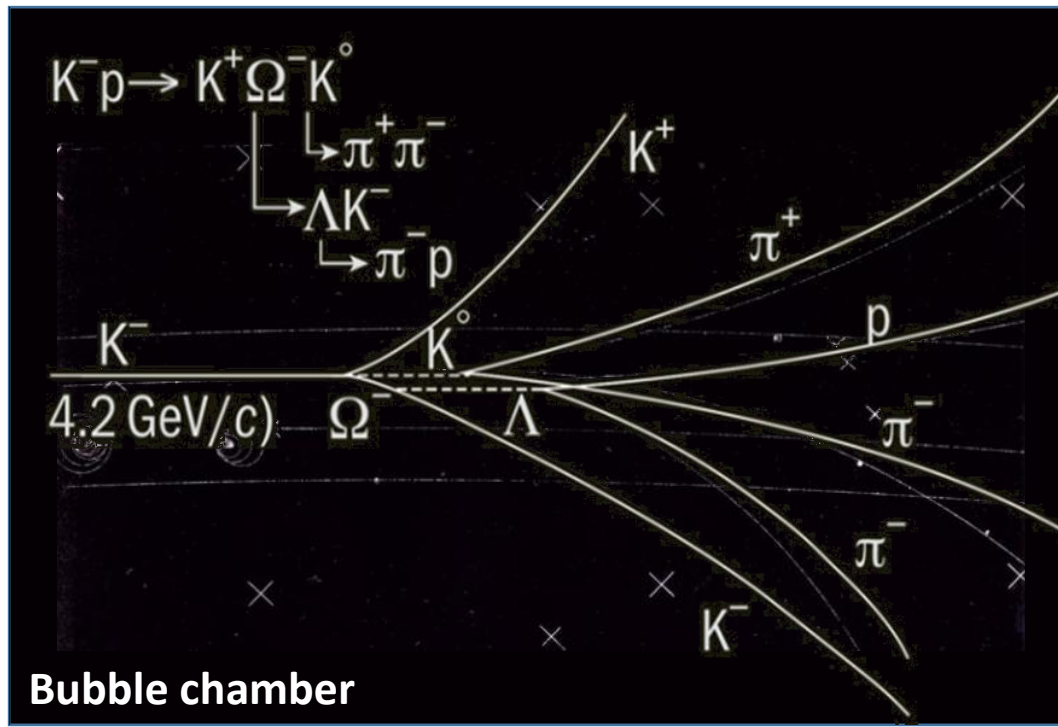

Particle Tracking

- Particle tracking ubiquitous in particle physics from bubble chambers in the 1950s to large area tracking detectors at the LHC today

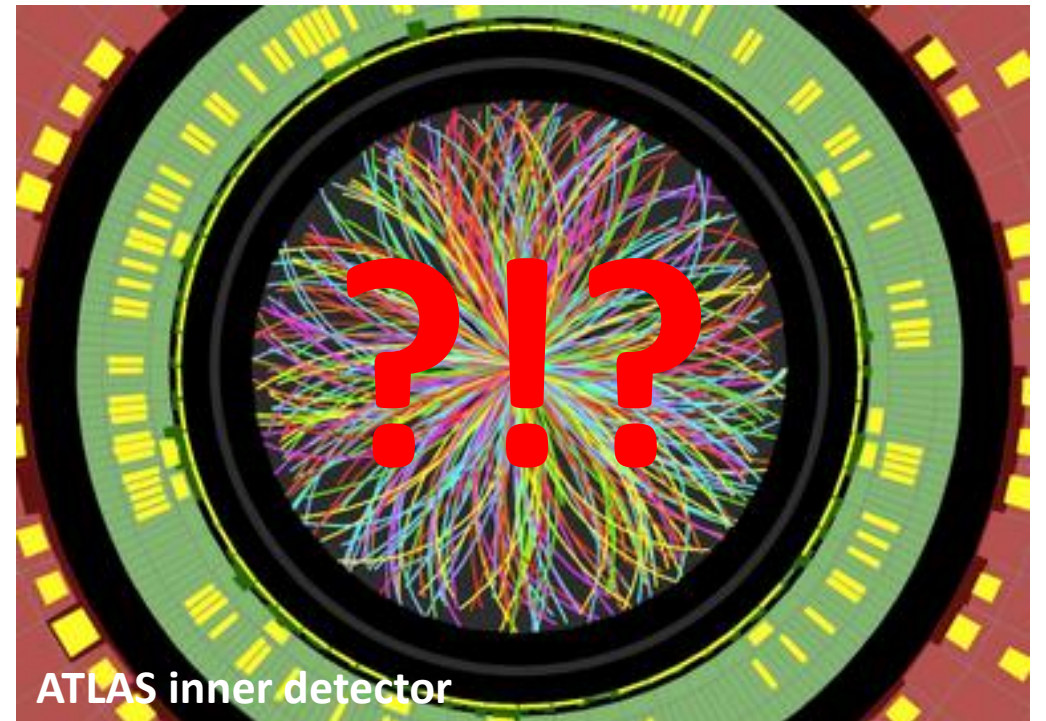
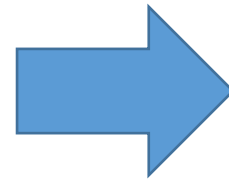
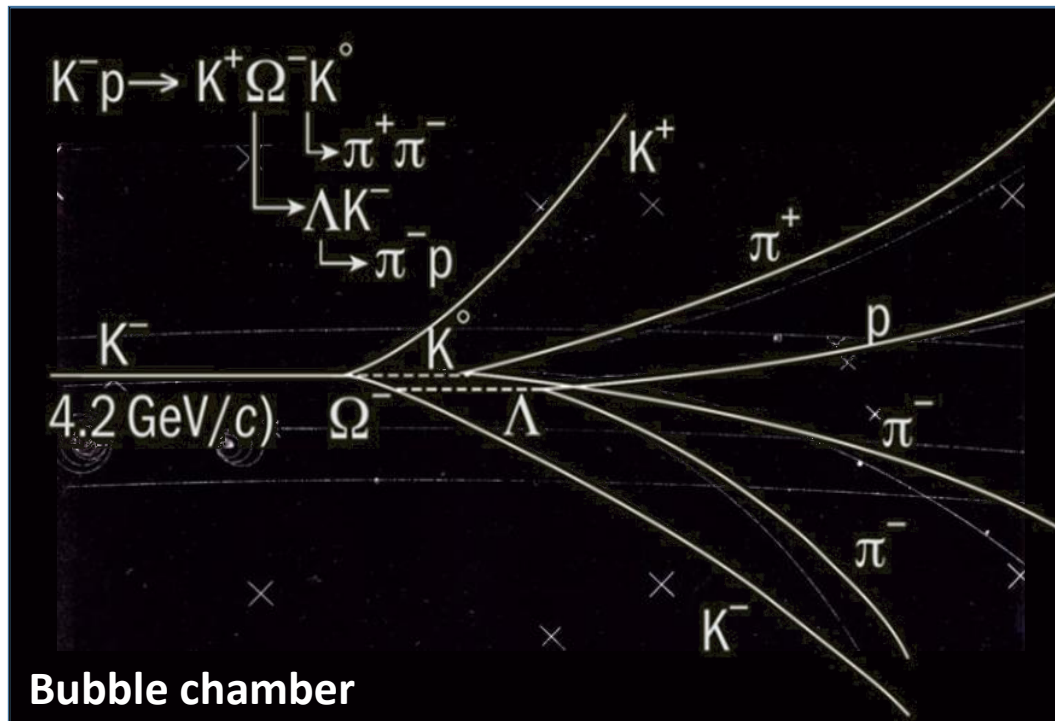

Why track particles?

- Particle tracking allows the reconstruction of the motion of charged particles in a magnetic field
- Measurement of
 - Electric charge (direction of bend)
 - Transverse momentum (extent of bend)
 - Direction
 - dE/dx (energy loss per distance)
- Reconstruction of
 - Primary and secondary vertices
 - Impact parameters
 - Identification of τ , b etc.
 - Calorimeter impact point

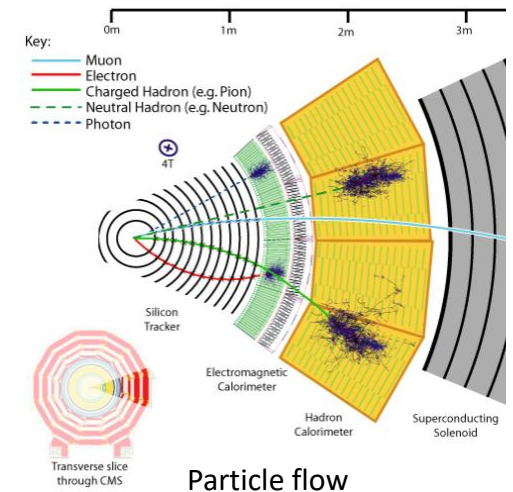
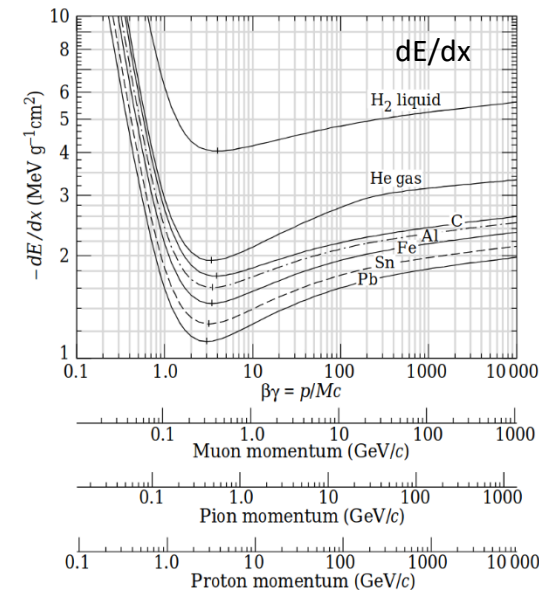
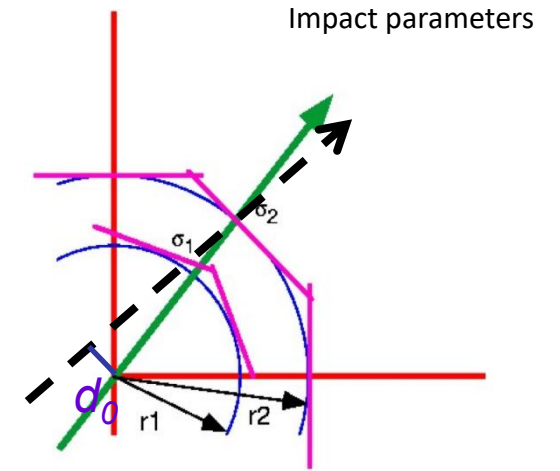
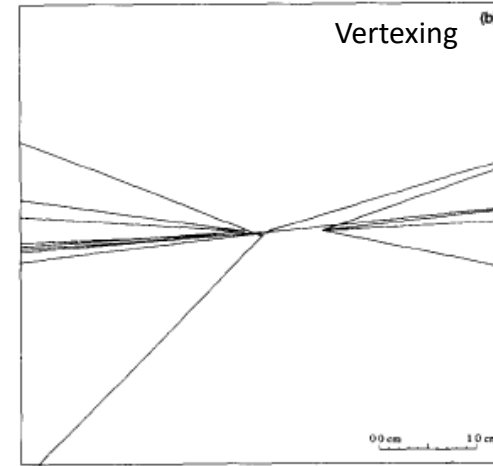

Tracking detector requirements

- High granularity
- High data rates
- Fast response
- Low material
- High stability
- Low noise
- Low power
- Radiation tolerant
- Simple
- Cheap!!
- Easy to build
- Easy to maintain

The smaller the pixel size, the better the resolution:

$$\sigma^2 = \int_{-p/2}^{p/2} \frac{x^2}{p} dx = \frac{p^2}{12}$$

Fast collection time important at high rates (10s of ns)

-> Even faster response time (10s of ps) allows time-based separation of tracks for improved background rejection

Reducing material reduces multiple scattering

Lower noise means you can pick-up smaller signals

Low power means less copper needed to deliver power and less cooling required

Detector must satisfy requirements throughout lifetime



PART 2: SILICON DETECTORS

Silicon detectors

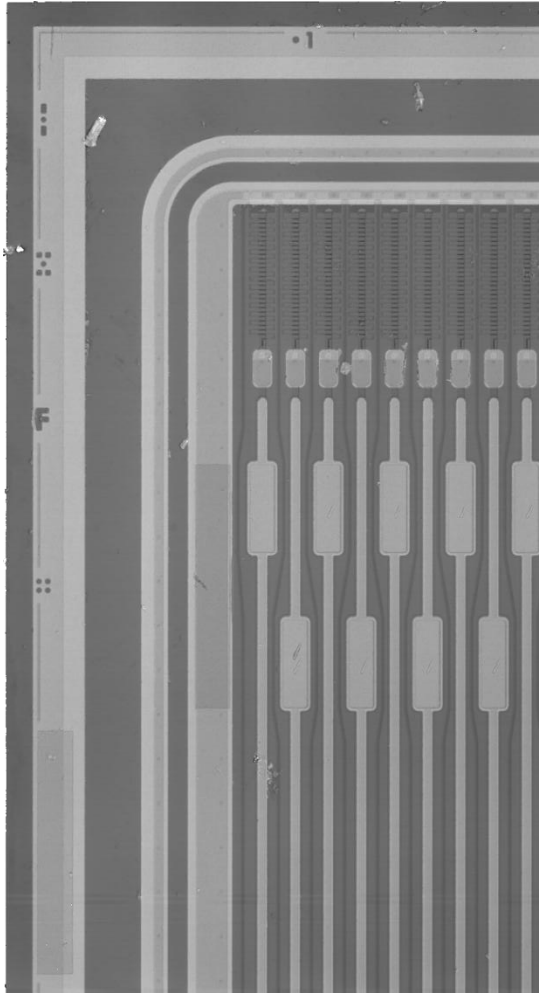

- Silicon detector is “just” a reverse biased diode
- Charged particle ionises depletion layer
- Ionisation products (electrons and holes) produce a signal
 - Often called the “collected charge” (CC)

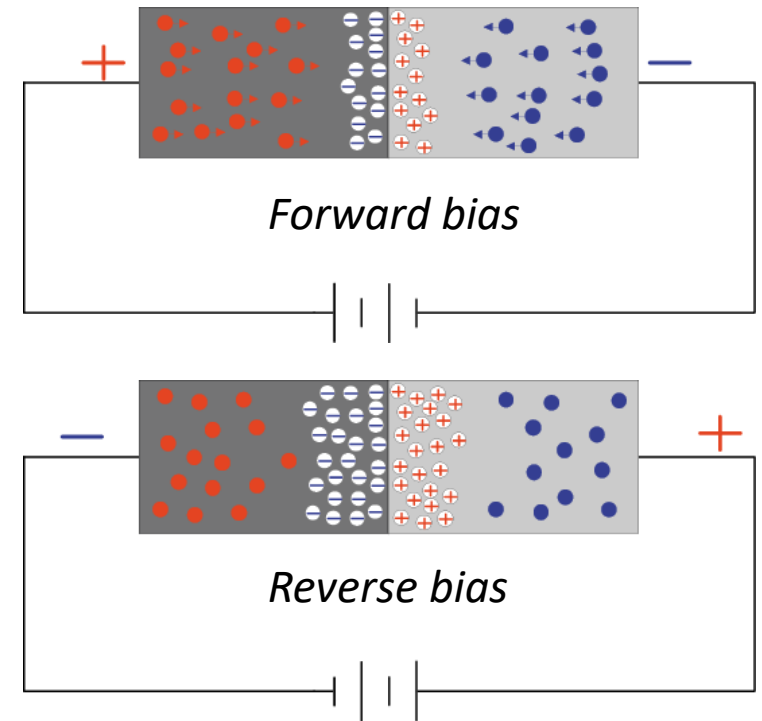
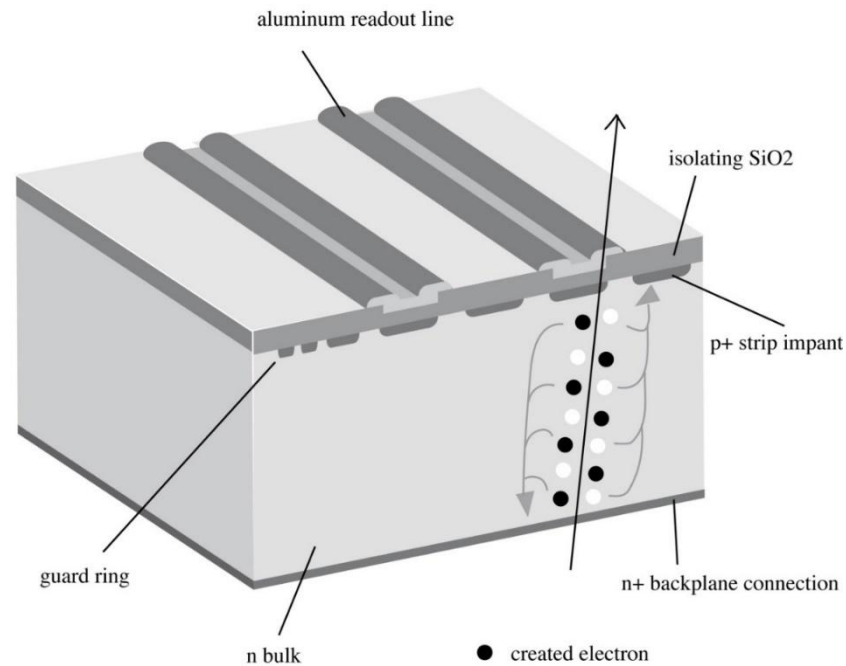

Strips or pixels?

- Diodes and collecting electrodes can be made “any shape you want”
- Typically two options are used:
 1. Approximately square sensor elements $O(100)\mu\text{m} \times O(100)\mu\text{m}$ – “PIXELS”
 2. Long, thin sensor elements $O(2)\text{cm} \times O(100)\mu\text{m}$ – “STRIPS”
- Each have their own advantages and disadvantages
- Pixels deployed at low radius, strips at high radius

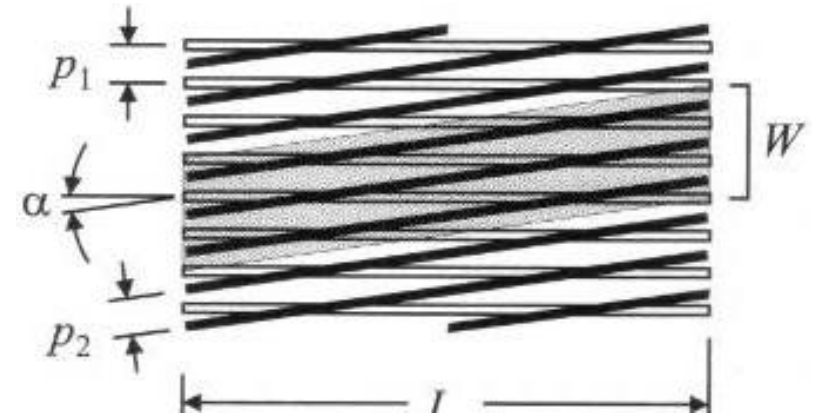

Pixels	Strips
High resolution in both directions	High resolution in only one direction*
High data rates required to readout	Lower data rates required to readout
Lower material budget (fewer layers per space point)	Higher material budget
High power density	Low power density
Expensive when covering large areas	Effective way of covering large areas of silicon

* silicon can be processed on both sides or sensors placed back-to-back

Silicon modules

- Need a way to take analogue signals from sensors and readout digitally
- Leads to the concept of the hybrid module
- ASICs designed to readout each detector
 - Typically multiple ASICs per detector due to complexity
- Combination of sensor, ASIC and any PCB circuitry referred to as a module
- Strip ASICs and sensors are connected together using wire-bonding
 - $25\mu\text{m}$ aluminium wire ultrasonically welded to aluminium pads on sensors and ASICs
- Due to increased channel density, ASIC-sensor connection in pixels must be done using bump bonding

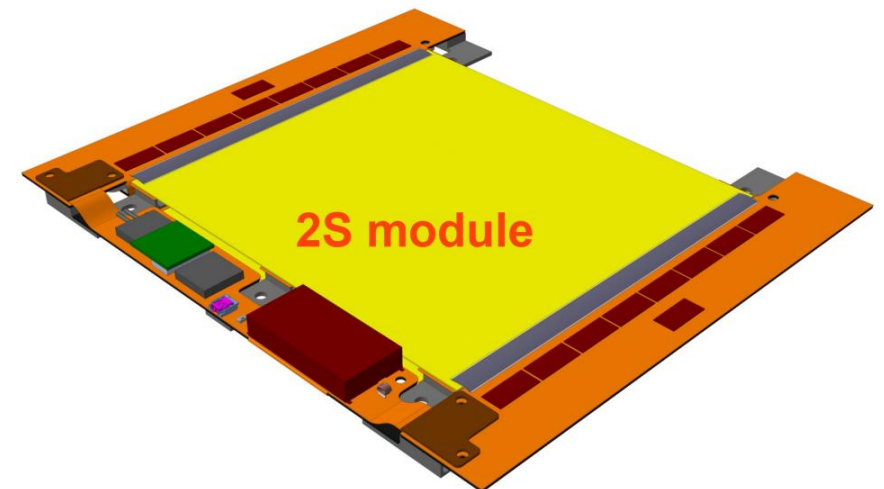
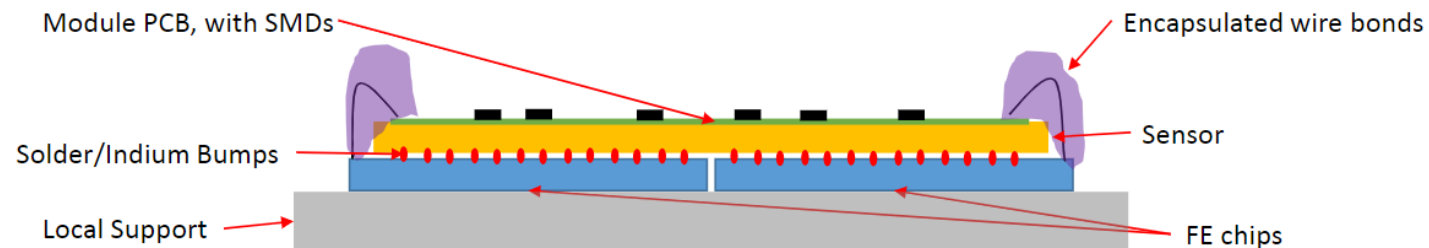
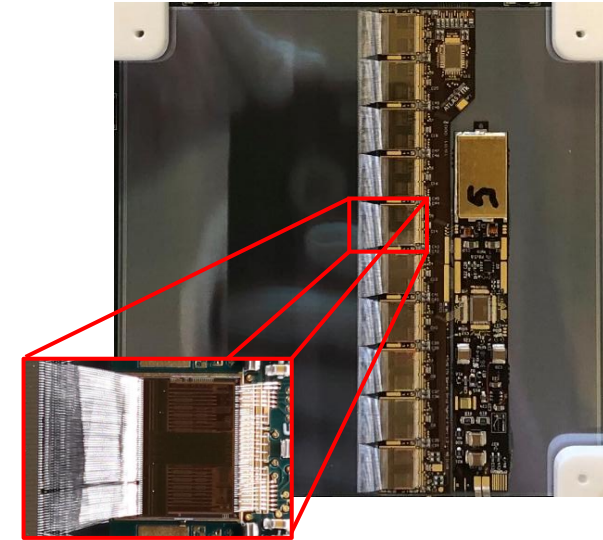

Something in between?

- At what point do strips and pixels meet?
- This is the CMS upgrade PS module
 - Strip detector on one side with 2.5cm strips
 - Macropixel sensor on other side with 1.5mm “macropixels”
- A true hybrid module!!

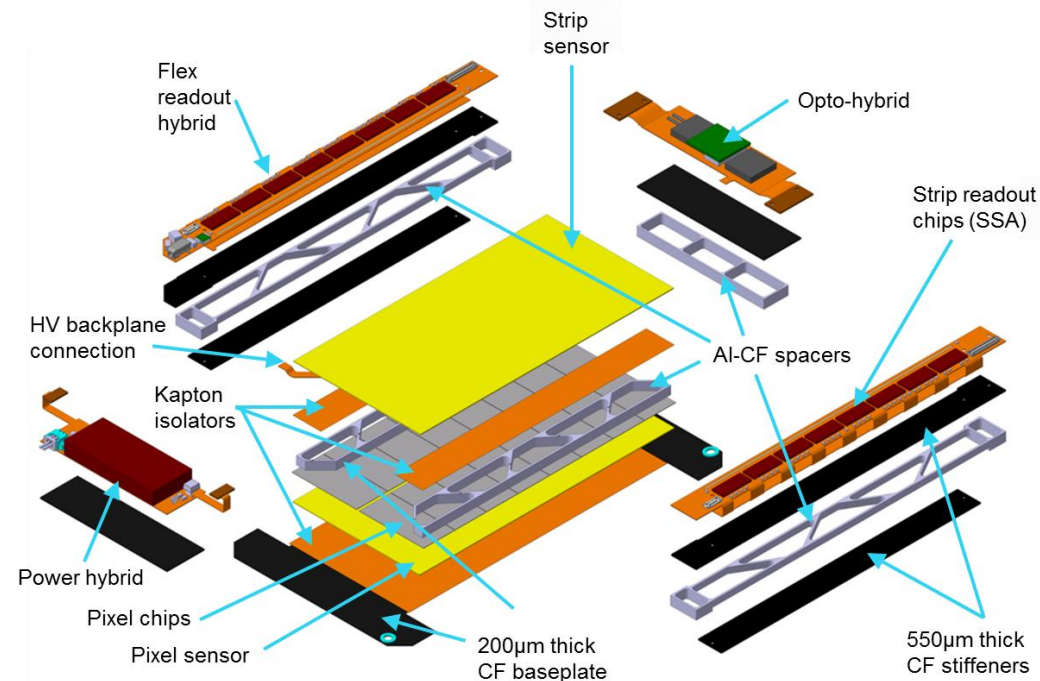
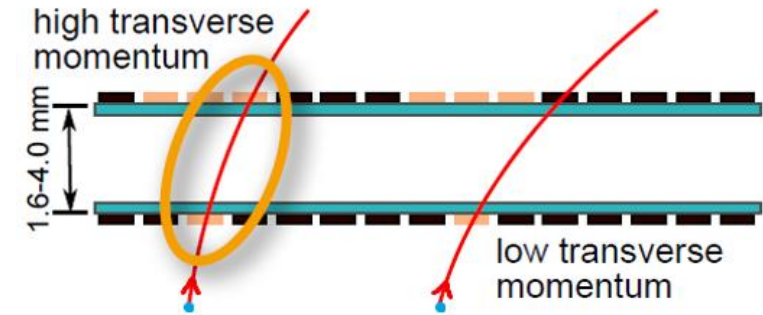

Signal and noise in silicon

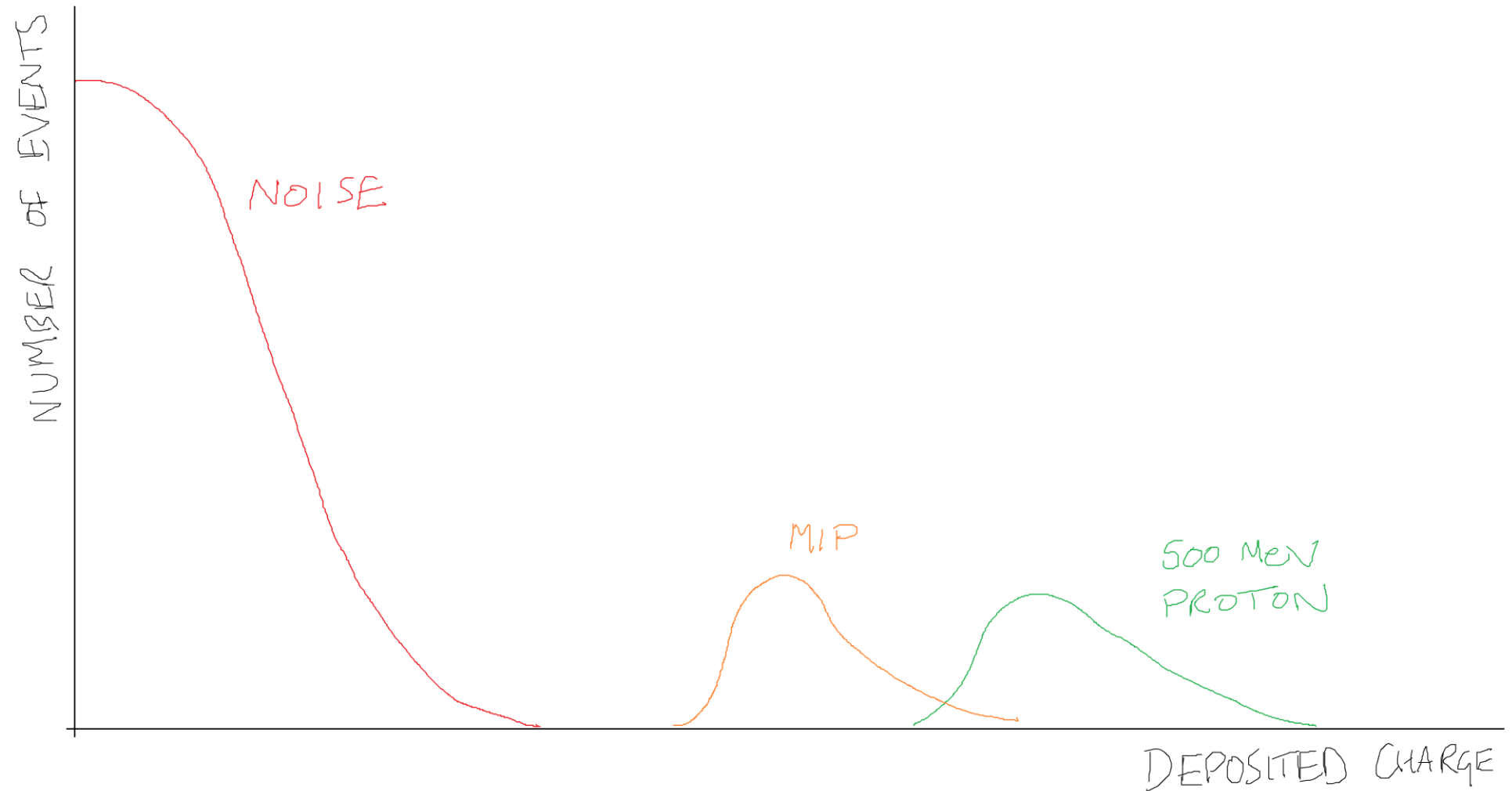

Signal and noise in silicon

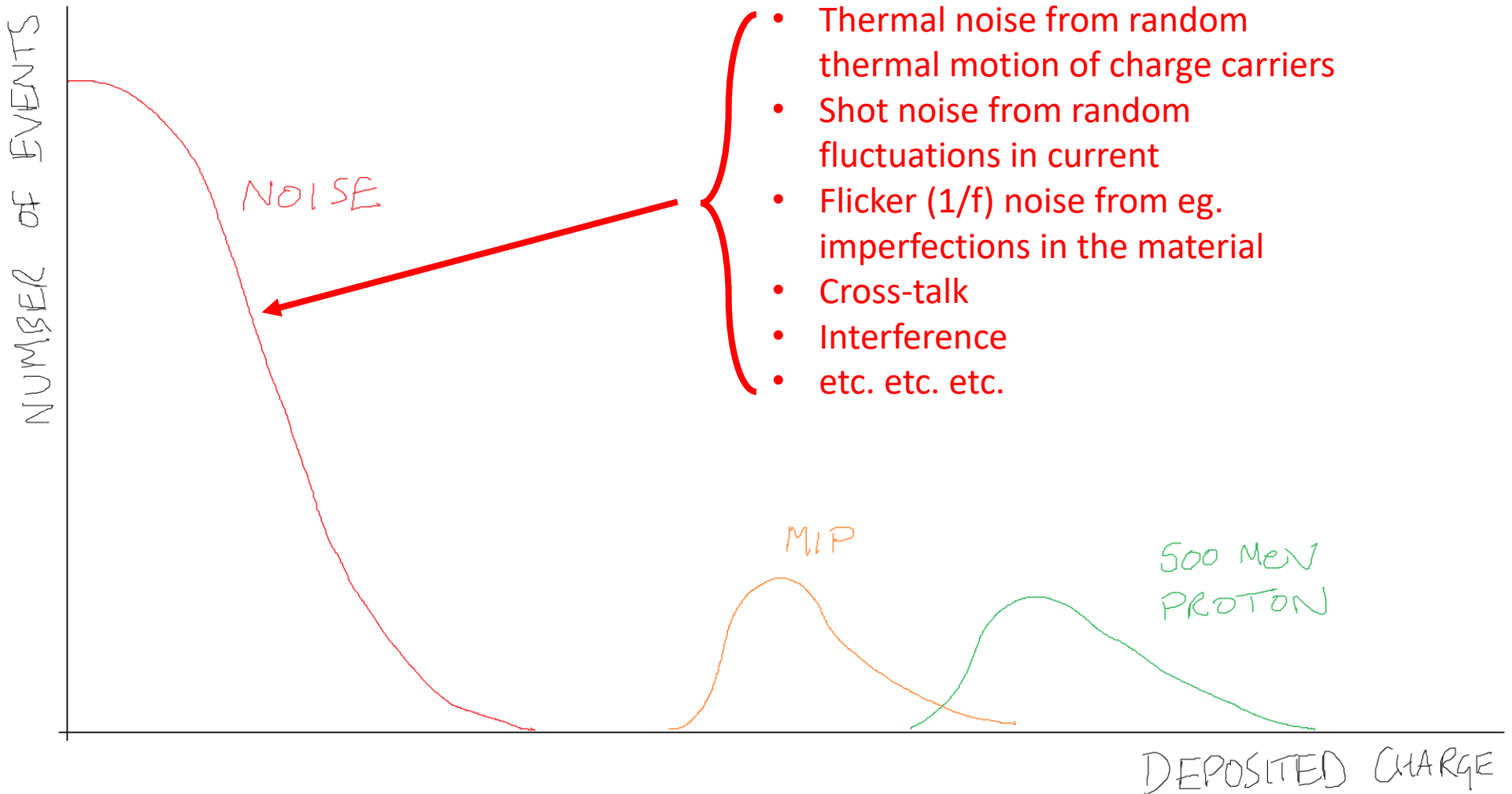

Signal and noise in silicon

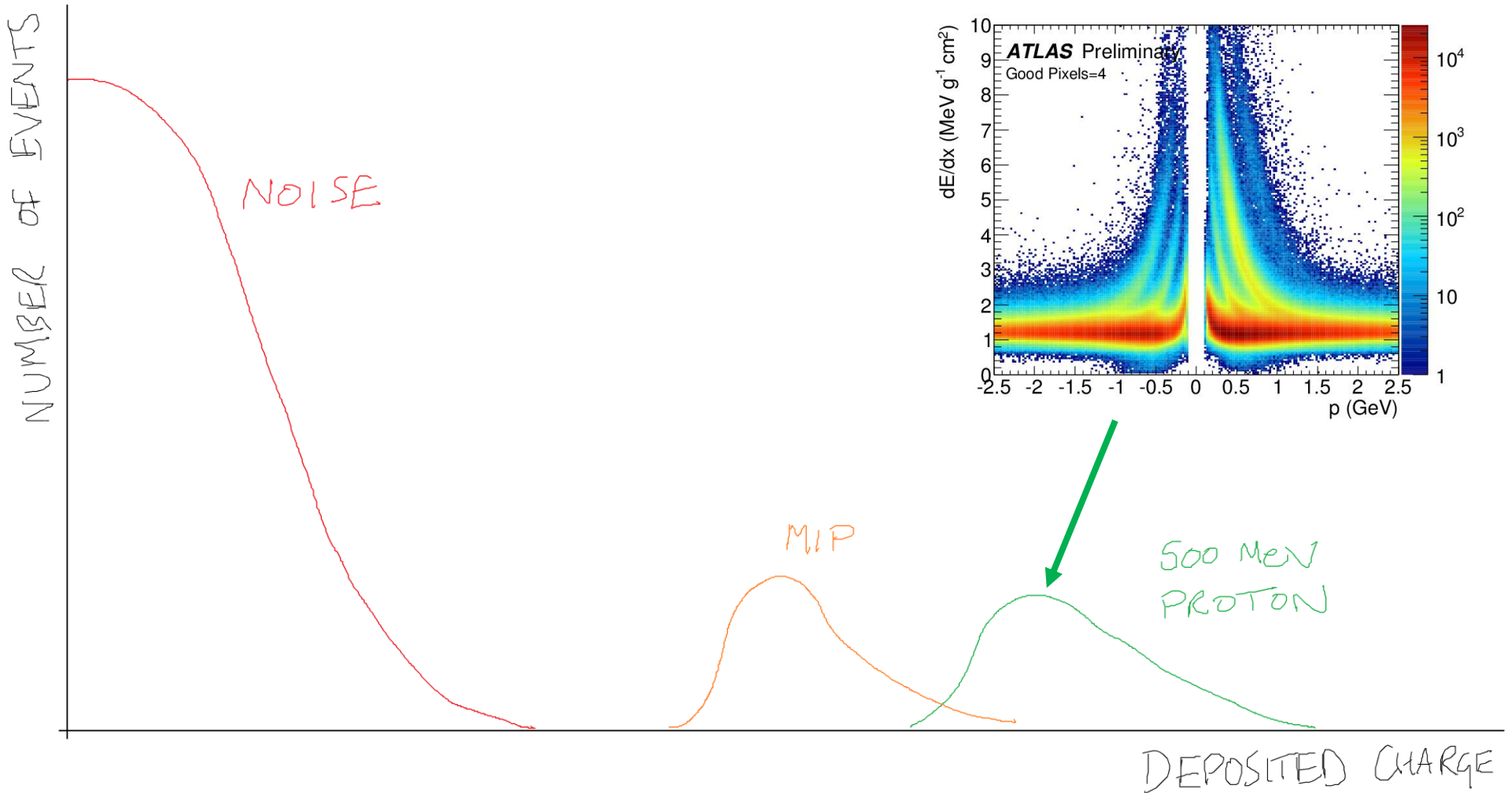

Signal and noise in silicon

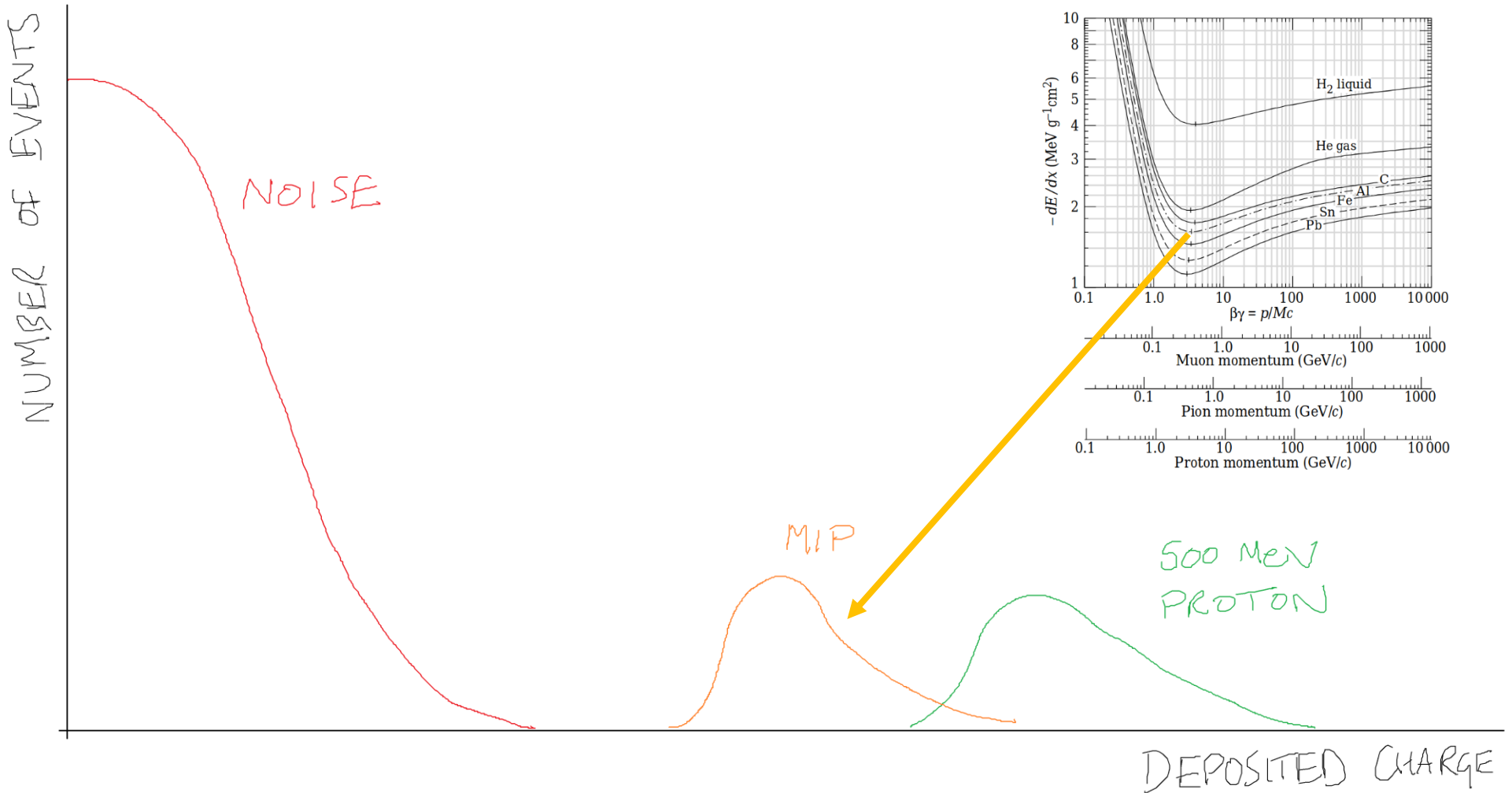

Binary readout

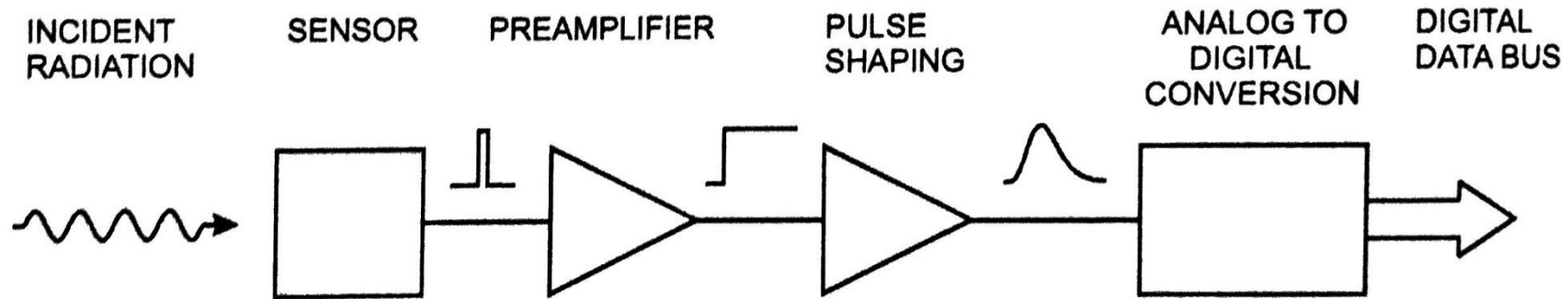

- Typically do not readout the analogue pulse shape
- Instead read out digitally
 - Above “analog to digital conversion” just a simple comparator to a threshold voltage
 - Only information leaving the detector is a hit (1) or lack of hit (0)
 - Was there a pulse above the set threshold?
 - Sometimes can include timestamp or time over threshold (ToT) value

Thresholds

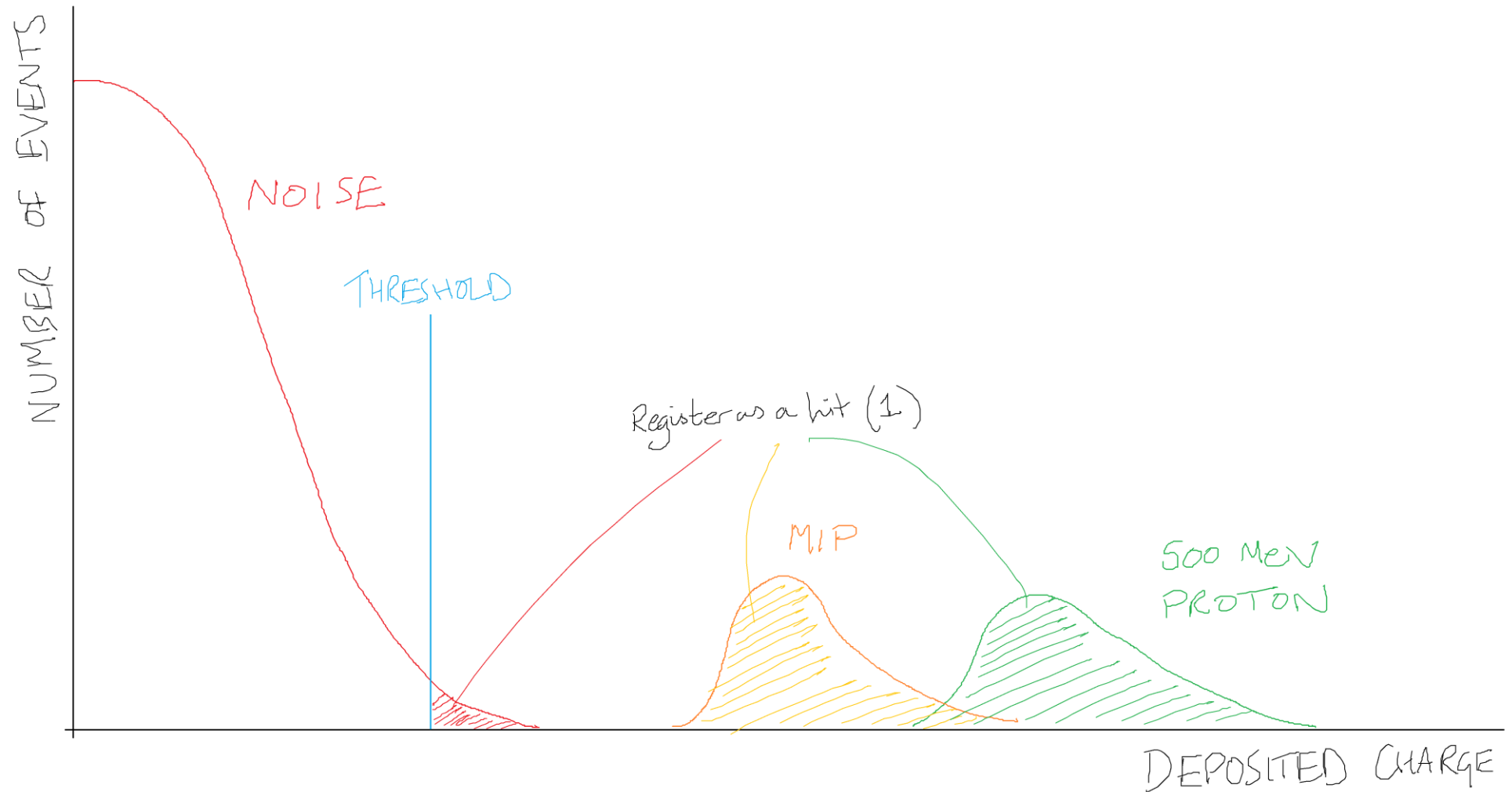

Threshold scans

- In order to understand the behaviour of the detector can perform threshold scans
 - Measure the occupancy as a function of threshold
- This can be done in three cases:
 - No injected charge (“noise occupancy”)
 - Injecting a calibration charge generated within the readout ASIC
 - Injecting charge into the sensor using photons or ionising particles

$$\text{Occupancy} = \int_{\text{threshold}}^{\infty} N_{\text{event}} dx$$

A threshold scan

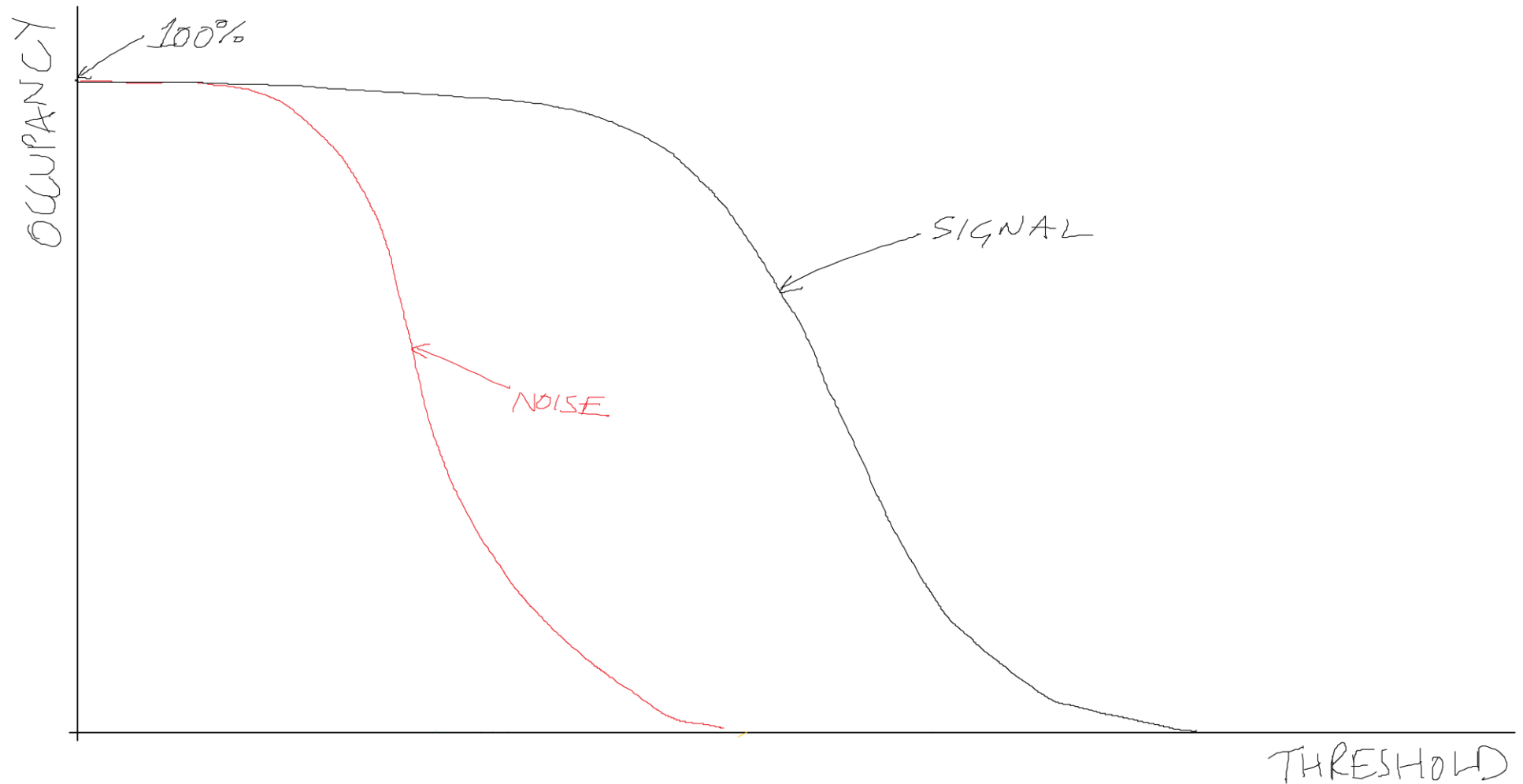

A threshold scan

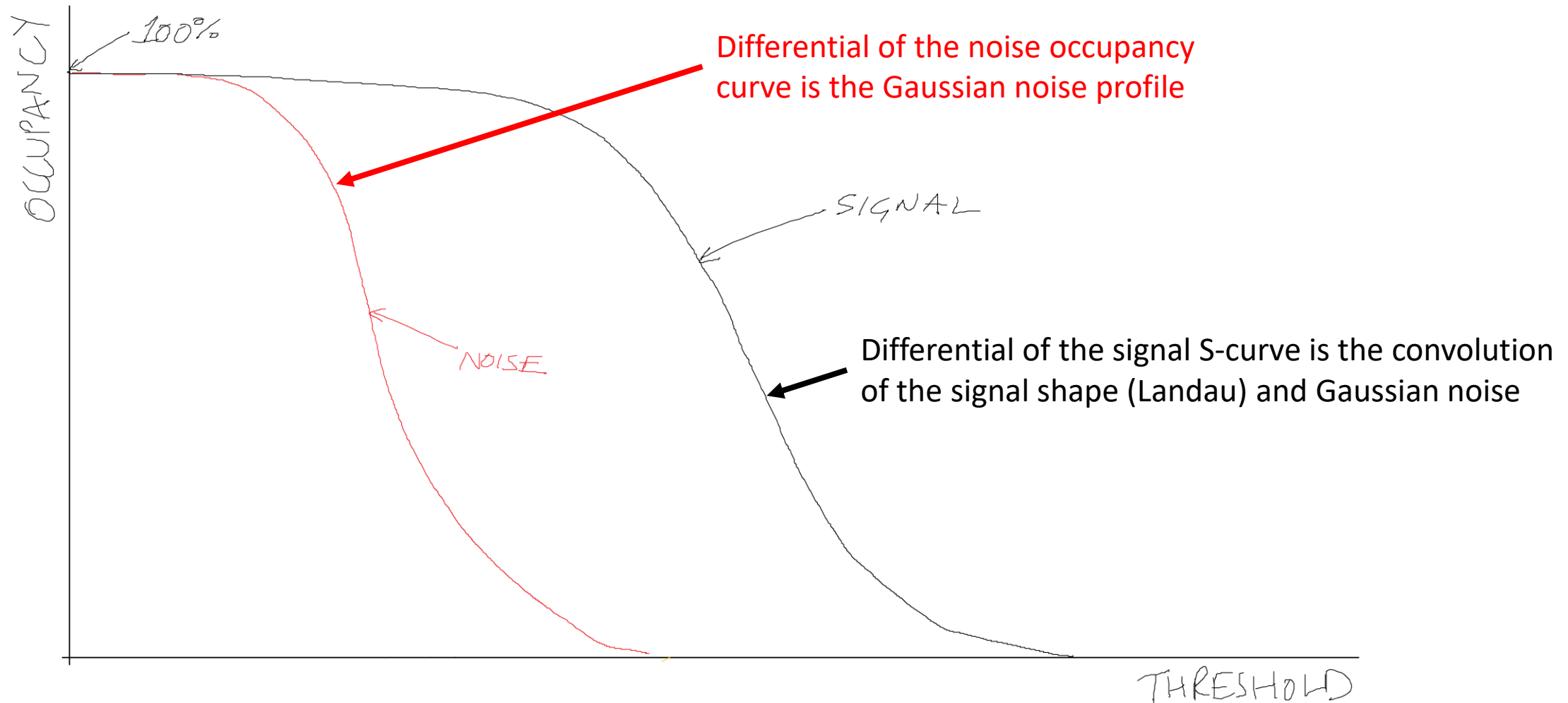

Radiation damage

- Radiation damage can affect both sensors and readout electronics
- Bulk damage from Non Ionizing Energy Loss (NIEL)
 - Change of effective doping concentration ($\uparrow V_{dep}$)
 - Increase of leakage current (\uparrow noise)
 - Increase of charge carrier trapping (\downarrow CC)
- Surface damage due to Total Ionising Dose (TID)
 - Charge build-up in oxide or Si/oxide interface ($\uparrow C_{interstrip}$)
 - Charge build up in transistors in readout chips (\uparrow noise, \uparrow current, change in tuning)

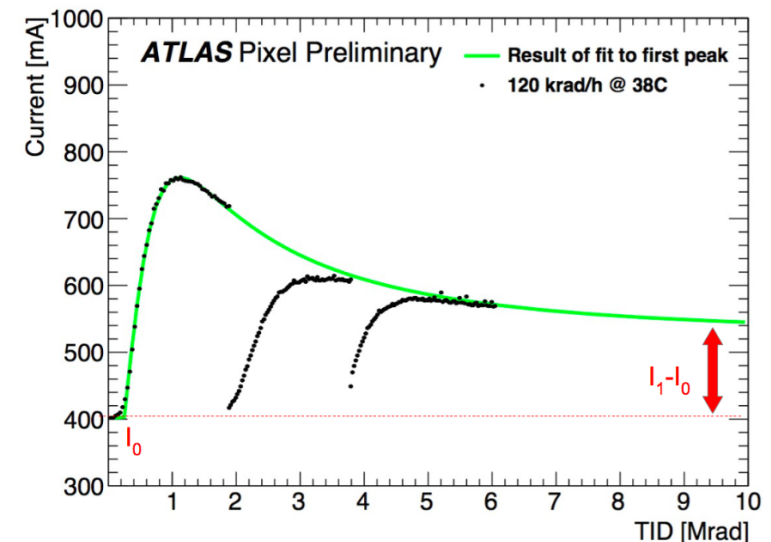
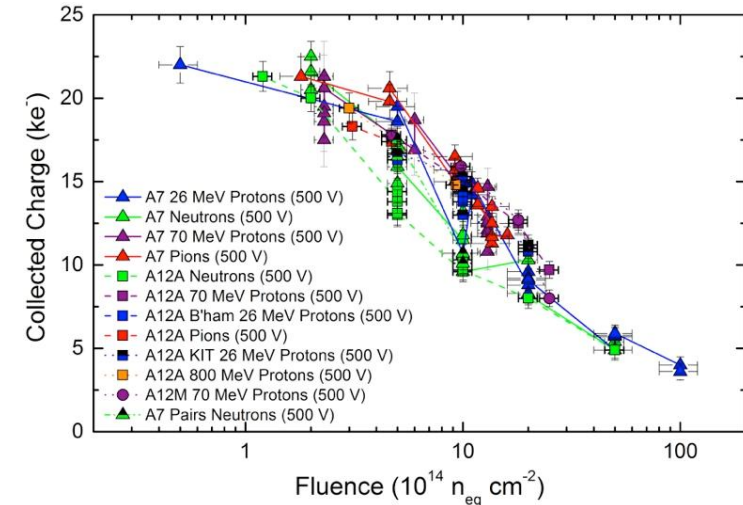

Radiation effects

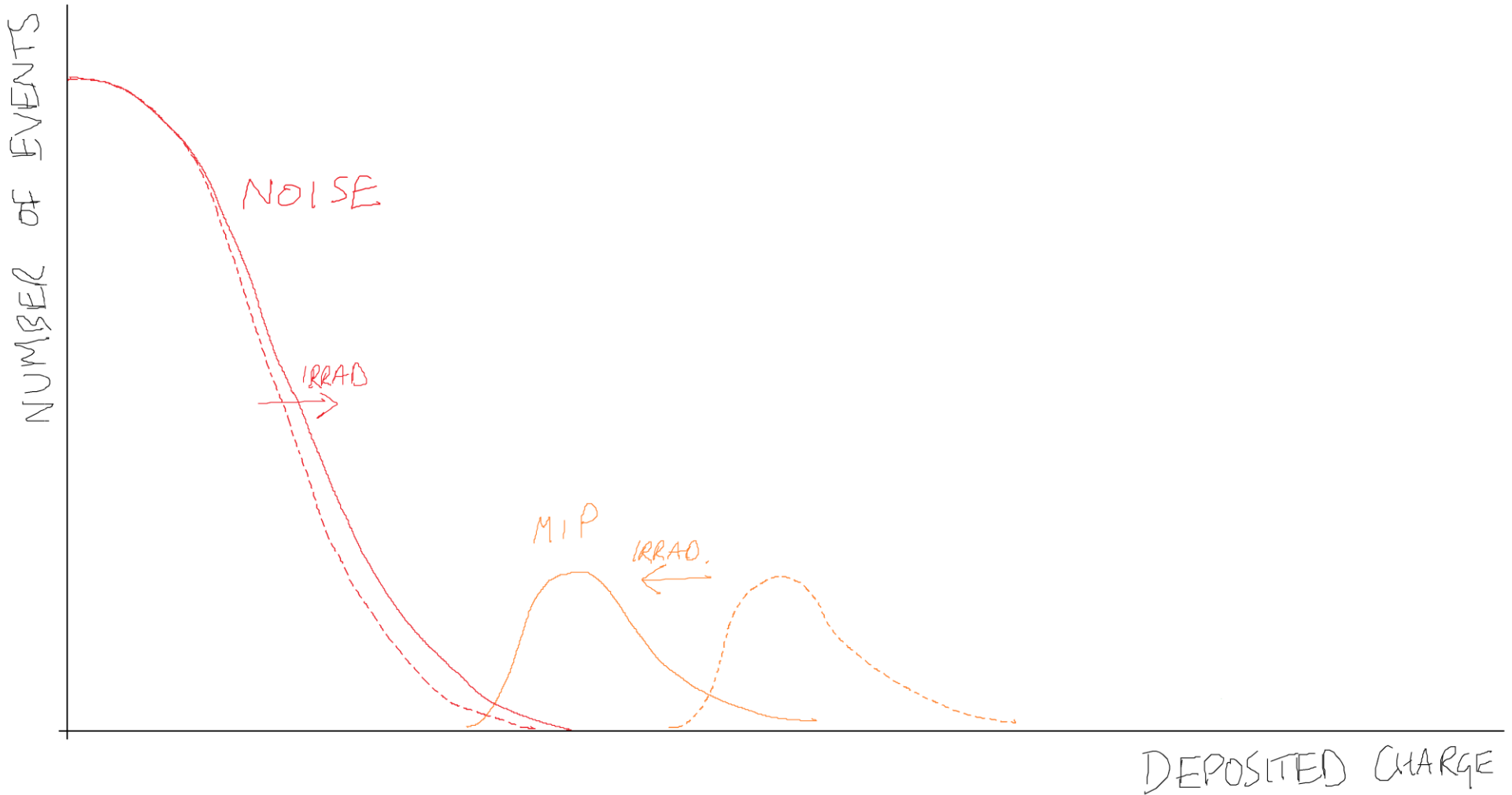

Radiation effects

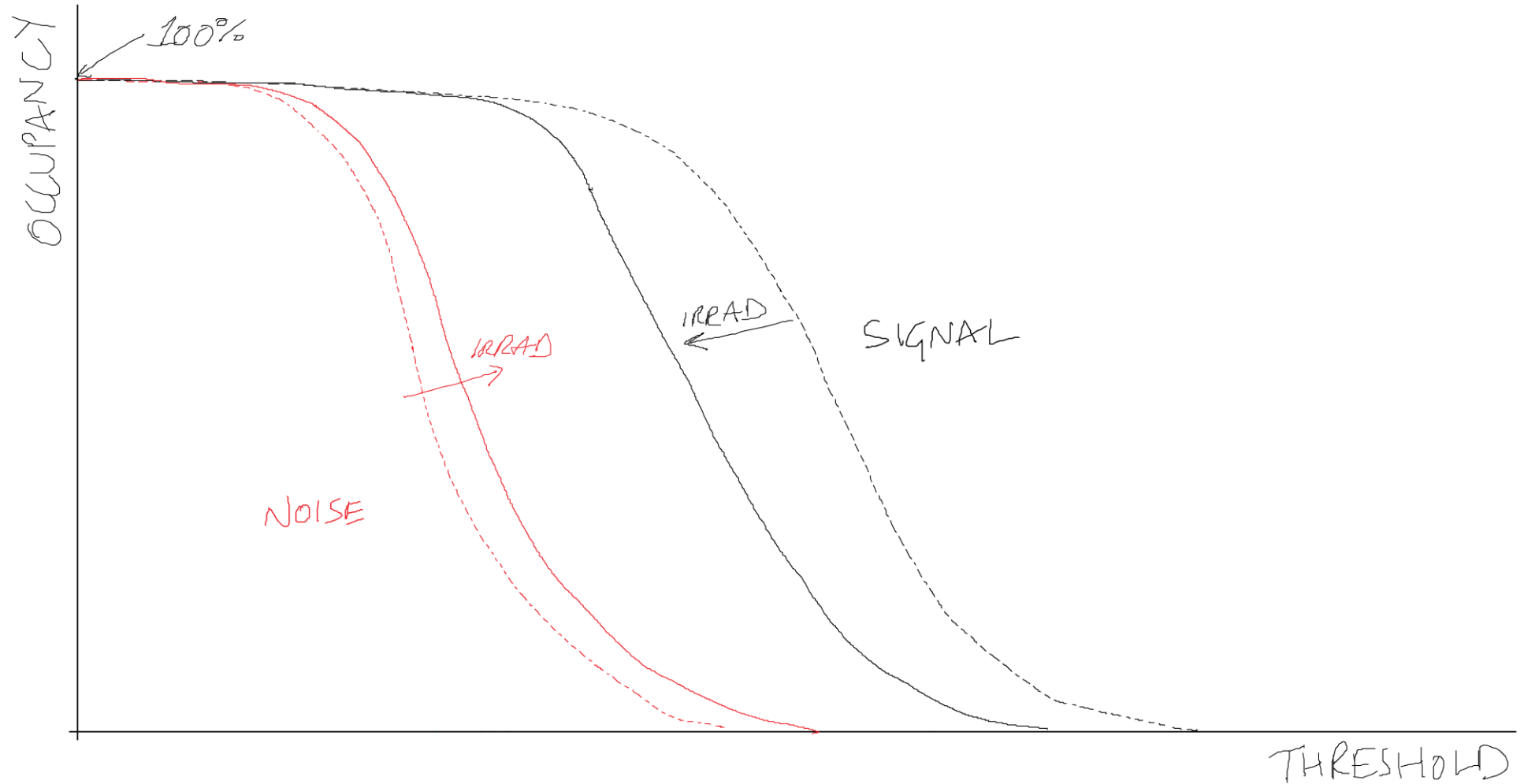

How to set the threshold

- Detector performance requirements derived from physics simulation (efficiency) and system considerations (noise)
 - Efficiency must be high enough to allow reconstruction of tracks
 - Noise must be low enough to not saturate the readout of the detector
 - Noise must be low enough to not explode the track reconstruction time
- For example, ATLAS ITk strips targets
 - Efficiency $\geq 99\%$
 - Noise occupancy $\leq 10^{-3}$
 - Approximately maps to S:N $\geq 10:1$

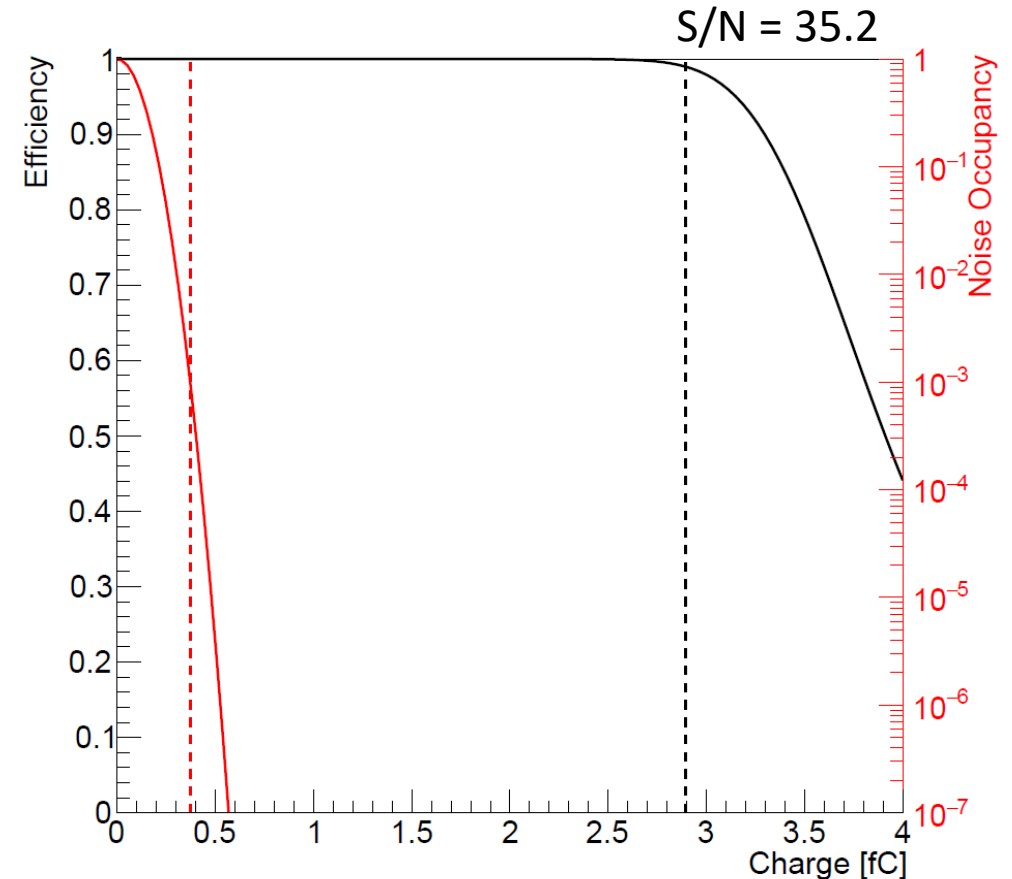

How to set the threshold

- Detector performance requirements derived from physics simulation (efficiency) and system considerations (noise)
 - Efficiency must be high enough to allow reconstruction of tracks
 - Noise must be low enough to not saturate the readout of the detector
 - Noise must be low enough to not explode the track reconstruction time
- For example, ATLAS ITk strips targets
 - Efficiency $\geq 99\%$
 - Noise occupancy $\leq 10^{-3}$
 - Approximately maps to S:N $\geq 10:1$

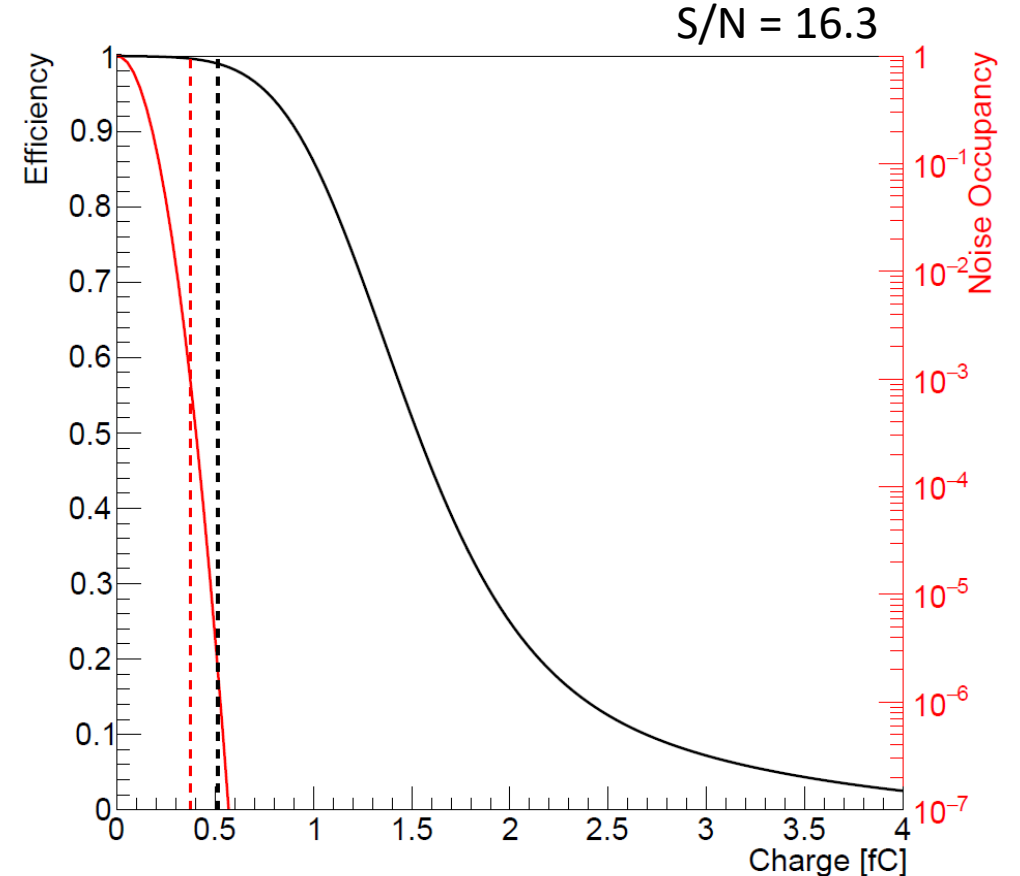

Calibrating the detector

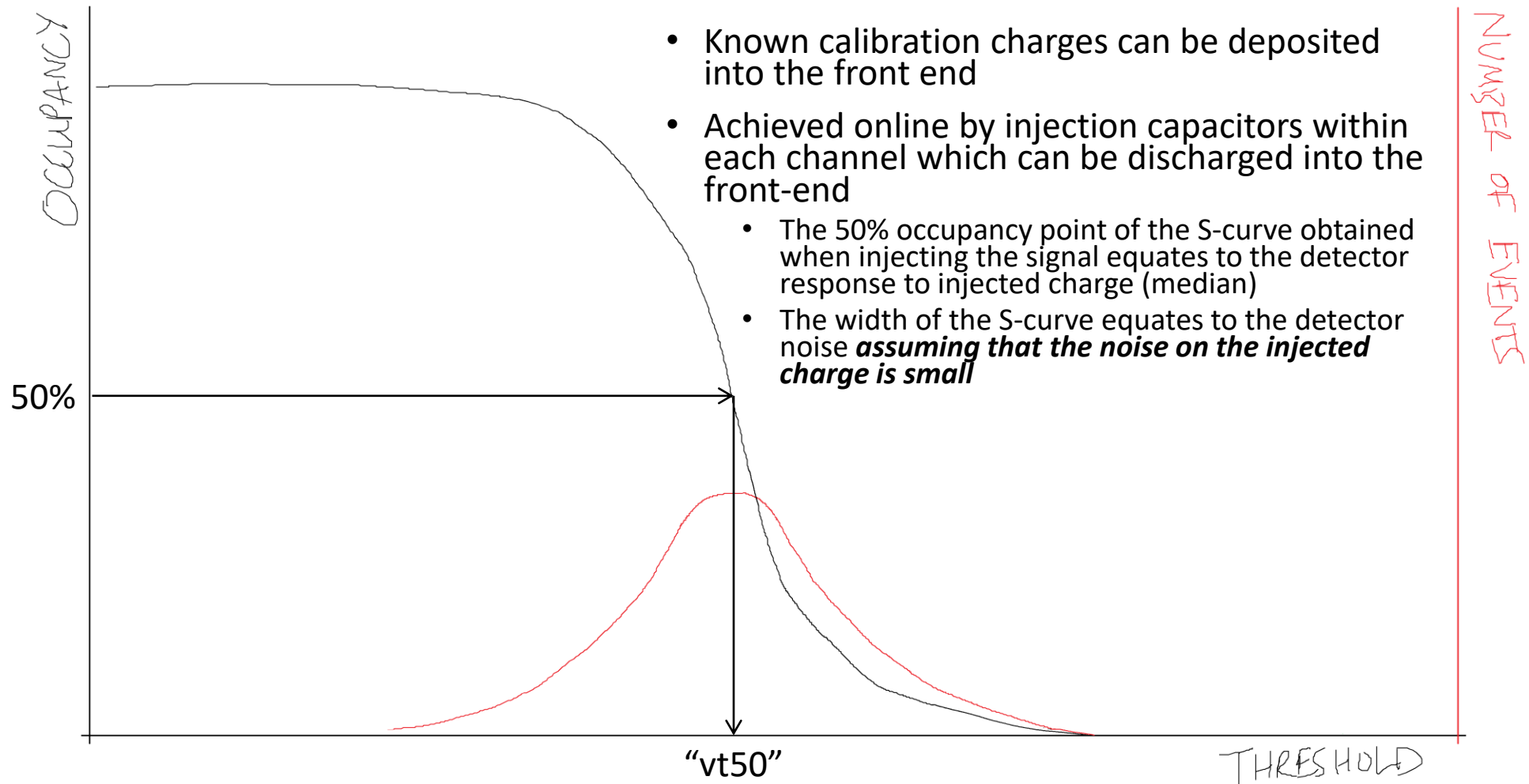

Calibrating the detector

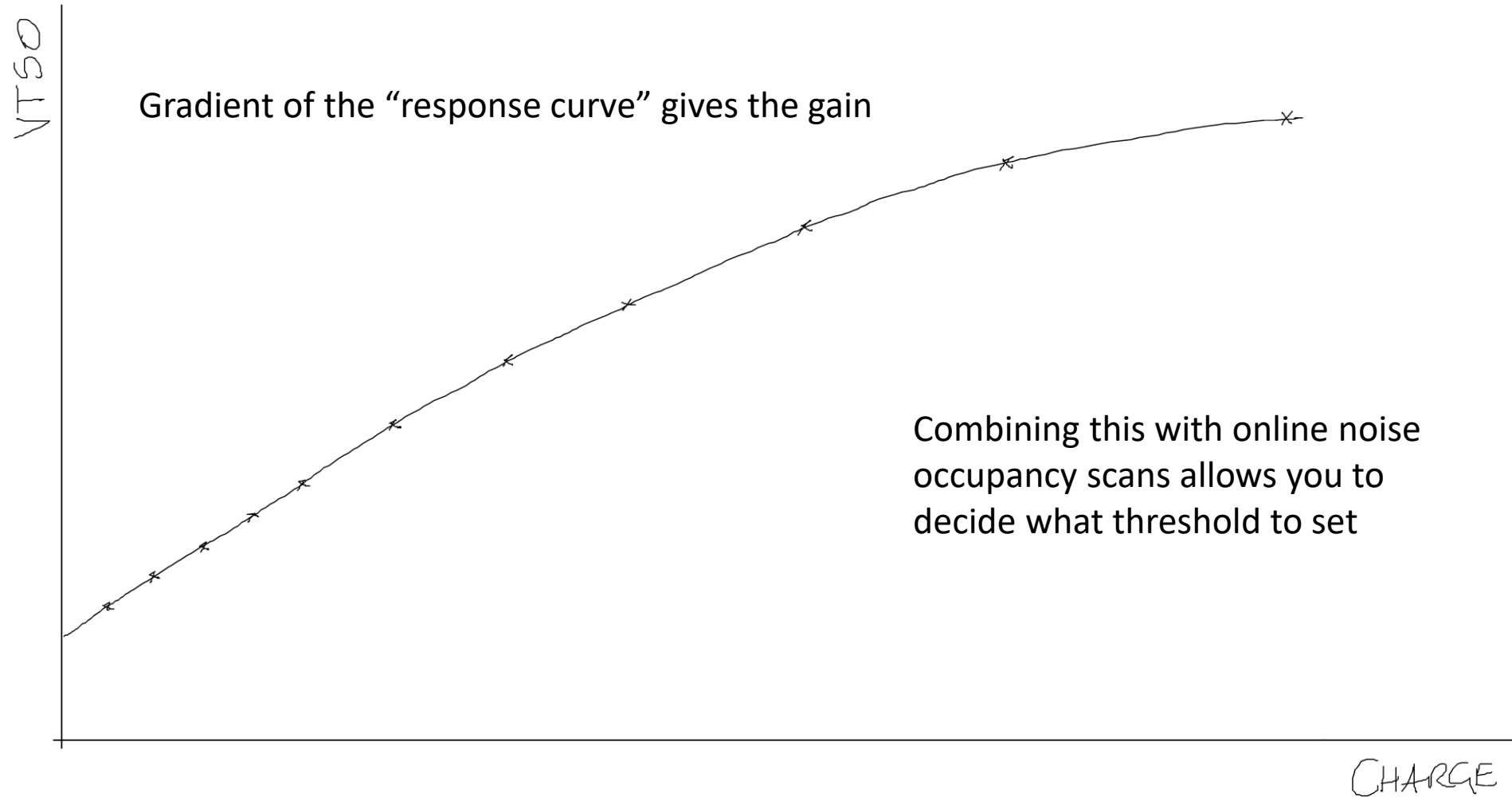

Timing

- Importance of timing varies strongly on the detector and environment
 - Unambiguous association of a track to a given bunch crossing (25ns)
 - ≤ 30 ps can allow resolution of vertices in time enough to separate primary and secondary vertices
 - About 9mm at the speed of light
- Note that really high speed requires more “exotic” technologies such as Low Gain Avalanche Detectors (LGADs) not discussed here
- Other time-related information can be extracted:
 - Time over threshold (ToT) to measure deposited charge
 - Time stamping to measure Time of Flight (ToF)

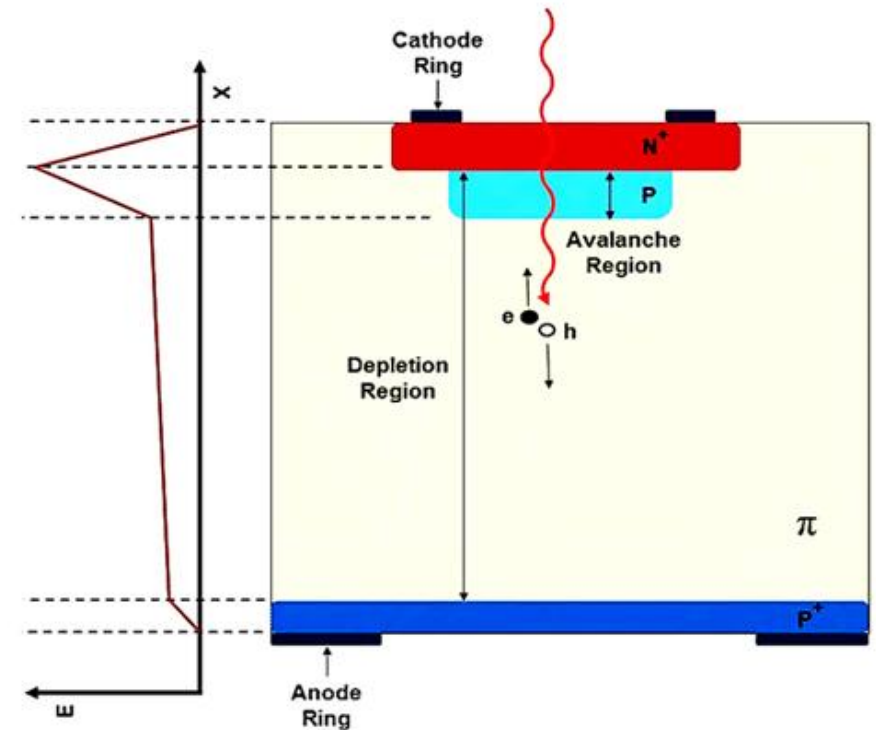

Timing

VOLTAGE AT COMPARATOR

Time over threshold (ToT) and/or timestamping can add useful extra information to a hit

Timewalk must be small enough to prevent timing ambiguities eg. ATLAS ITk strips require ≤ 16 ns timewalk between 0.75 fC and 10 fC signals with a threshold of 0.5 fC

To remove effects of timewalk on timestamps a second (lower) threshold can be used to generate the timestamp

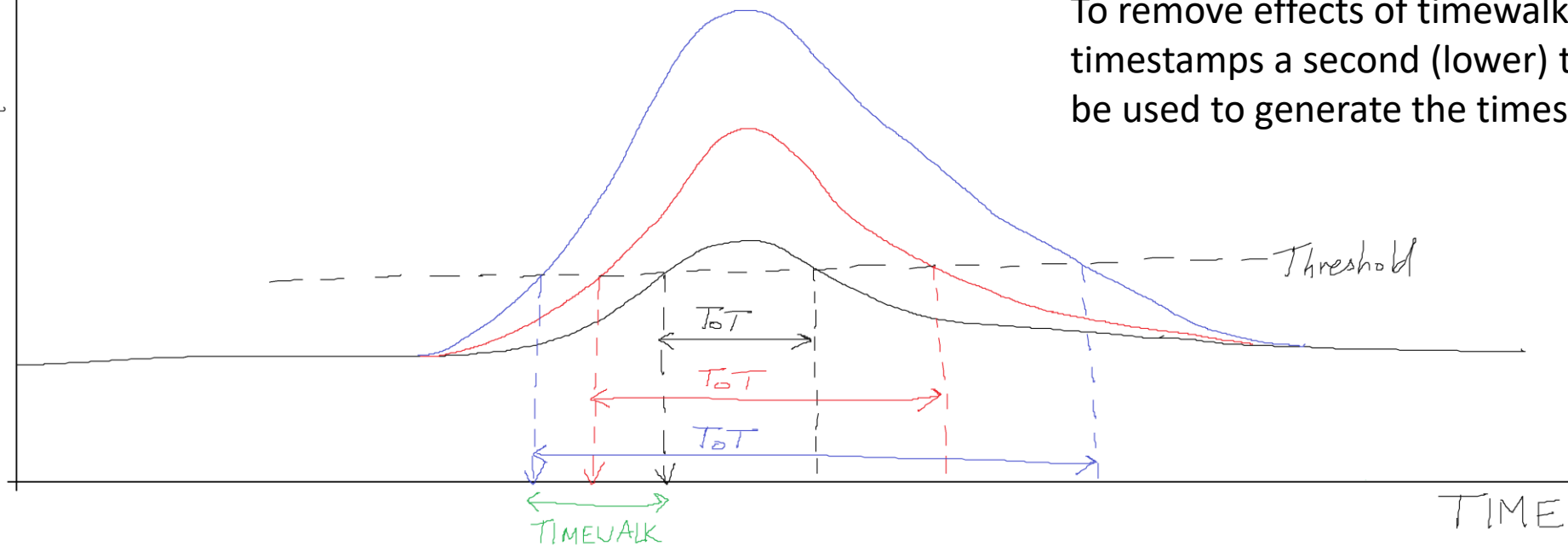



PART 3: LAYOUT

Layout

- Ultimately what we care about is physics and how tracker performance affects physics analysis
- This comes down to simulating layouts and performing analyses on Monte Carlo to see what layouts work best
- Always a collaborative effort between the physics simulation and engineering design
- A few things to keep an eye on when designing a layout:
 - d_0 resolution
 - z_0 resolution
 - p_T resolution
 - Hemiticity
 - Tracking efficiency
 - Redundancy

d_0 and z_0

Both improved by a low radius first layer (and optimised second layer radius)

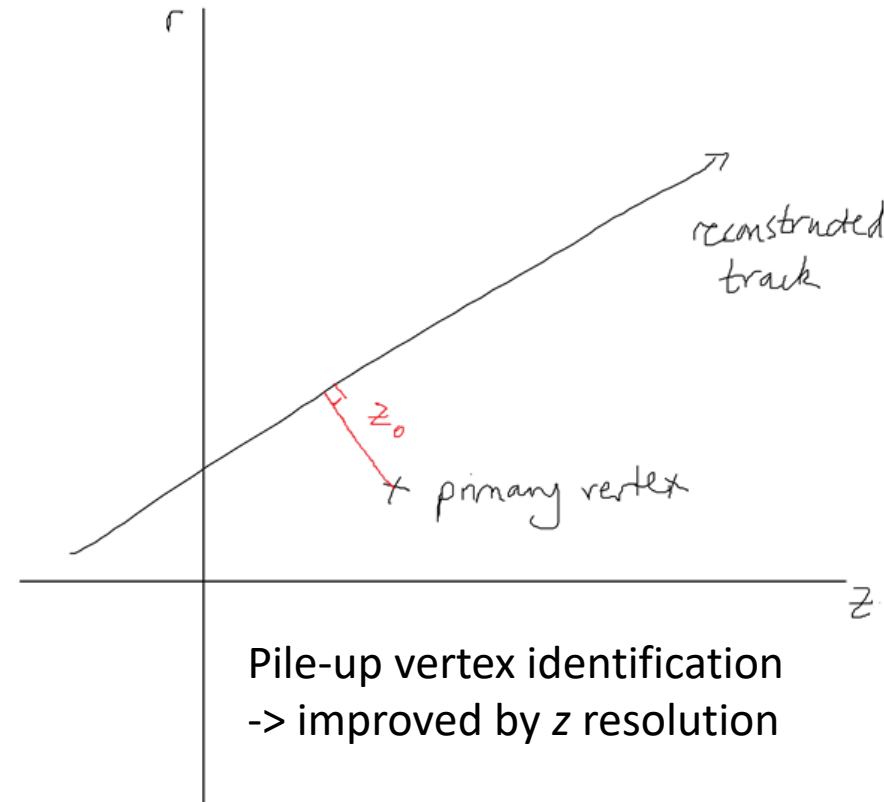
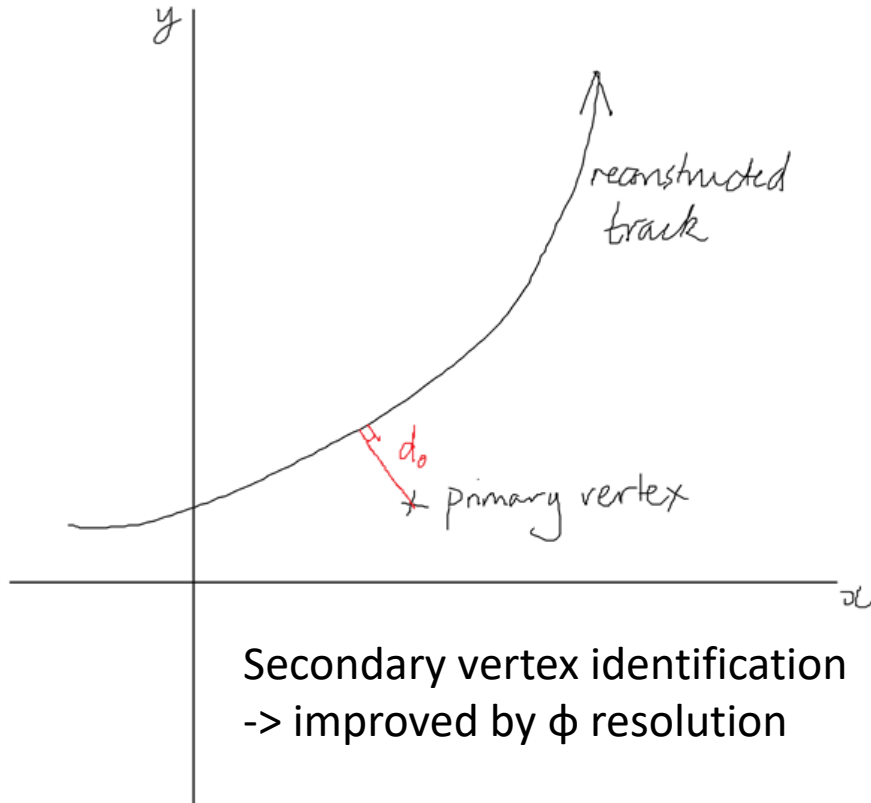

p_T resolution

- For best p_T resolution want to measure the sagitta, S , as well as possible
 - $p_T = 100$ GeV, $B = 2$ T, $L = 1$ m
 - $S = 0.75$ mm
- Measurement improved by
 - Strong magnetic field
 - ϕ resolution
 - Large number of hits on track
 - Minimal scattering
 - Long lever arm
 - Distance between first and last hit

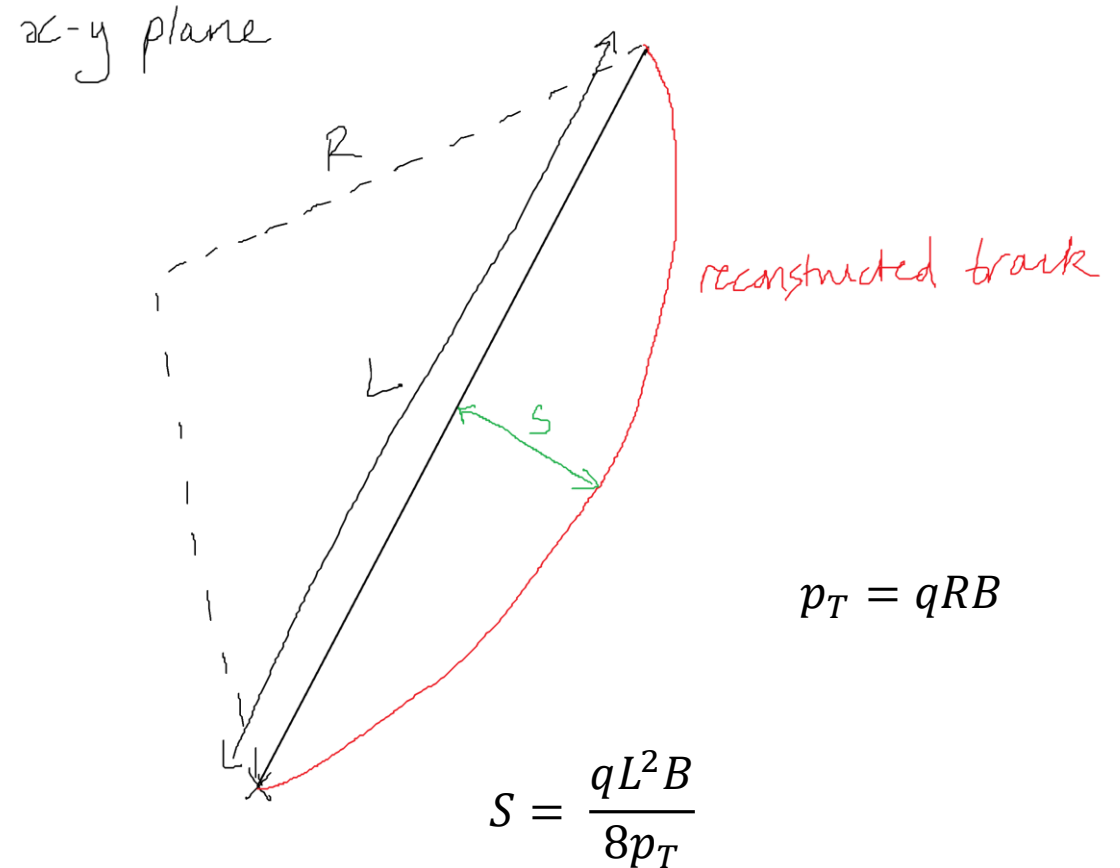

A full layout

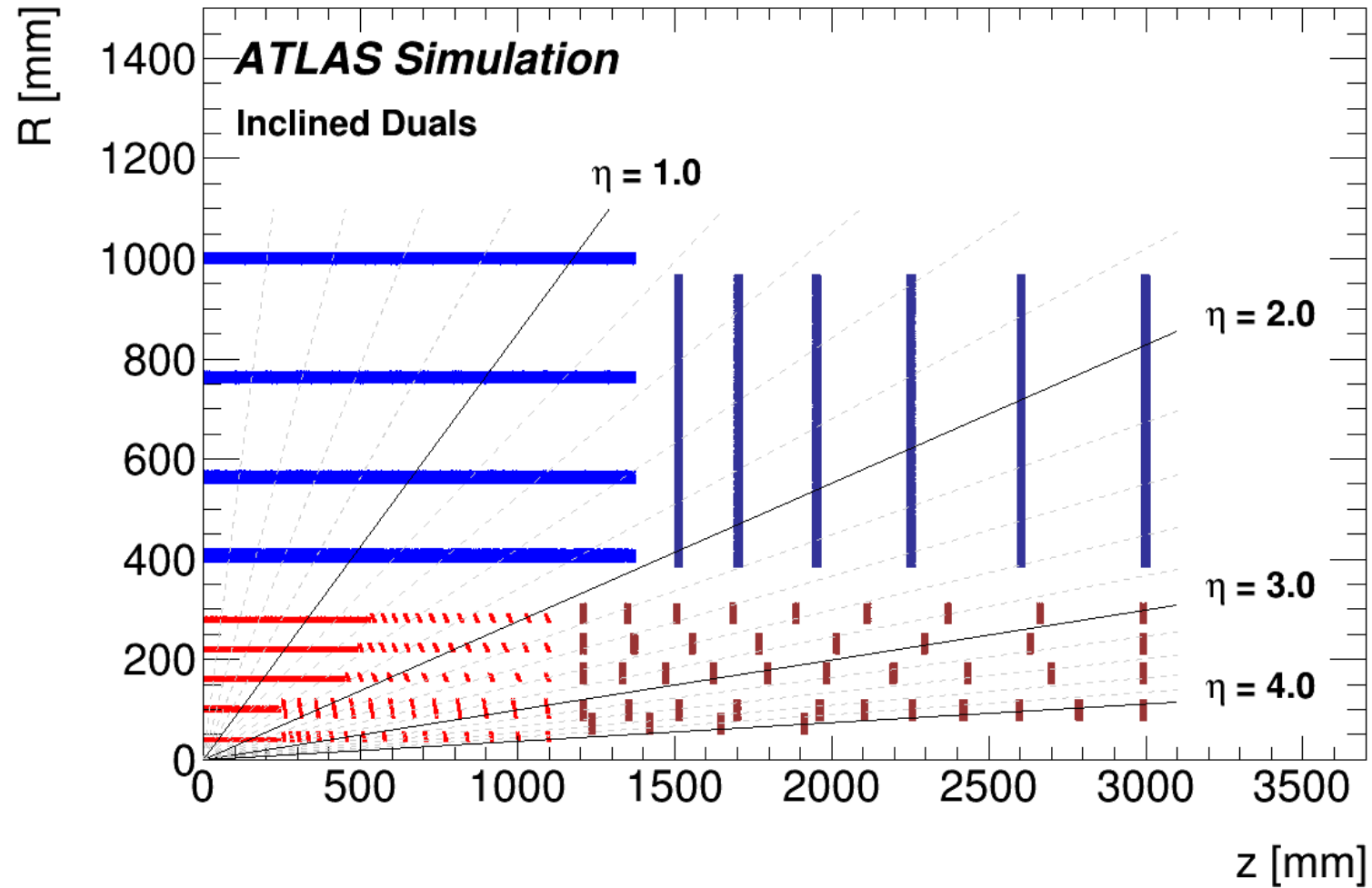

A full layout

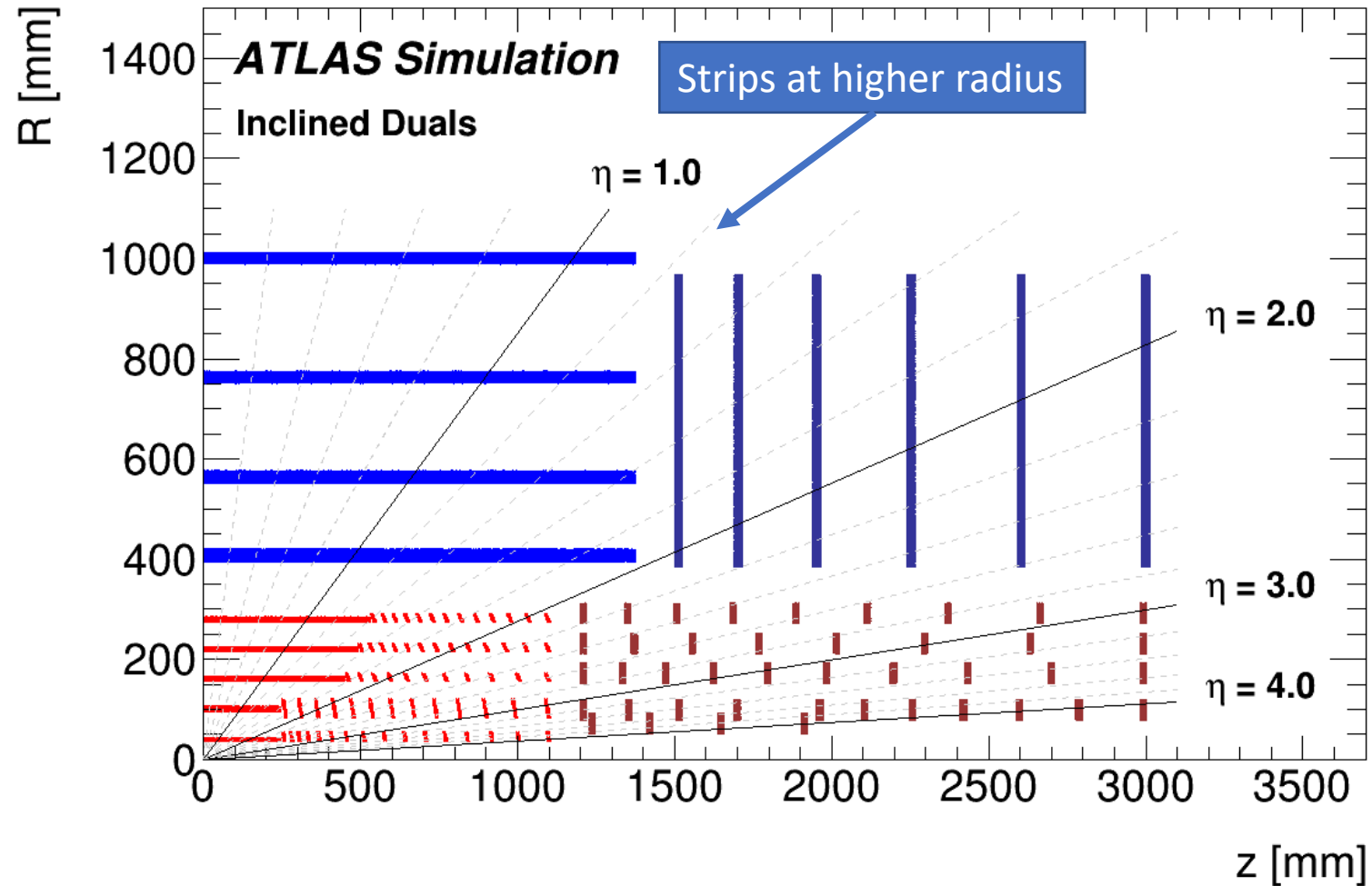

A full layout

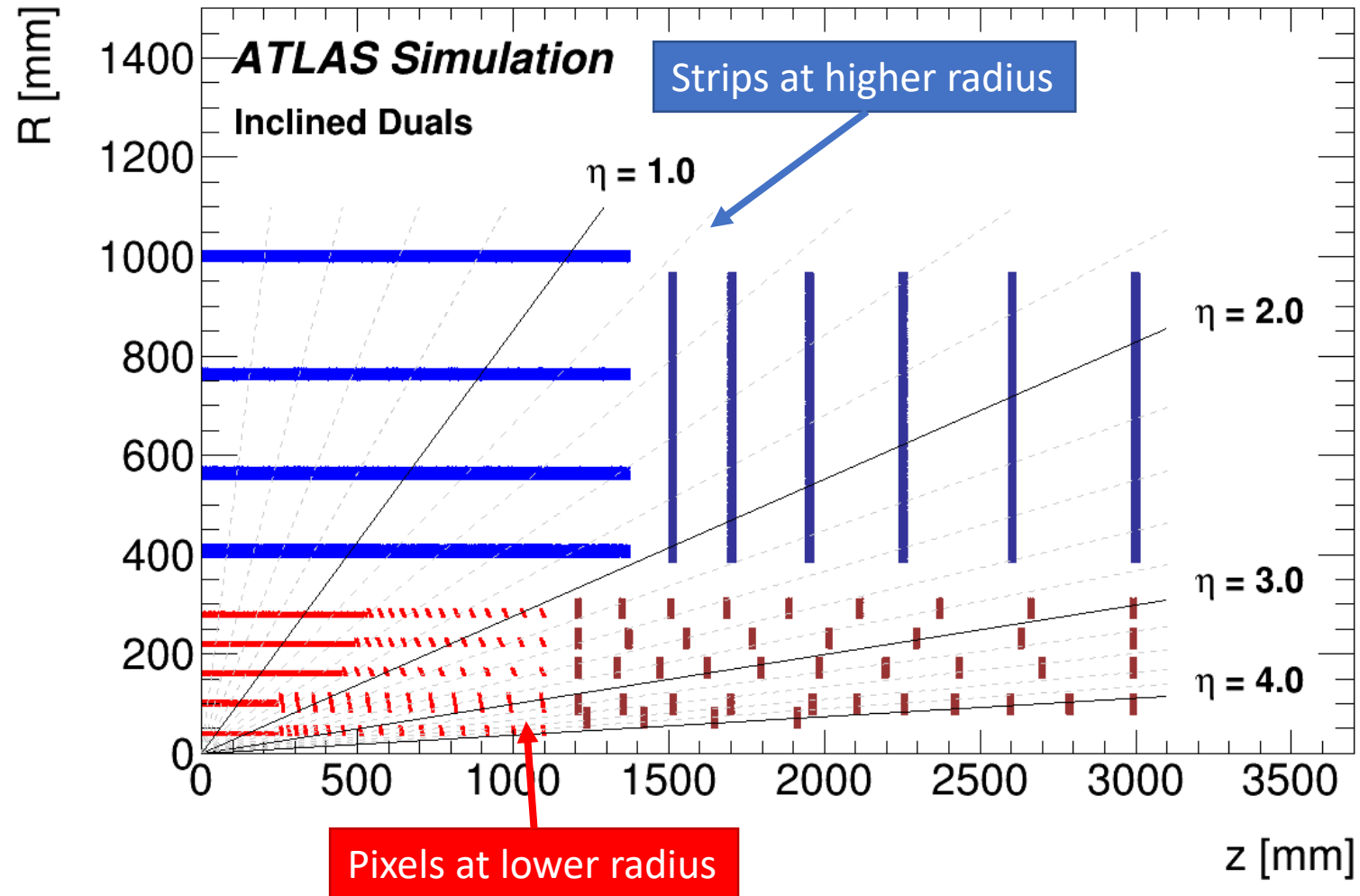

A full layout

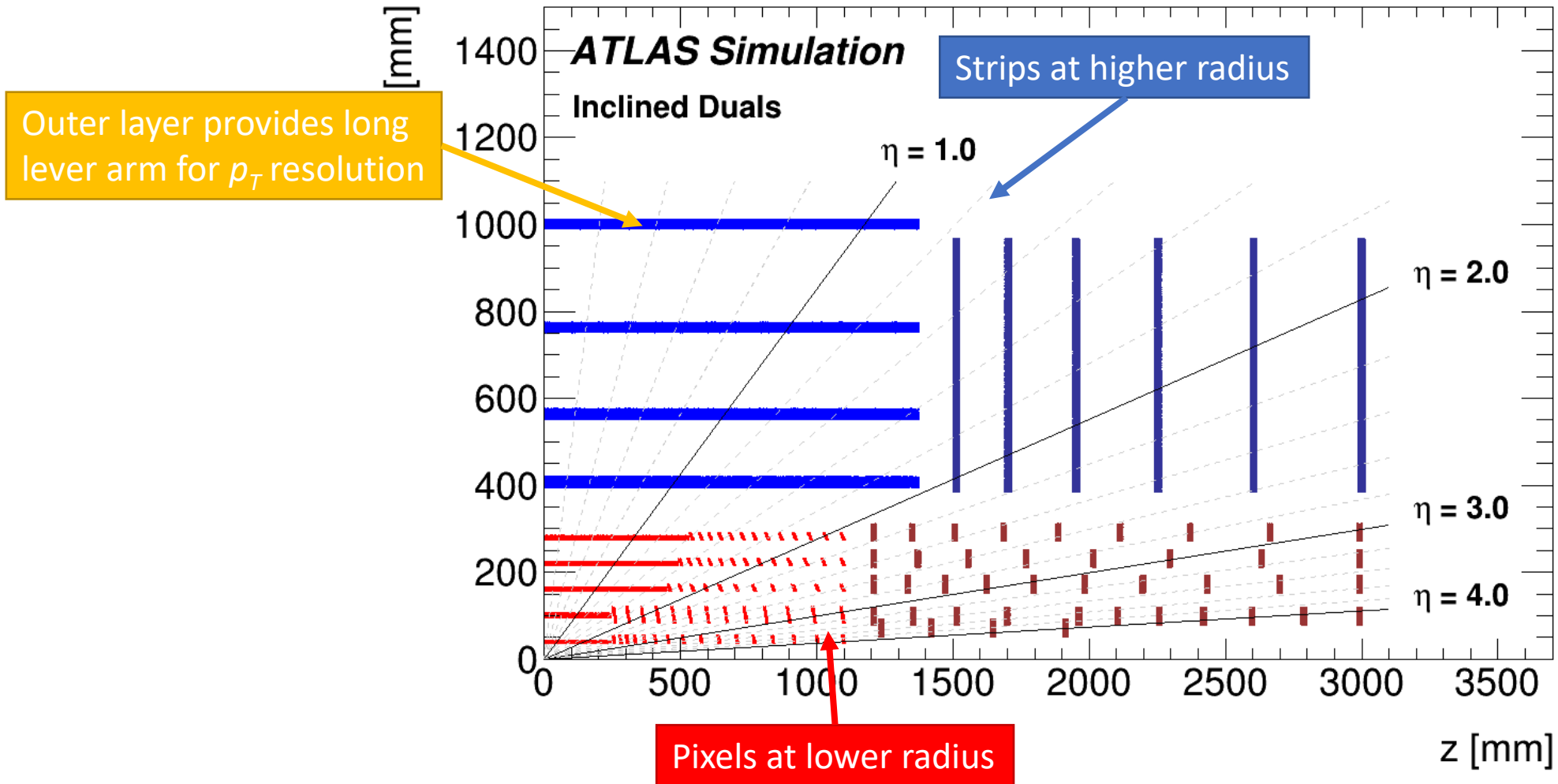

A full layout

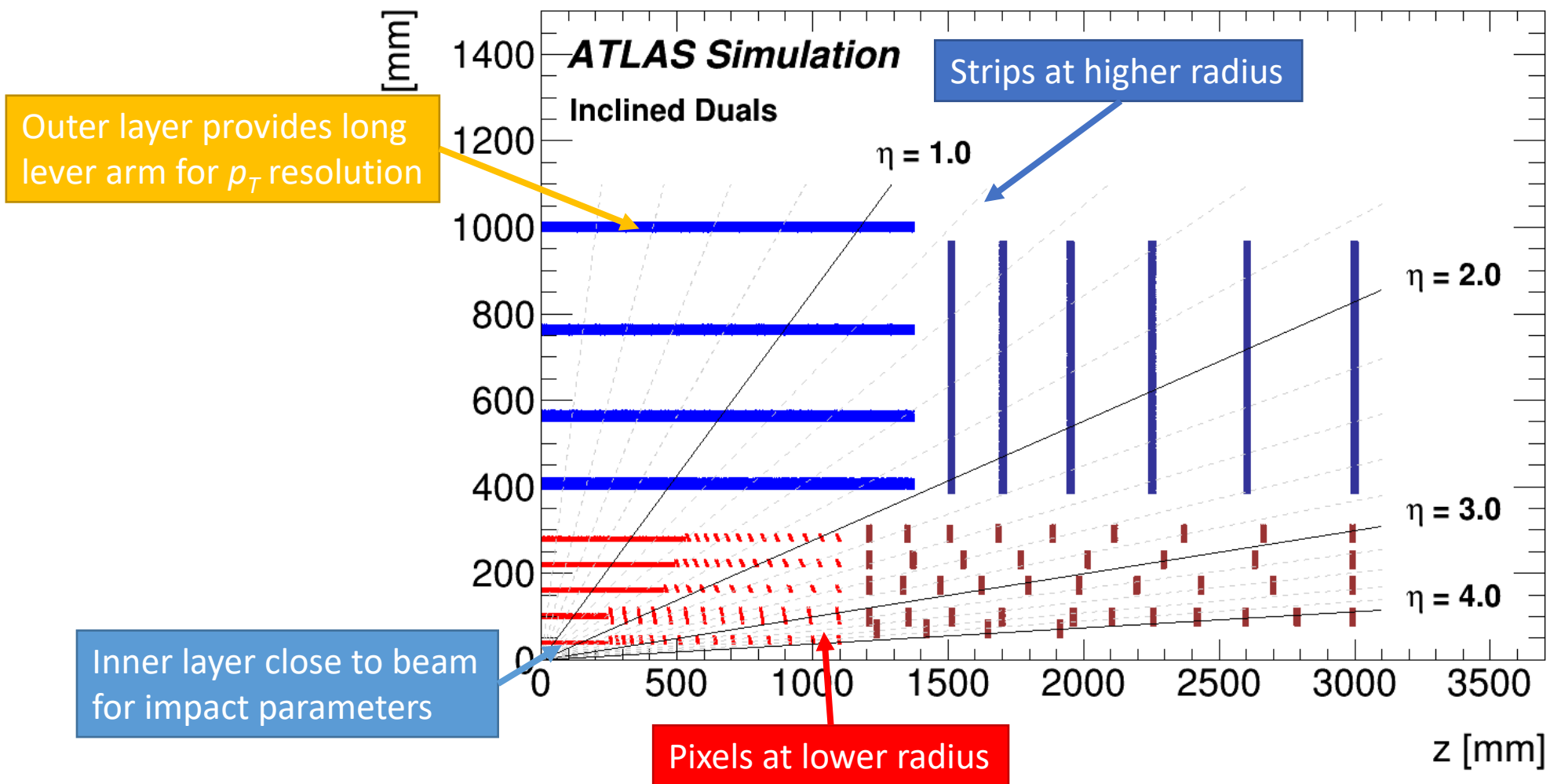

A full layout

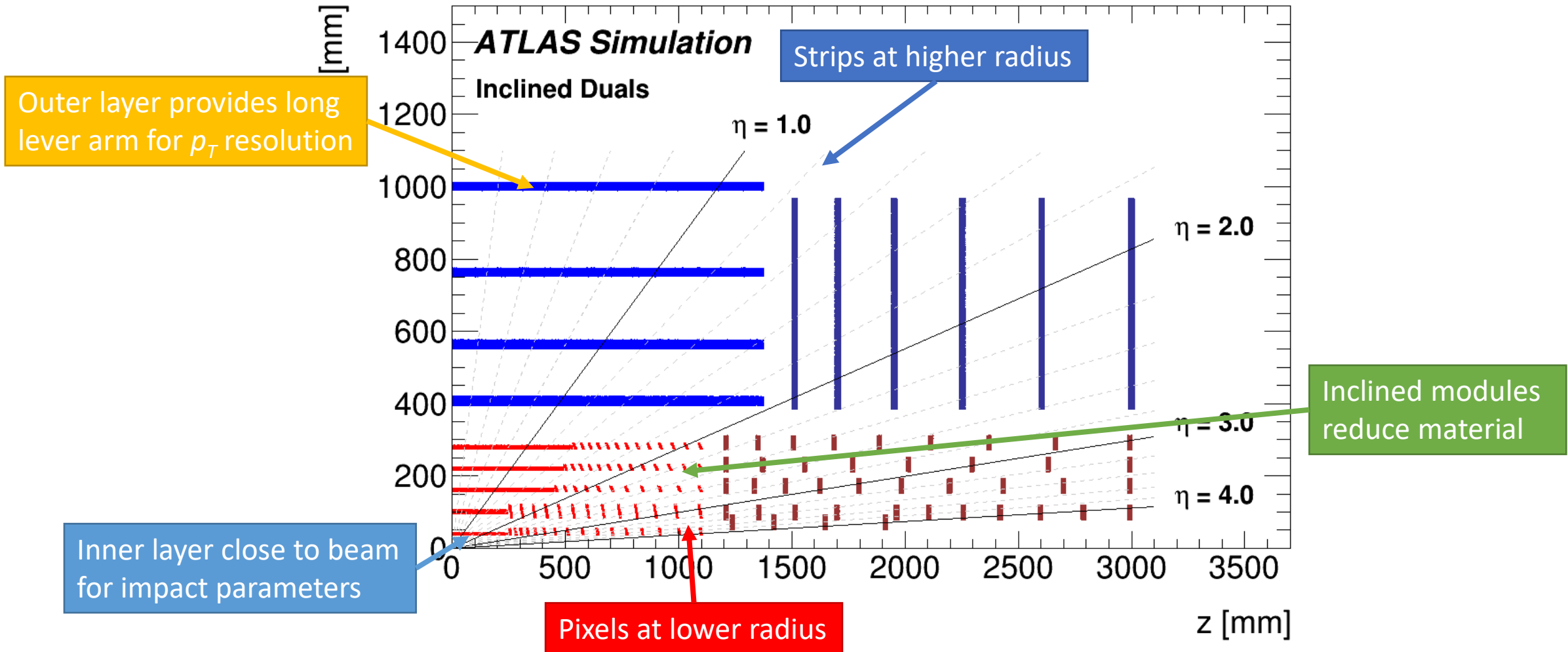

A full layout

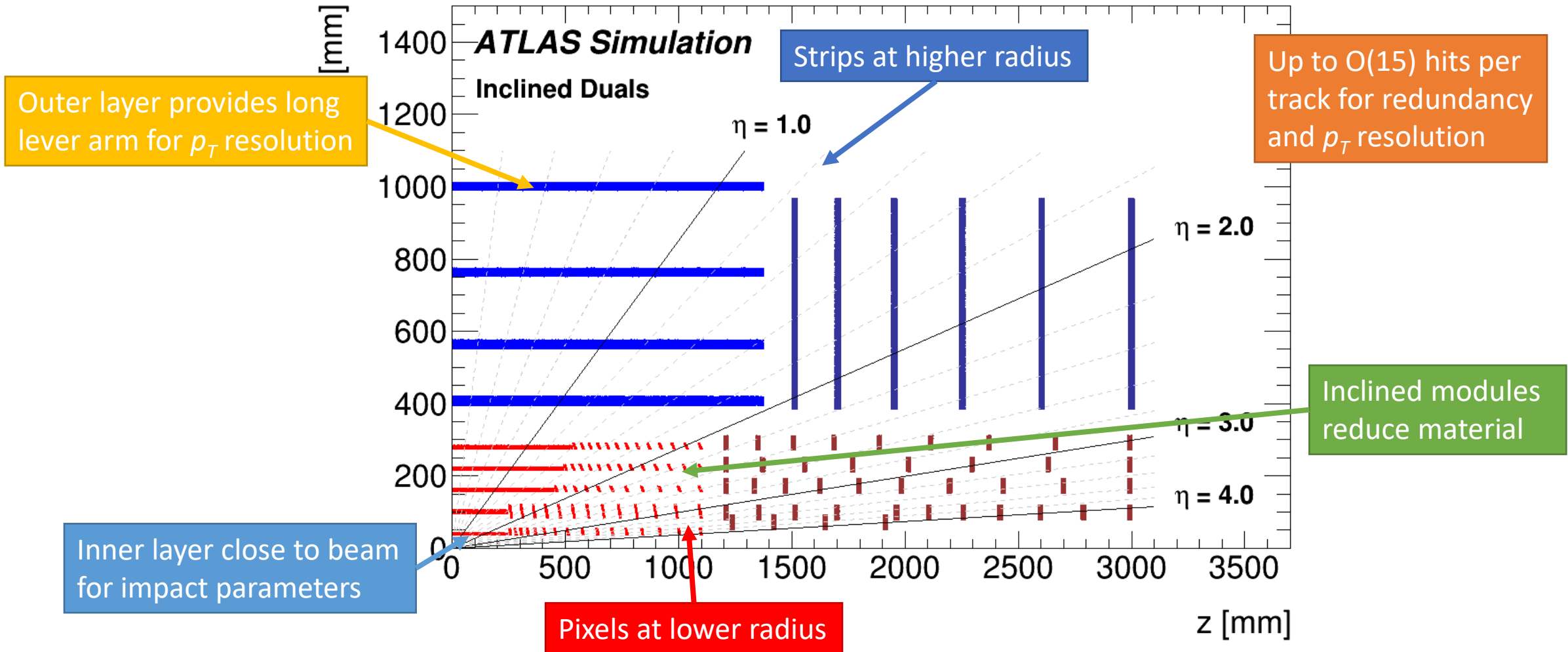



PART 4: BUILDING A DETECTOR

How do we build a detector?

- Typically two routes to building modules
 - Industry partners
 - In house at institutes
- Productions seem big when you are in the midst of it (ITk strips contains 17,888 modules) but this is small fry to industry
- Our requirements often very different from “everyday” industry
 - Harsh radiation environment
 - 10+ year lifetime
 - Stringent quality control
 - High yield, low cost
- As a result much of production is done in house which comes with its own challenges
 - Requires high skill level personnel
 - Many institutes needed to build enough parts in the required time eg. 21 institutes world wide in 9 countries for ITk strips
 - Cross calibration of institutes (and funding agencies!) is complex
 - Many automated machines are expensive so simplicity is key
 - Have to ensure that everyone is building (and adhering) to the same specifications/procedures
 - Parts must be sent international between sites (logistics and customs!)

Module and tooling examples (glue is king!)

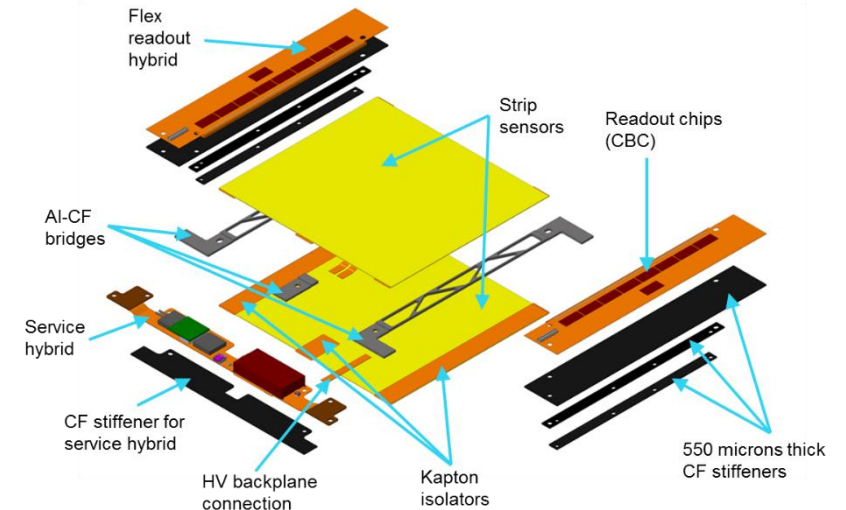
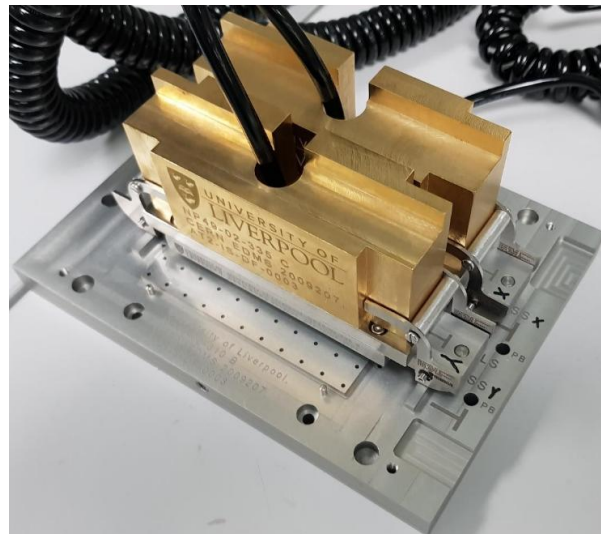
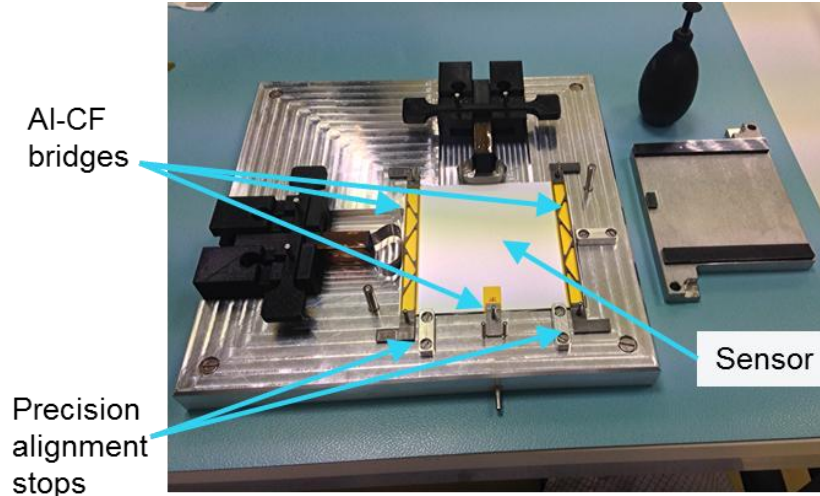
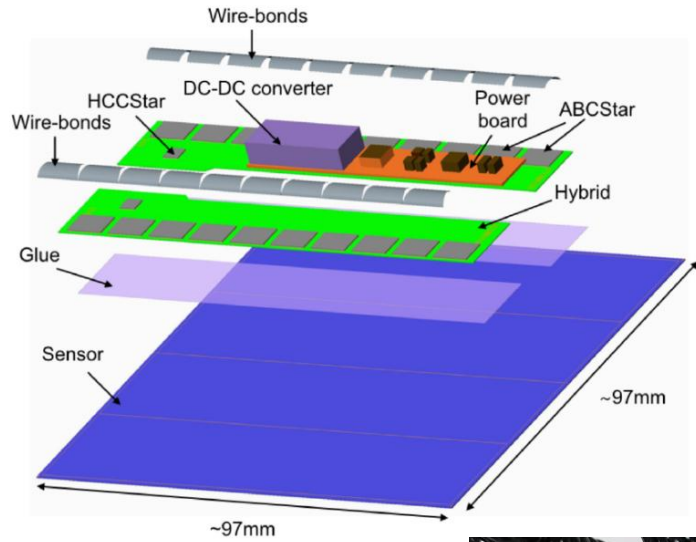

How do we integrate modules into a detector?

- There are two primary ways to integrate modules into a detector
 - **Modules act as a standalone entity which gets integrated directly onto a structure**
 - Modules get integrated onto a “local support” structure which then goes into the full structure

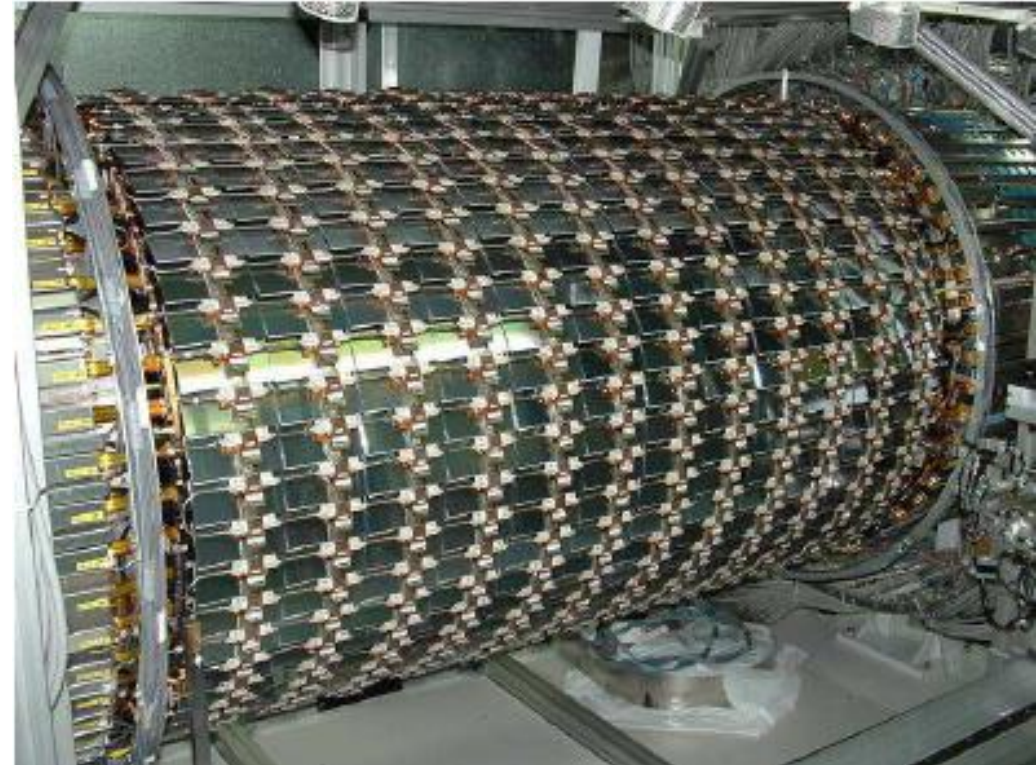
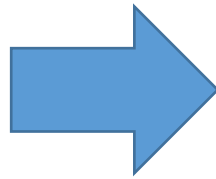
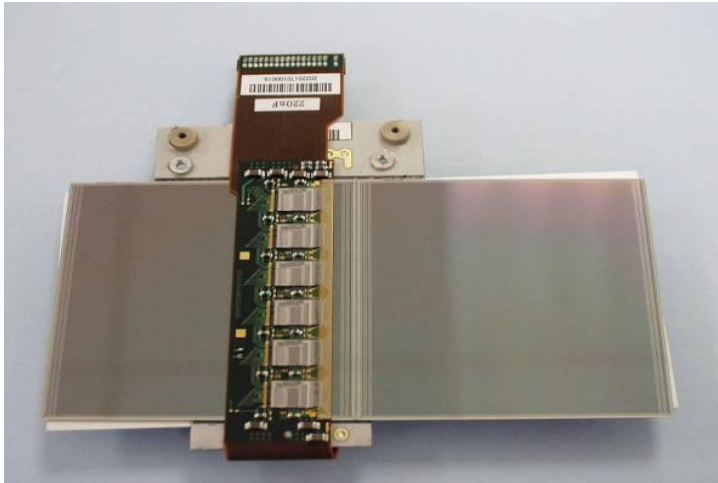

How do we integrate modules into a detector?

- There are multiple ways to integrate modules into a detector
 - Modules act as a standalone entity which gets integrated directly onto a structure
 - ***Modules get integrated onto a “local support” structure which then goes into the full structure***

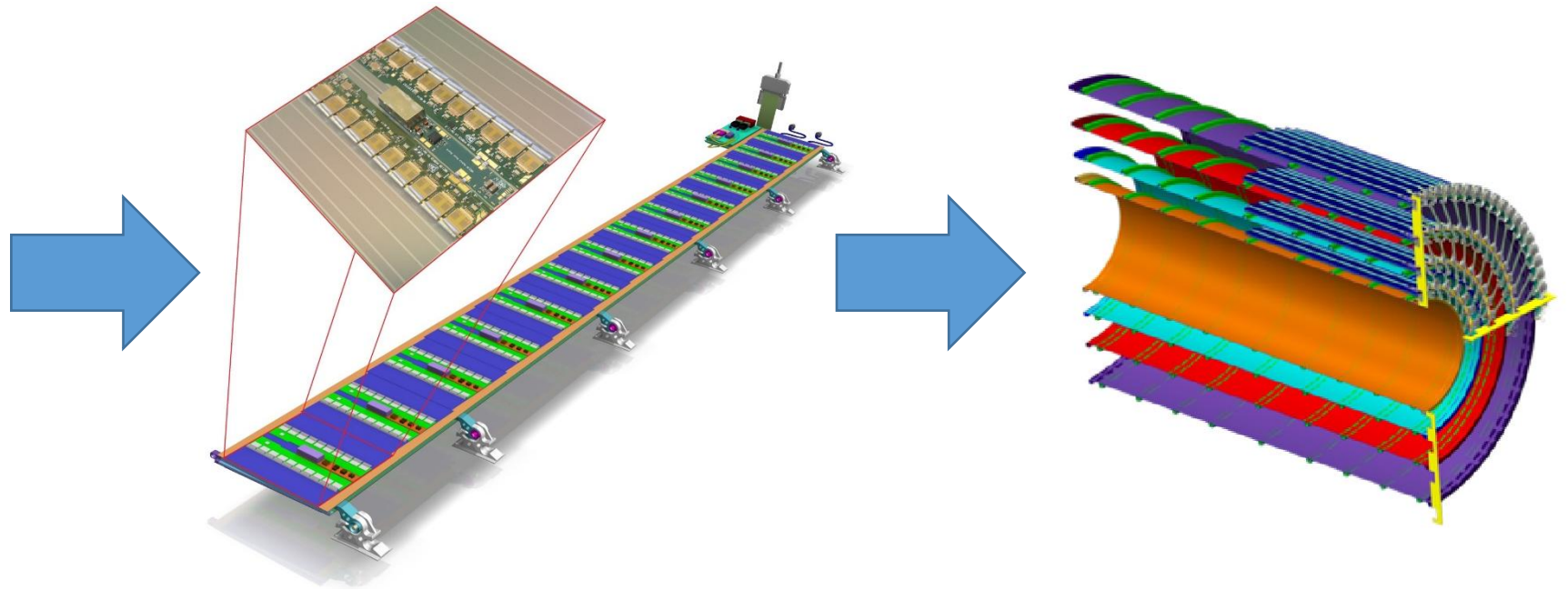
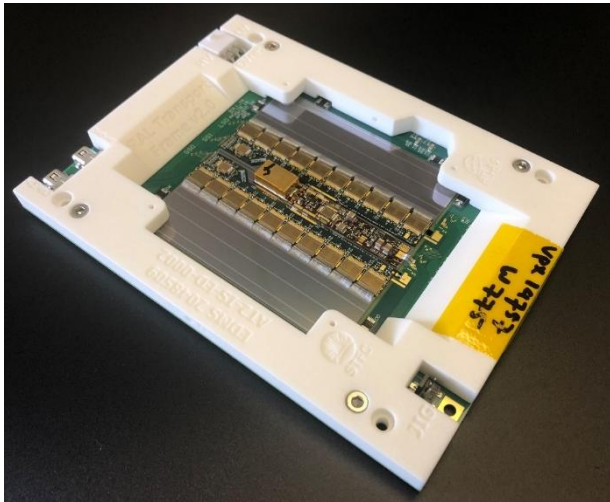

Local support

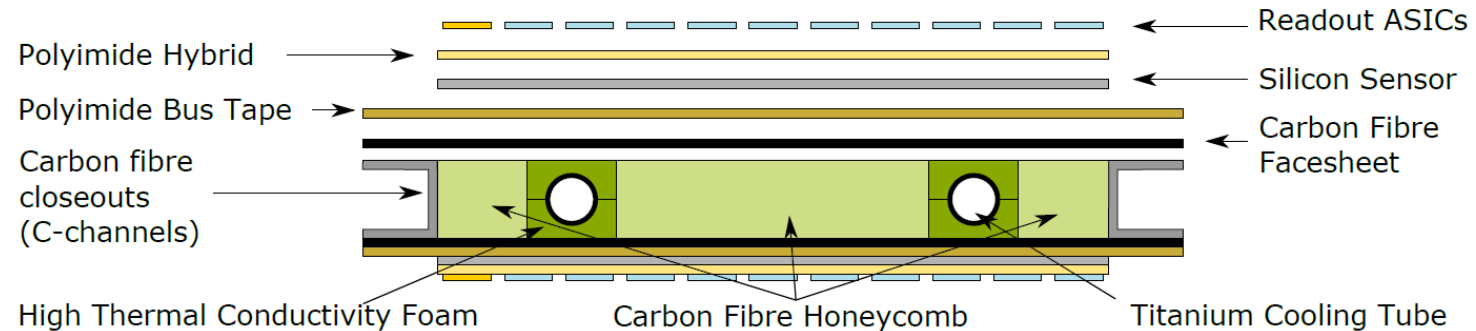

- The local support concept comes into its own as the detector size increases
 - Without it, there is a power and fibre optic cable per module
 - With it, a single power/fibre connection can service a much greater area of detector

How do we service a detector?

- Bringing in services to a detector can be one of the biggest issues for material budget
 - Cooling pipes
 - Support structure (not strictly “service”)
 - Power cables
 - Data cables
 - Patch panels
- It’s one thing to have perfect low mass silicon detectors, it takes a lot more engineering to cool them, power them and hold them stable!

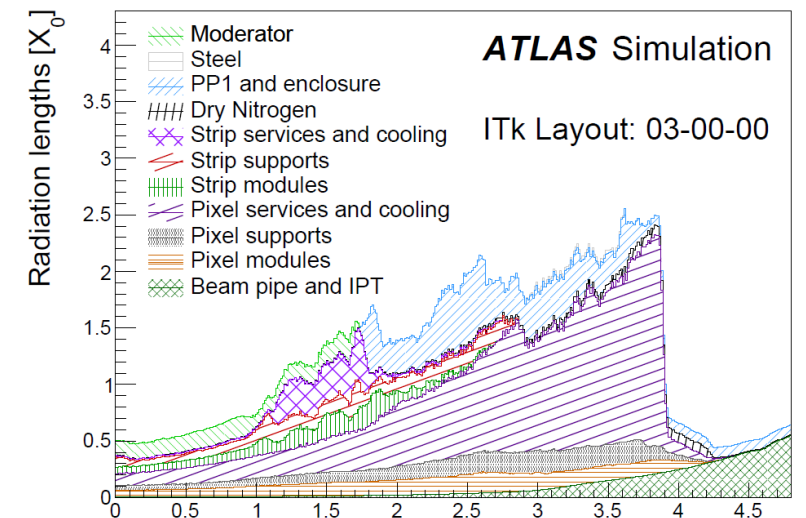
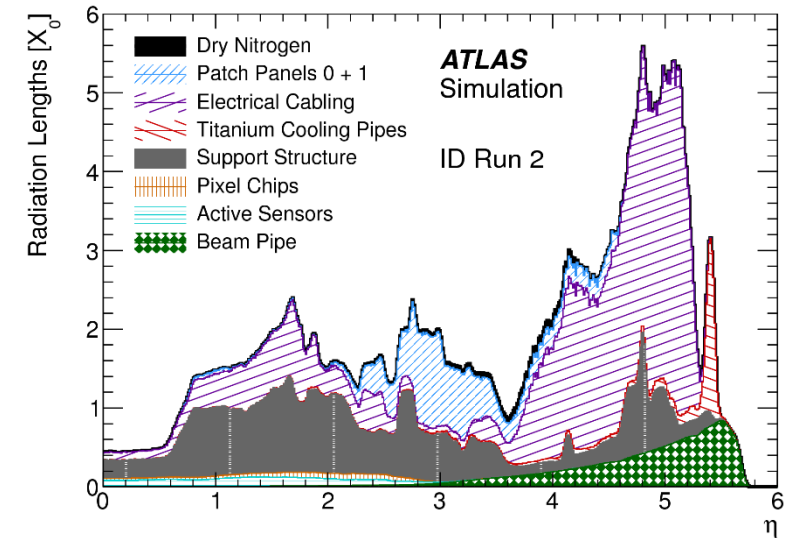



PART 5: THE REALITY

The Realities of Designing/Building a Detector

- Each time you ramp up the number of things you are building or testing, you invariably find rarer and rarer “effects”
- Throughout R&D and early production there is a lot of problem solving
 - Some problems get solved quickly, some take a bit longer!!
- Great opportunities to learn new skills and play with fun toys

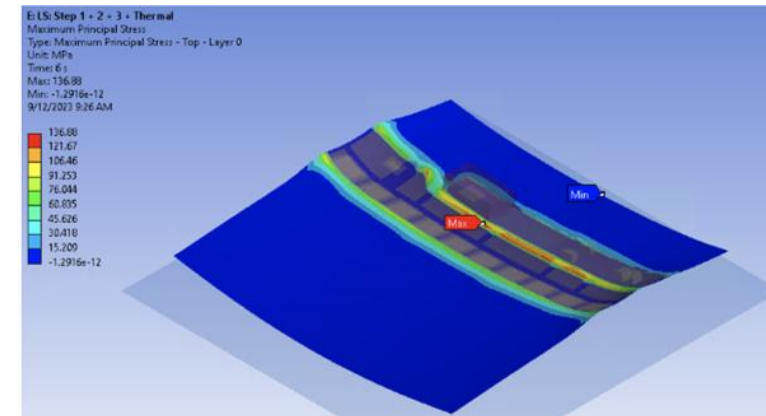
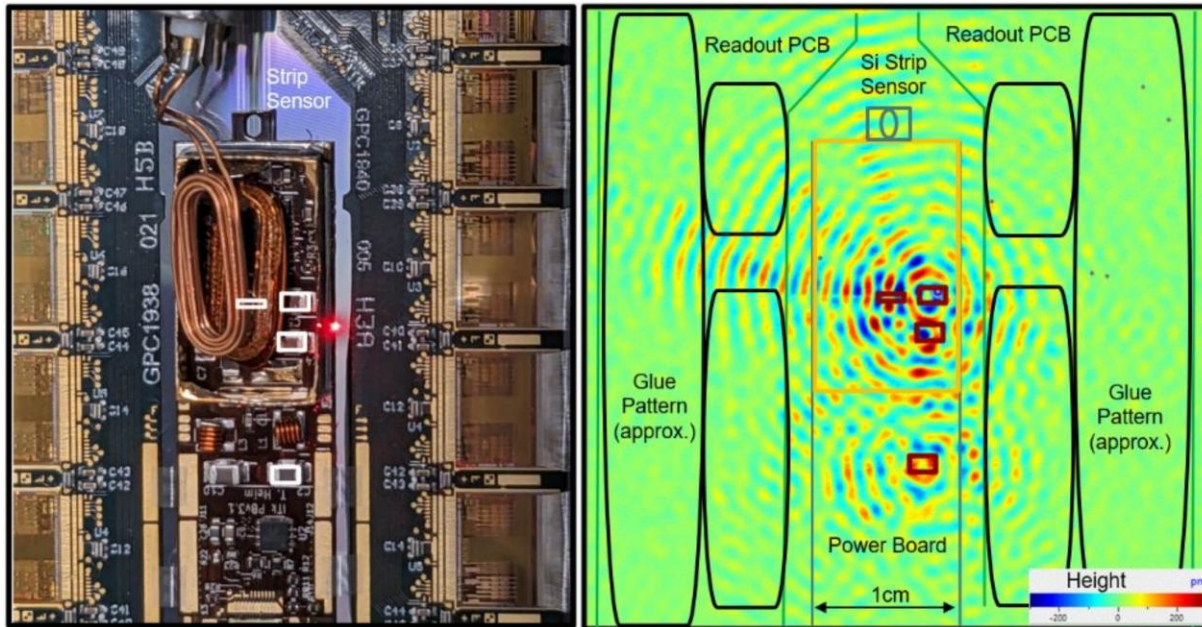

Option #1: Hysol



Option #2: Interposers



The realities of running a detector

Monitoring things you expected...

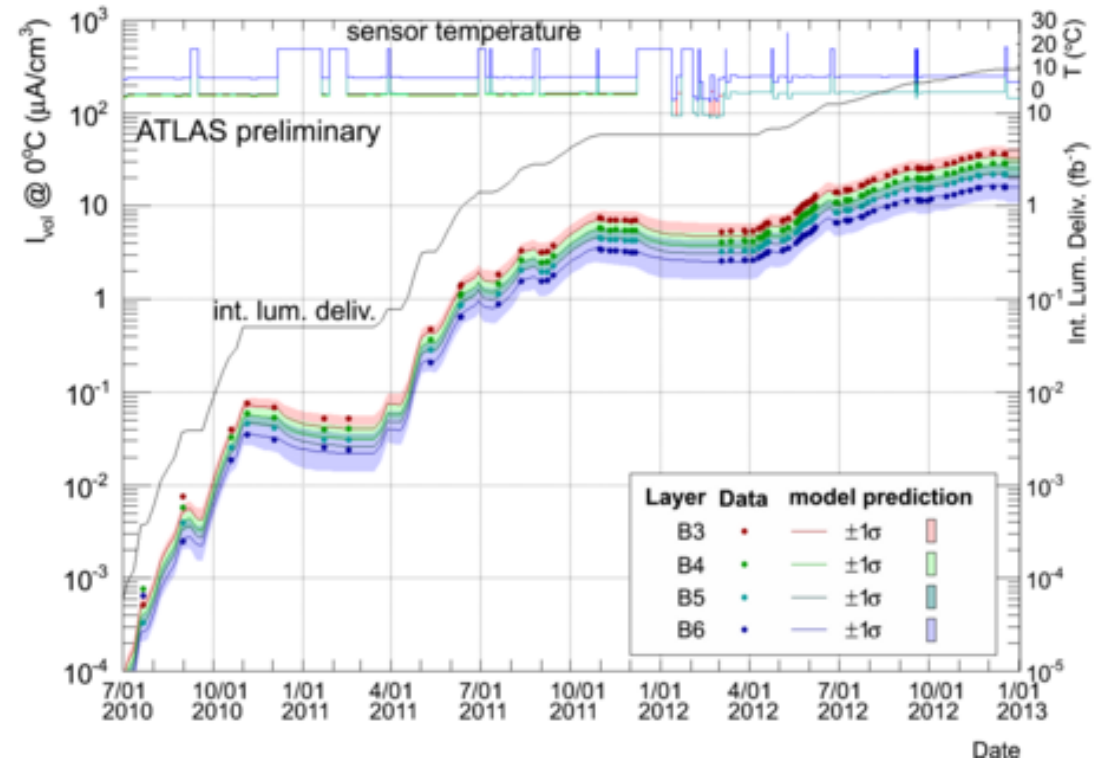
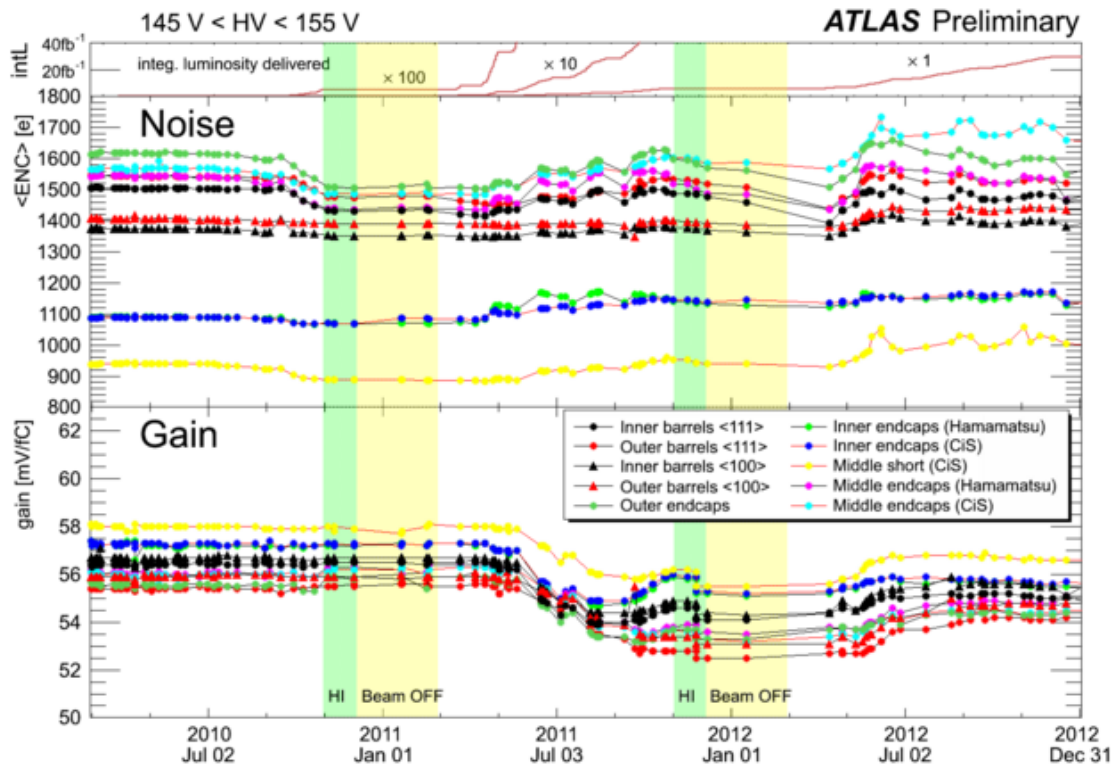

The realities of running a detector

... and discovering those you didn't

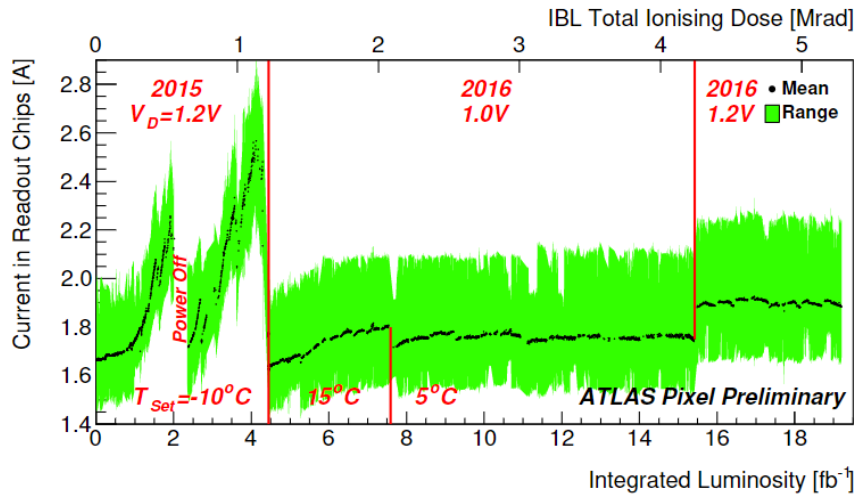
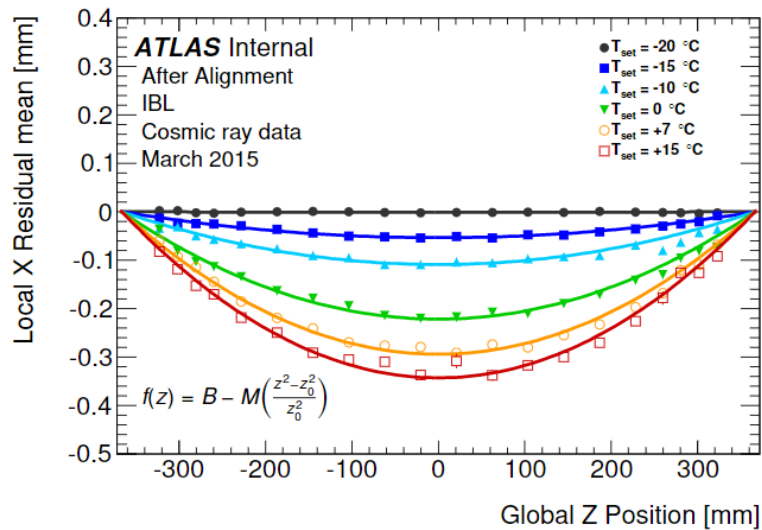

Perfectly working in the system but found to have anomalous current when tested

Pixel Names	Number of Converters	Tested Broken	Tested working with High Current	Tested working with normal current	BROKEN	HIGH CURRENT
					% with respect to total	% with respect to total working
		"BROKEN"	"HIGH CURRENT"	"GOOD"		
BPIX (+Z, Near)	BPIX-Bpl	208	4	48	1.9	23.5
BPIX (-Z, Near)	BPIX-Bml	208	10	48	4.8	24.2
BPIX (+Z, Far)	BPIX-BpO	208	13	70	6.3	35.9
BPIX (-Z, Far)	BPIX-BmO	208	11	70	5.3	35.5
FPIX (+Z, Near)	FPIX-Bpl	96	7	41	7.3	46.1
FPIX (-Z, Near)	FPIX-Bml	96	7	34	7.3	38.2
FPIX (+Z, Far)	FPIX-BpO	96	9	23	9.4	26.4
FPIX (-Z, Far)	FPIX-BmO	96	6	22	6.3	24.4
BPIX - not connected to modules		32	2	8	6.3	26.7



PART 6: THE FUTURE

Challenges of the future

Parameter \ Exp.	LHC	HL-LHC	SPS	FCC-hh	FCC-ee	CLIC 3 TeV
Fluence [$n_{eq}/cm^2/y$]	$N \times 10^{15}$	10^{16}	10^{17}	$10^{16} - 10^{17}$	$<10^{10}$	$<10^{11}$
Max. hit rate [$s^{-1}cm^{-2}$]	100 M	2-4 G ^{****)}	8 G ^{****)}	20 G	20 M ^{***)}	240k
Surface inner tracker [m^2]	2	10	0.2	15	1	1
Surface outer tracker [m^2]	200	200	-	400	200	140
Material budget per detection layer [X_0]	0.3% ^{*)} - 2%	0.1% ^{*)} - 2%	2%	1%	0.3%	0.2%
Pixel size inner layers [μm^2]	100x150-50x400	$\sim 50 \times 50$	$\sim 50 \times 50$	25x50	25x25	$< \sim 25 \times 25$
BC spacing [ns]	25	25	$>10^9$	25	20-3400	0.5
Hit time resolution [ns]	$< \sim 25 - 1k$ ^{*)}	0.2 ^{**)} - $1k$ ^{*)}	0.04	$\sim 10^{-2}$	$\sim 1k$ ^{***)}	~ 5

*) ALICE requirement **) LHCb requirement ***) At Z-pole running ****) max. output rate for LHCb/high intensity flavour experiments: 300-400 Gbit/s/cm²

- Hadron colliders

- Radiation levels $\leq 10^{18} n_{eq}/cm^2$
- High hit rates
- Precision timing ≤ 5 ps

- Lepton colliders

- Small single point resolution $\leq 3 \mu m$
- Very low material budget $\leq 0.2\% X_0 / layer$

<https://cds.cern.ch/record/2649646/>

(D)MAPS/CMOS?

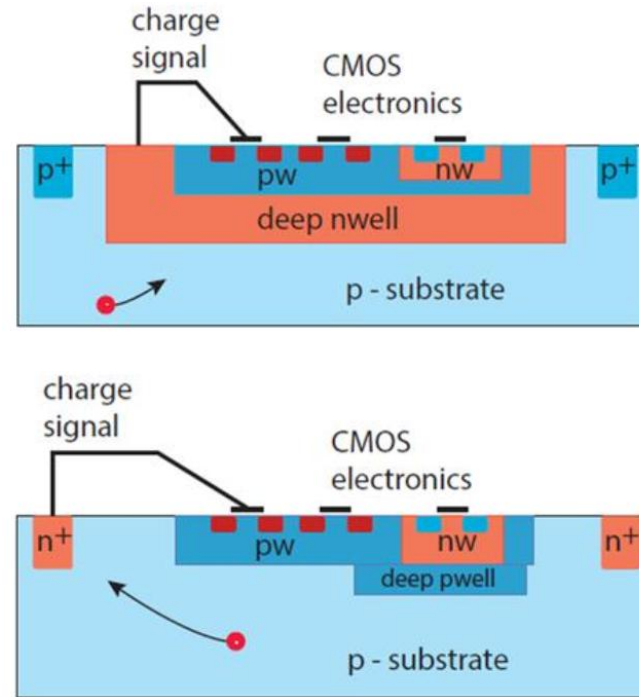
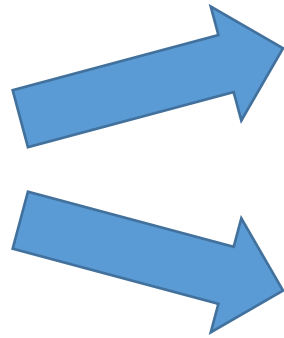
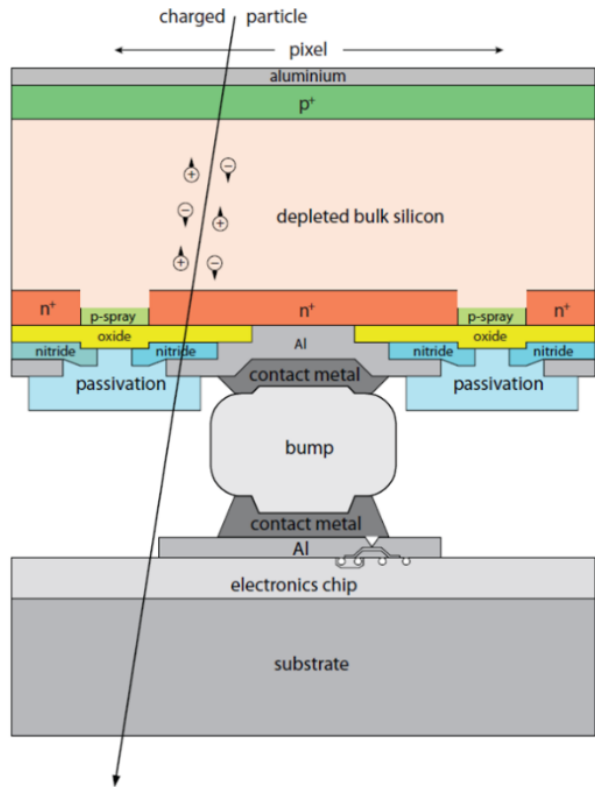

- SINGLE WAFER PROCESS
- REDUCED MATERIAL
- SMALL PIXEL SIZE
- FAST PRODUCTION
- HIGH YIELD
- CHEAP!!!

Examples of MAPS in HEP

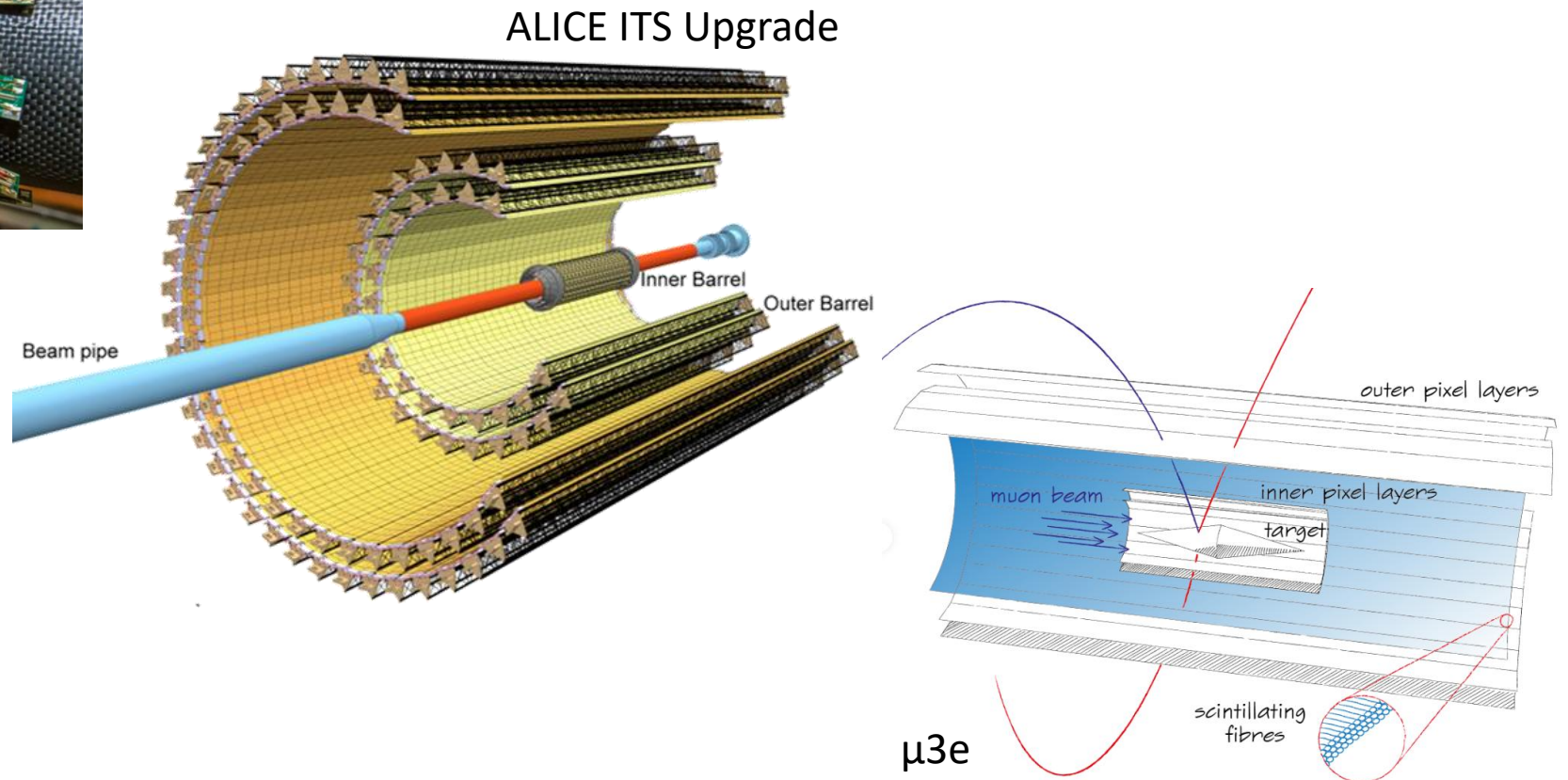
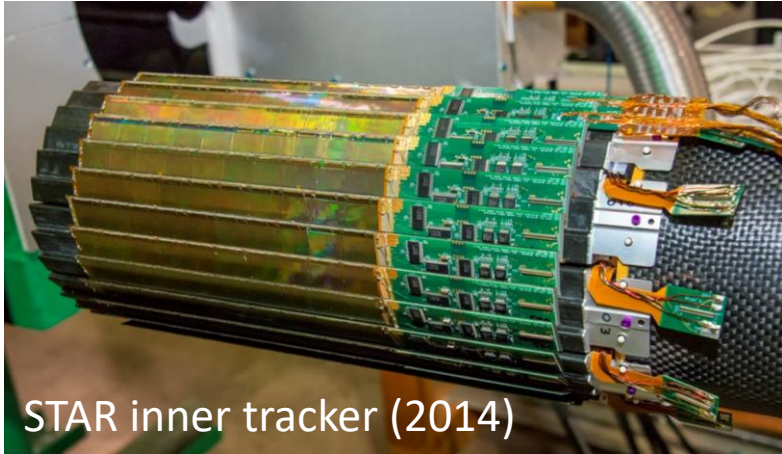

Want to learn more?

