

Development of novel SiPM-based $\text{LaBr}_3(\text{Ce})$ Clover Detector Modules for Nuclear Astrophysics



Sulagna Dutta

PhD Student

Department of Nuclear Physics

University of the West of Scotland

15th April 2026

**IOP Nuclear Physics
Conference**

13-15 April 2026
University of Brighton, Brighton, UK



Astrophysical Motivation: Prompt γ -ray measurements to assist theoretical extrapolation of $S_{34}(0)$ -factor

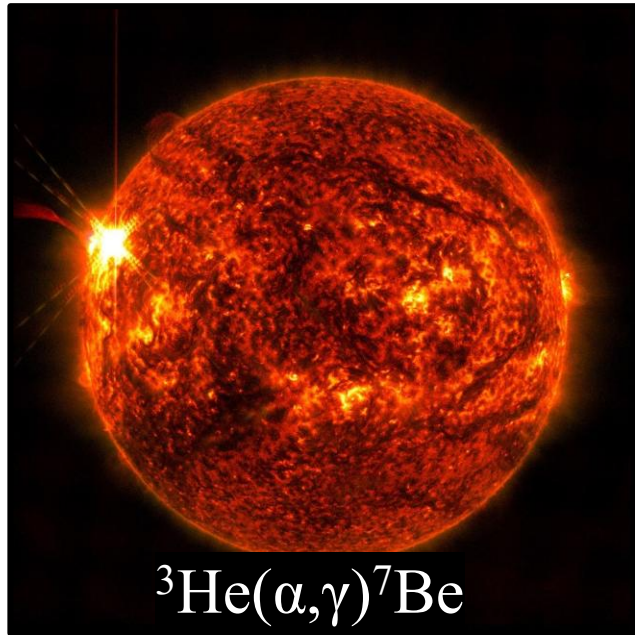

Key pp-chain reaction

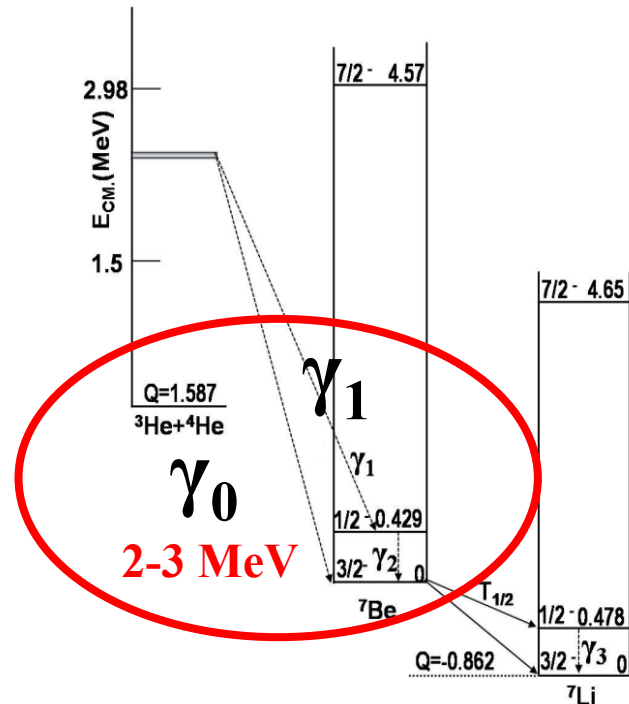

Prompt γ -ray emission

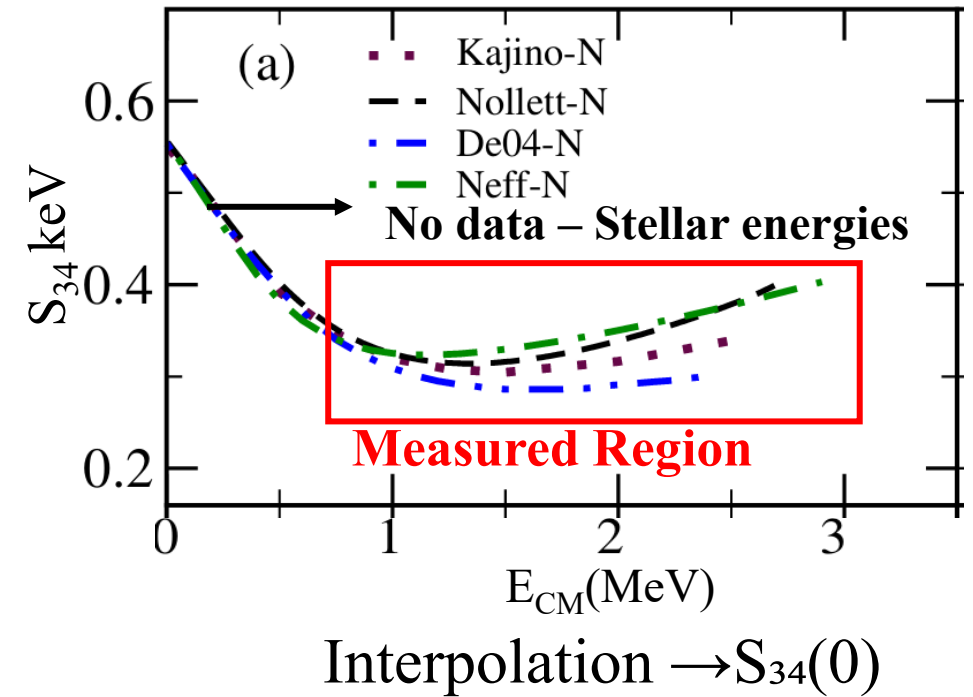

Prompt γ -ray $\rightarrow \sigma(E) \rightarrow S_{34}(E) \rightarrow$ impacts on solar neutrino flux and ${}^7\text{Li}$ abundance
BUT: No data at stellar energies \rightarrow Extrapolation $\rightarrow S_{34}(0)$

Compton Background in γ -ray Measurements

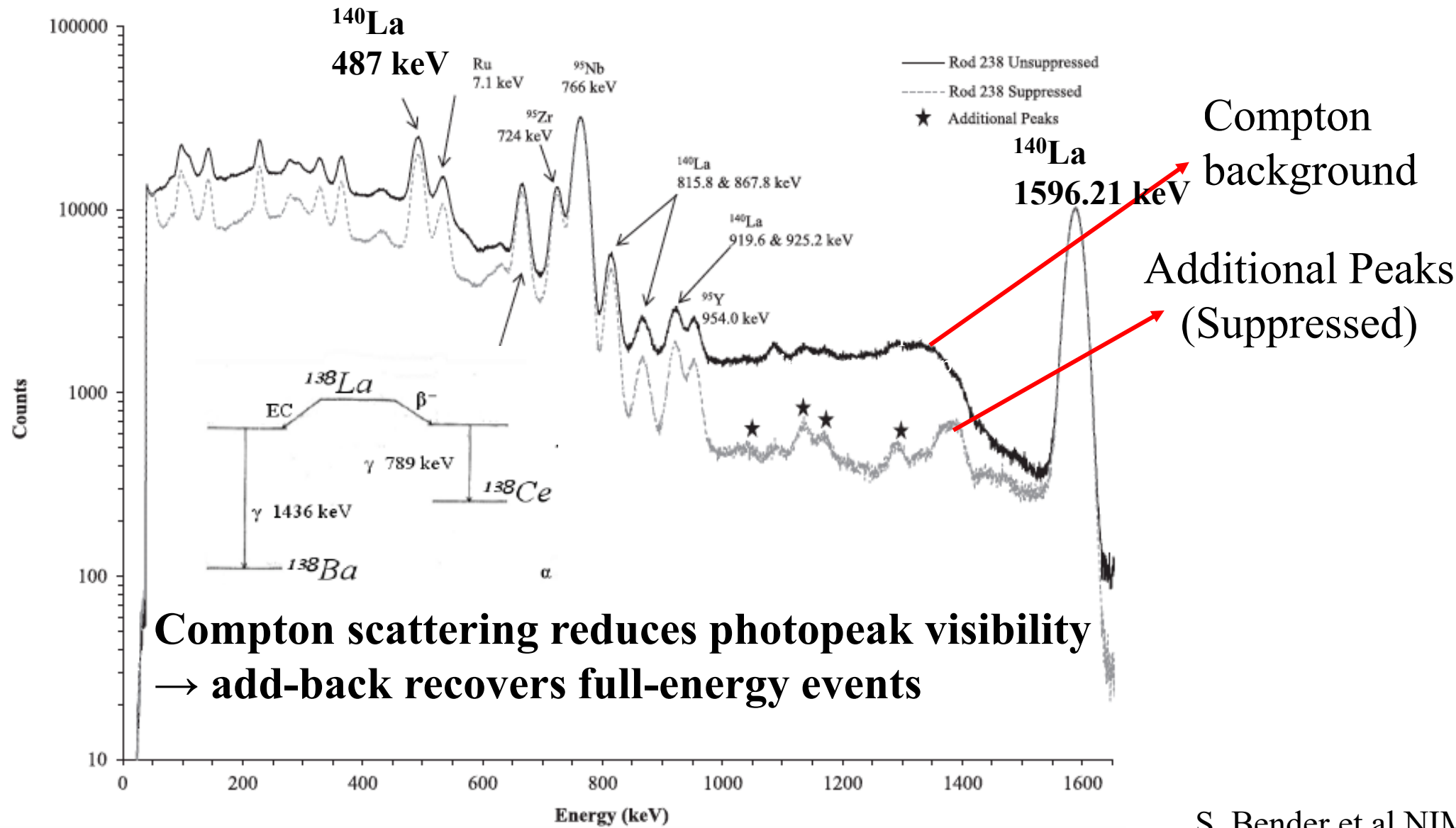

Initial Simulations

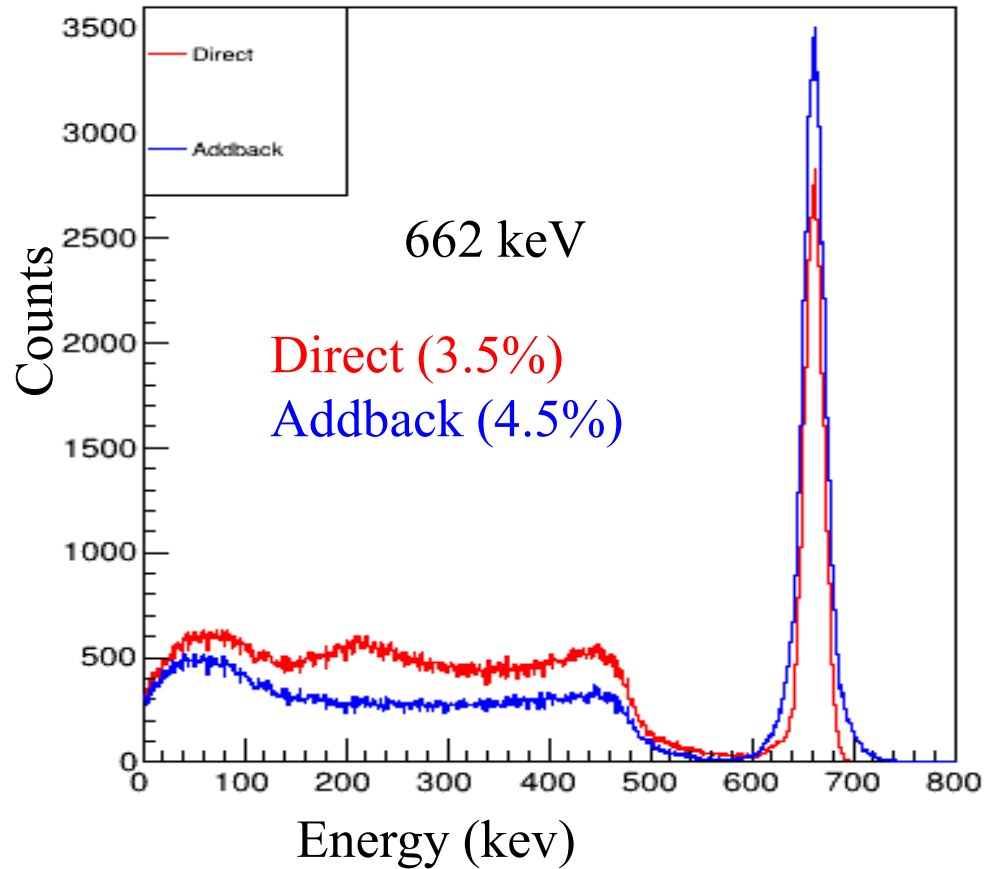

J. Bordes, University of York

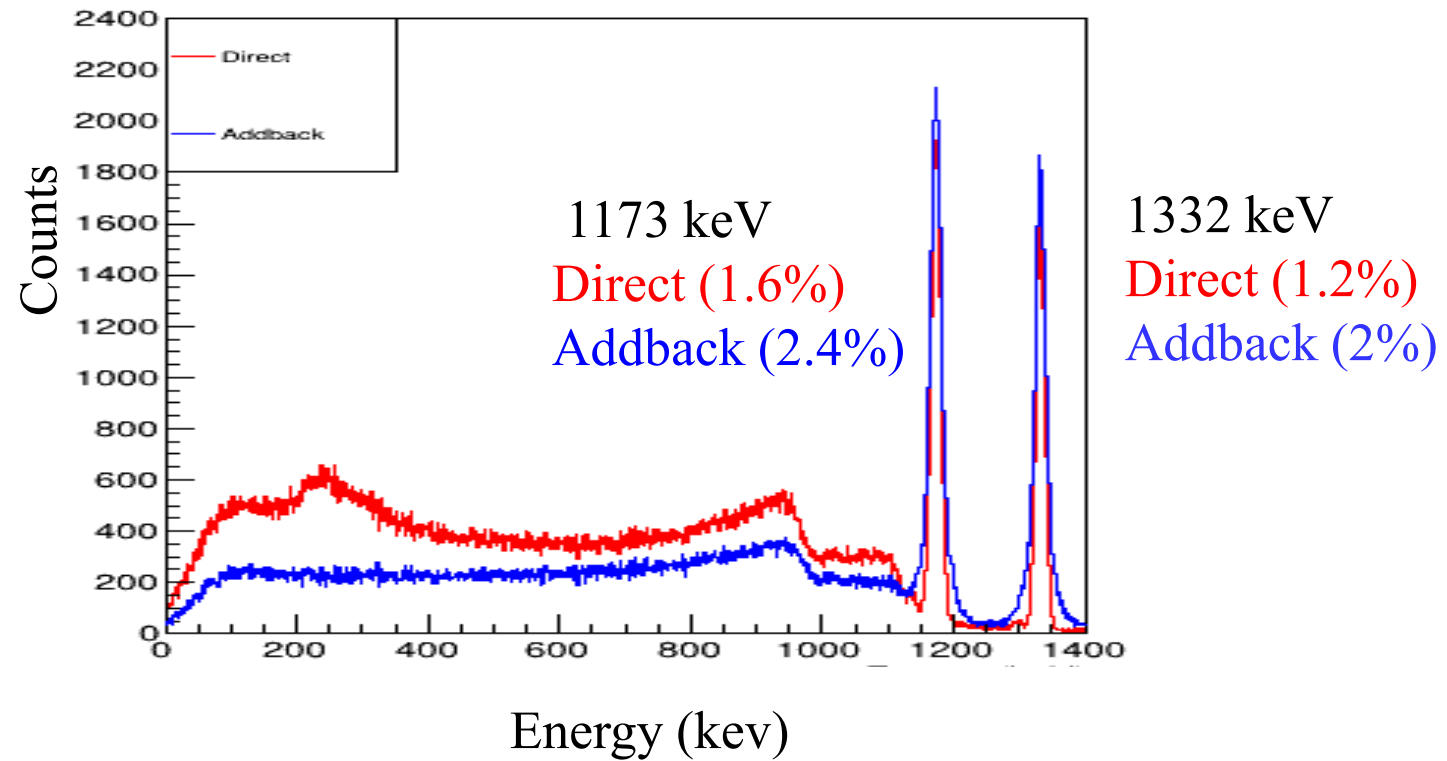

GEANT4 Simulation results for Cs and Co sources

Initial Simulation Validation

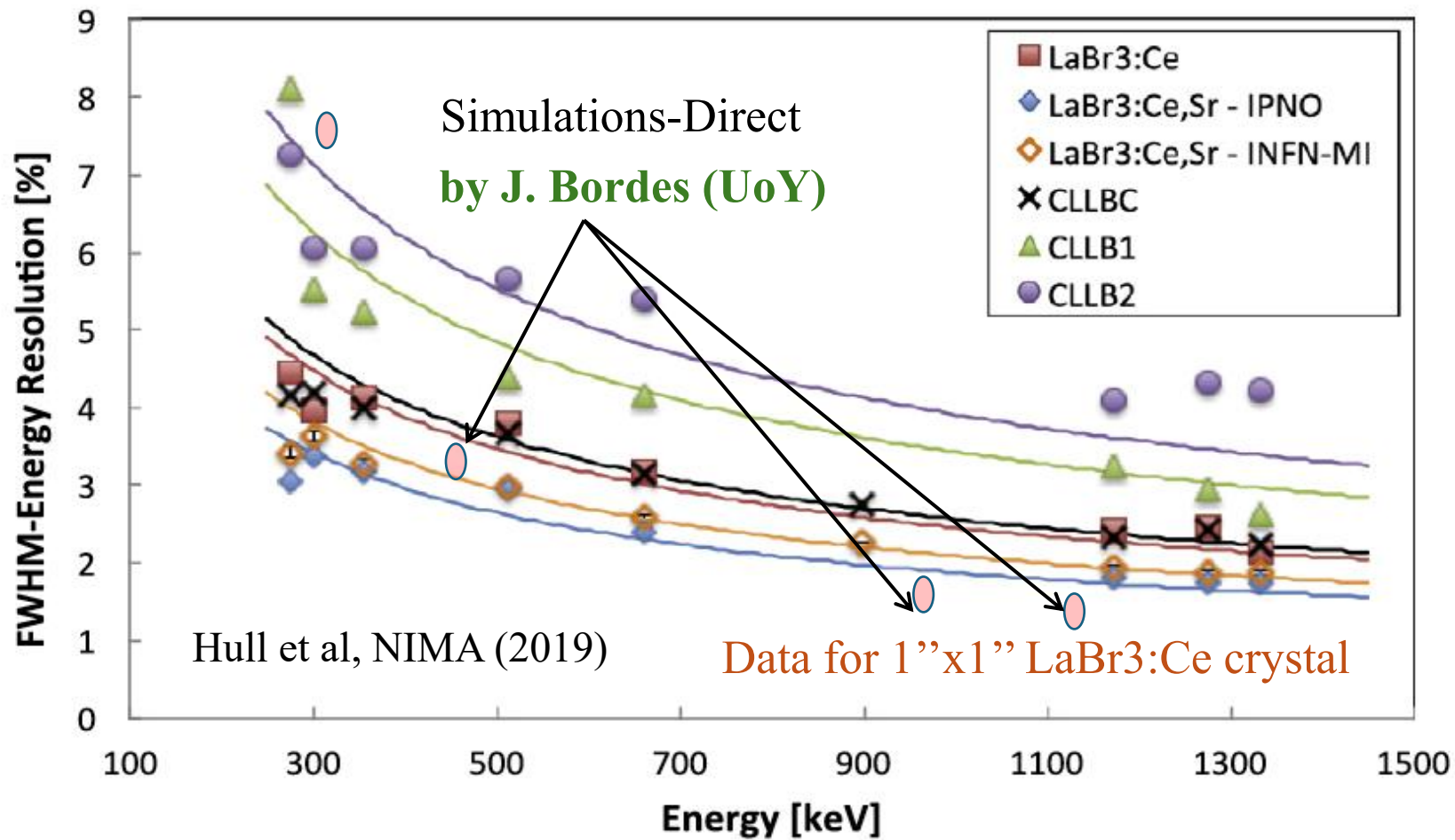

Clover Detector Prototype Construction

Glove box at the University of York



Assembling the Clover detector

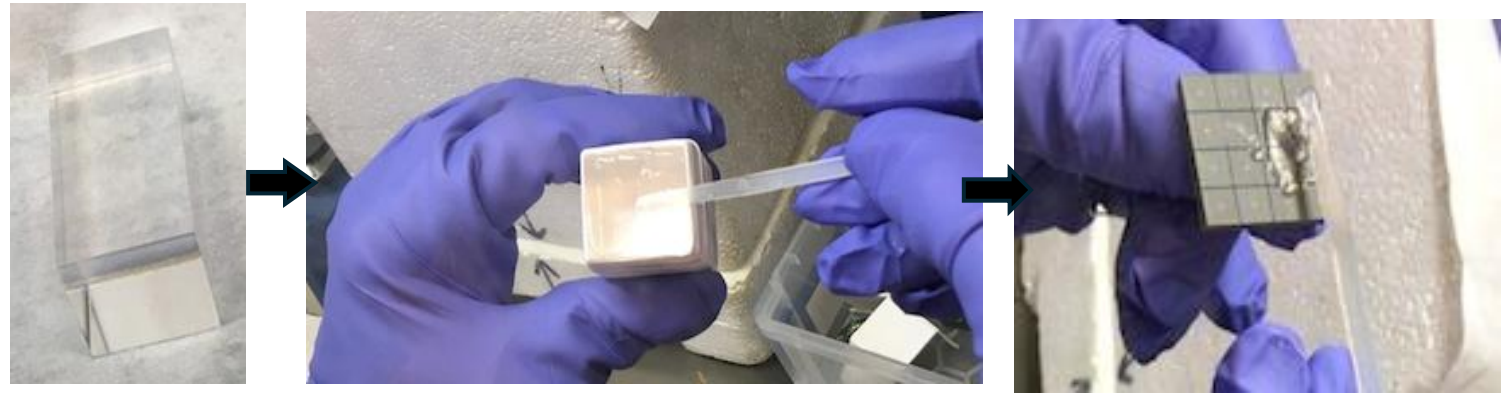

Glove Box at UWS

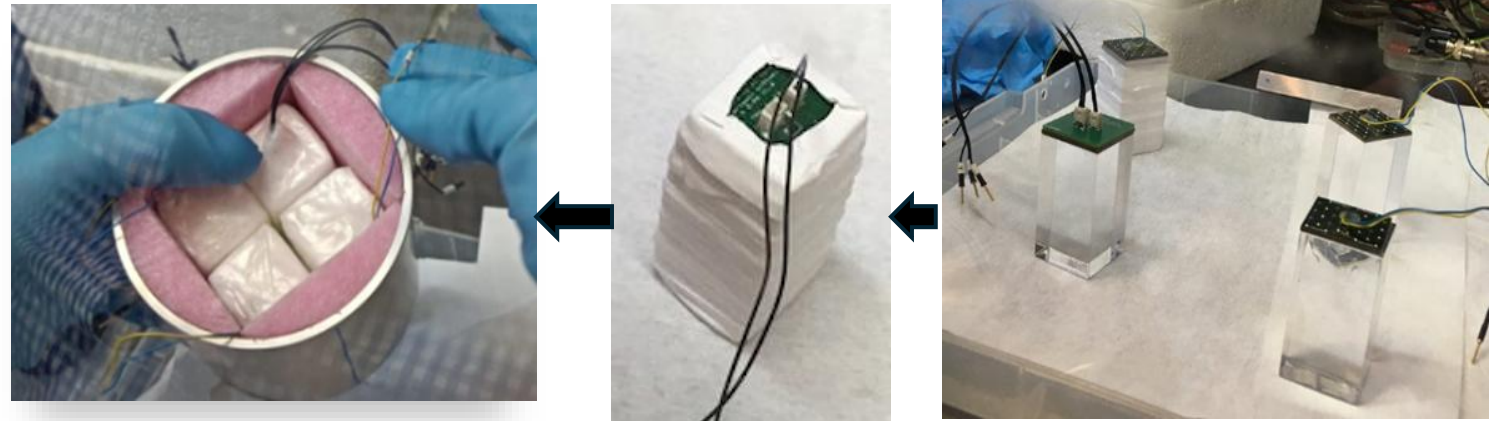
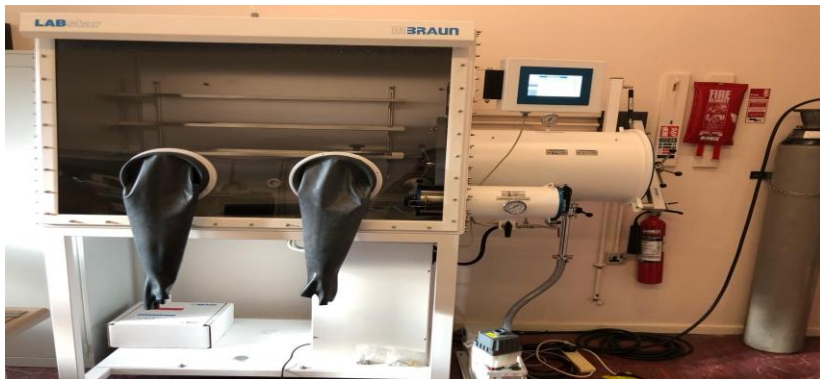

Tests of individual crystals - Preliminary results

Standard construction with PMT FWHM $\sim 3.2\%$ at 662 keV

Present construction FWHM $\sim 2.5\%$

Crystal Dim. (inch ³)	Readout	Bias (V)	FWHM (keV)	FWHM (%)
1×1×2	PMT	600	16.6	2.5
1×1×2	YSiPM	40.5	19.0	2.9
1×1×2	HSiPM1	40.5	16.6	2.5
1×1×2	HSiPM2	40.5	17.9	2.7
1×1×2	HSiPM3	40.5	16.6	2.5

HSiPM & YSiPM readout achieves resolution comparable to PMT

Experimental Setup at University of York

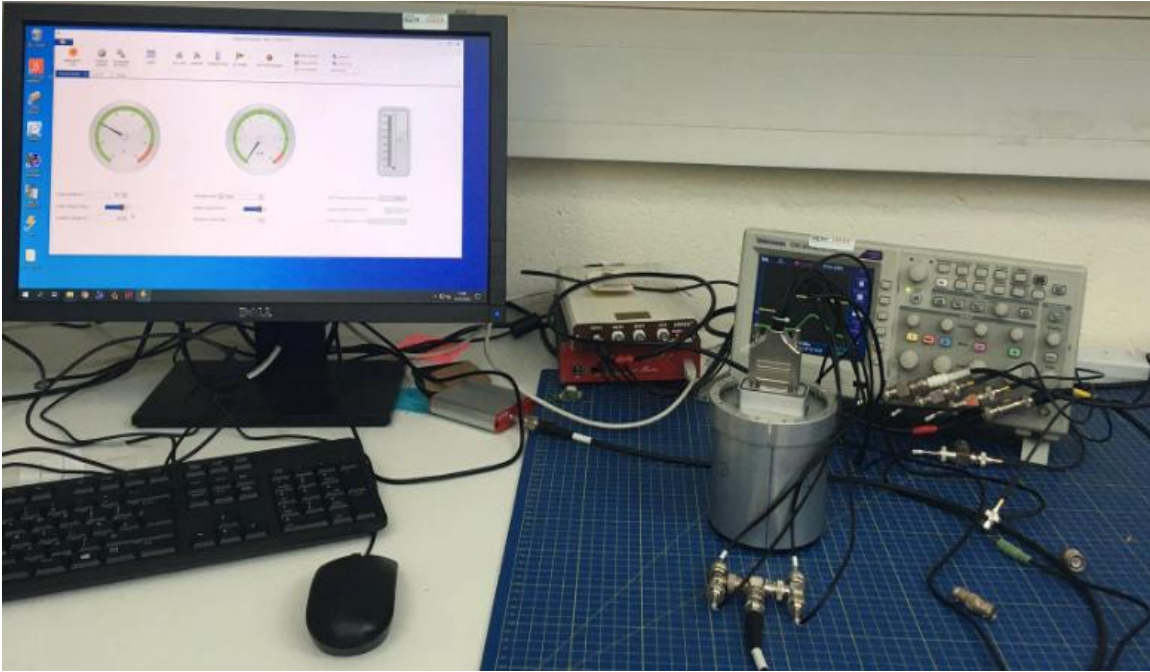
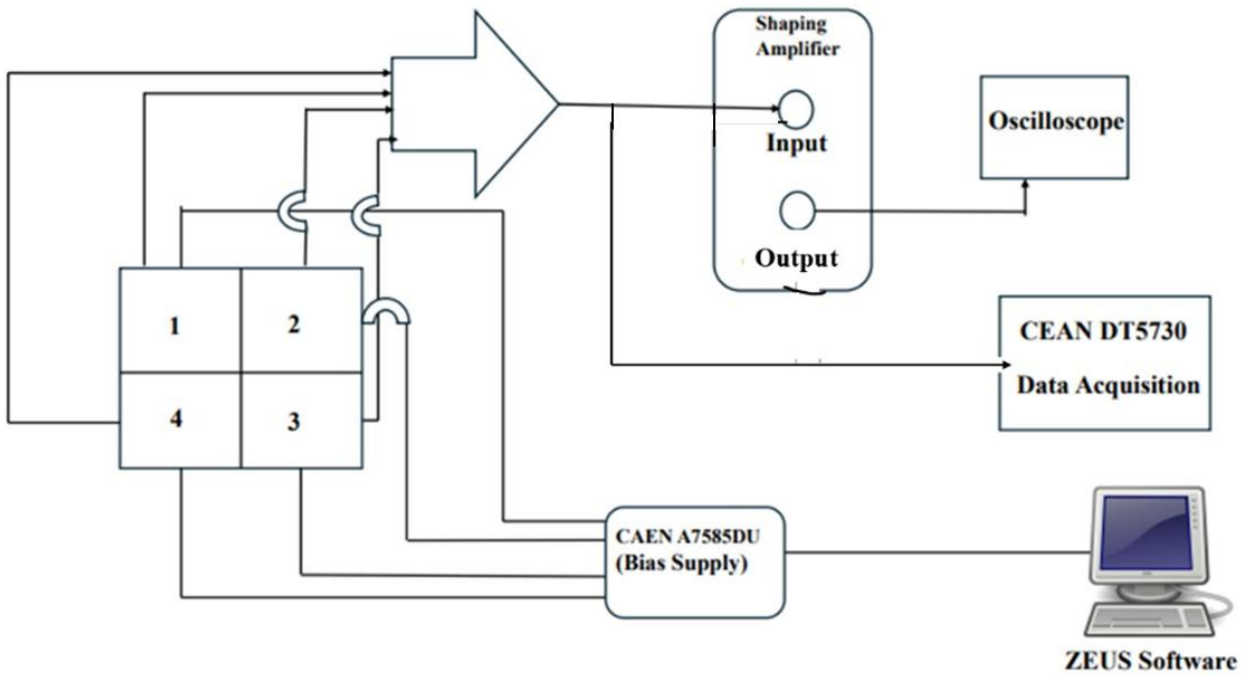

- Bias voltage was 41.9V, and current 0.05mA,
- Experiment was carried out with Cs-137, Co-60, Eu-152 sources

Hit Multiplicity in different Crystals

Single Hit

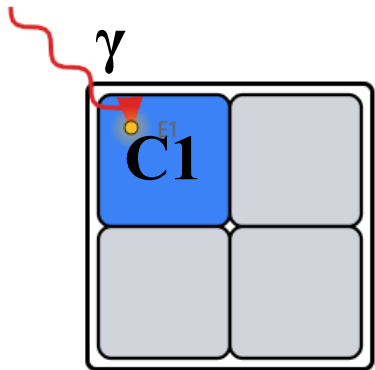

Full energy deposited
in one crystal

Double Hit

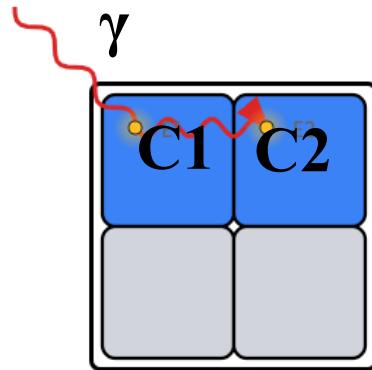

Full energy deposited
in two crystal

Triple Hit

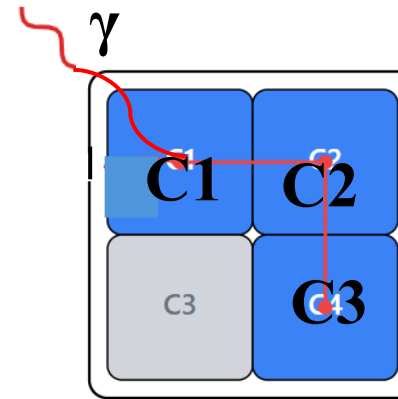

Full energy deposited
in three crystal

Quadruple Hit

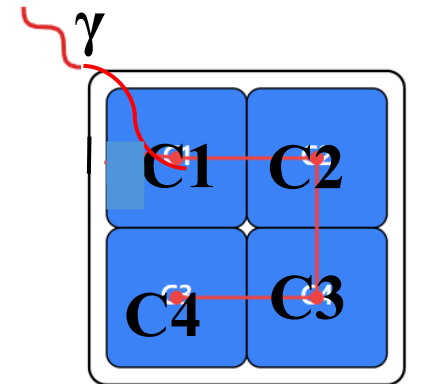

Full energy deposited
in four crystal

Add-back sums coincident energy deposits \rightarrow reconstructs full-energy events

^{137}Cs data for Double Hits & add-Back

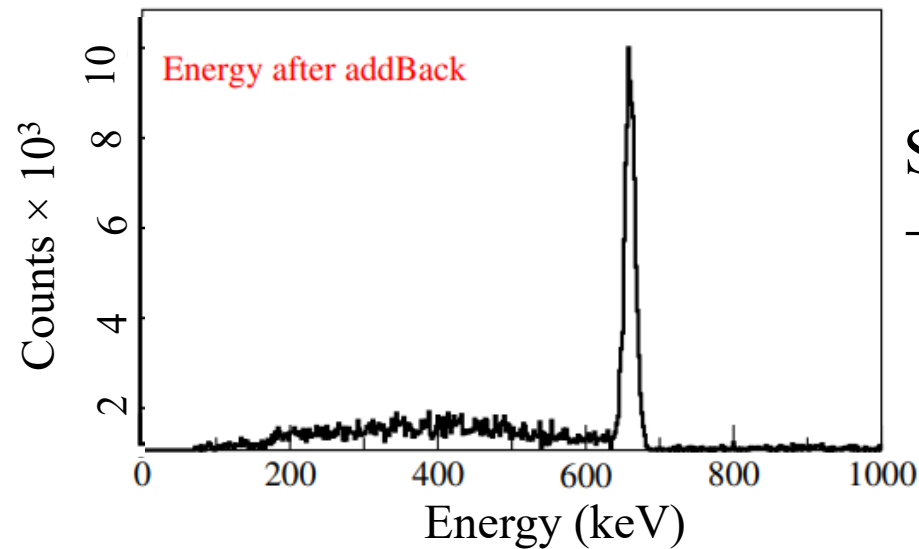
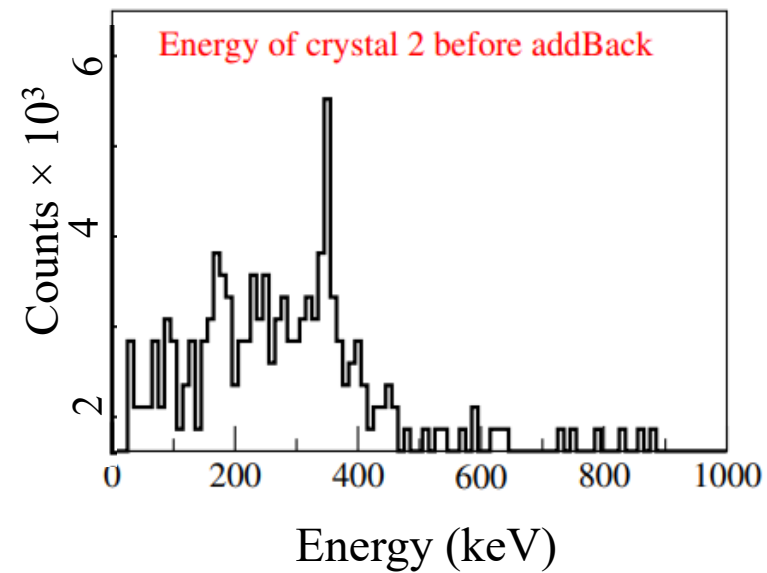
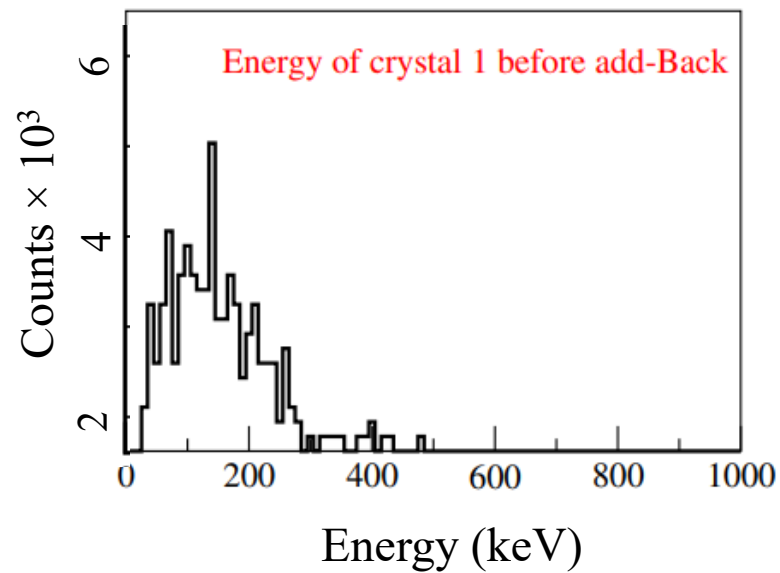

Scattered photon energy added
→ 662 keV photopeak recovered

Crystal Multiplicity in LaBr₃ Clover (¹³⁷Cs)

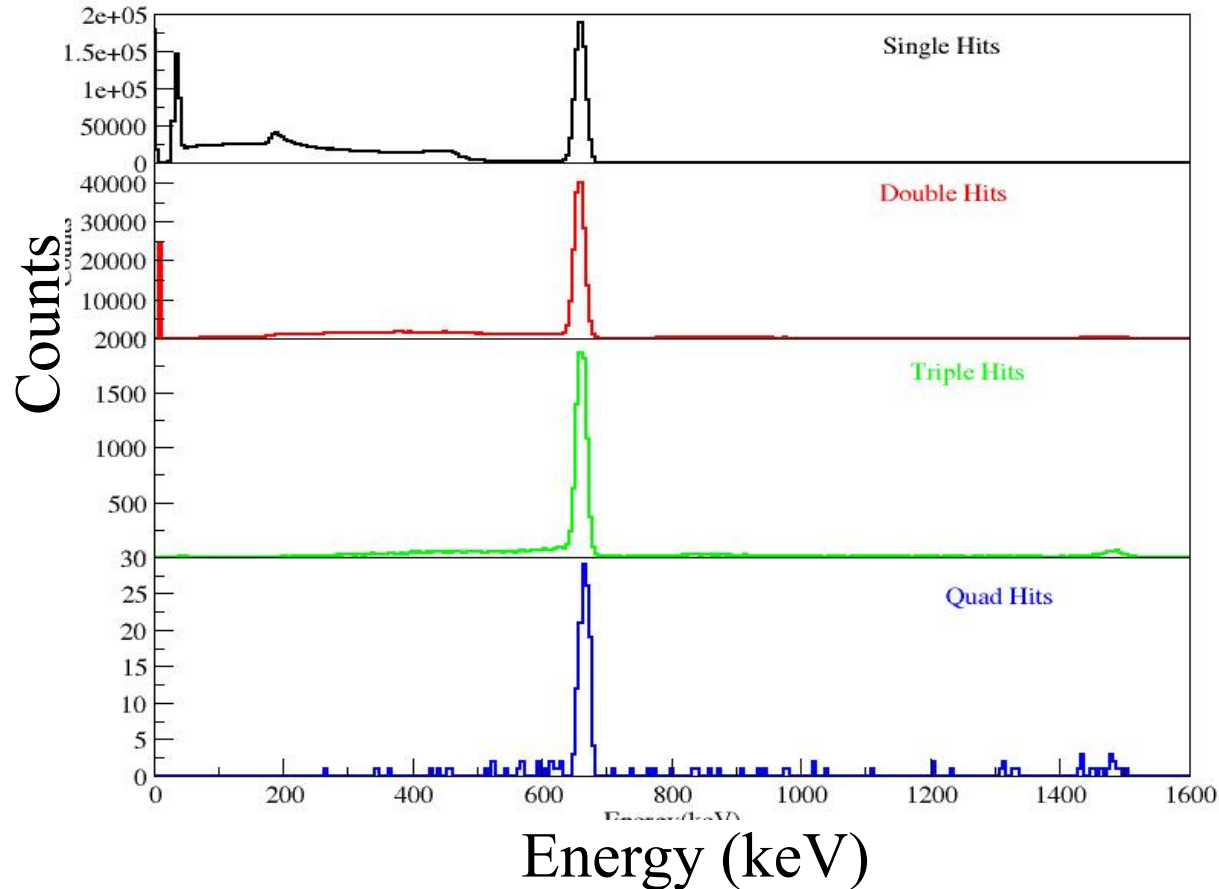

Peak to Total (P/T) Ratio for ¹³⁷Cs

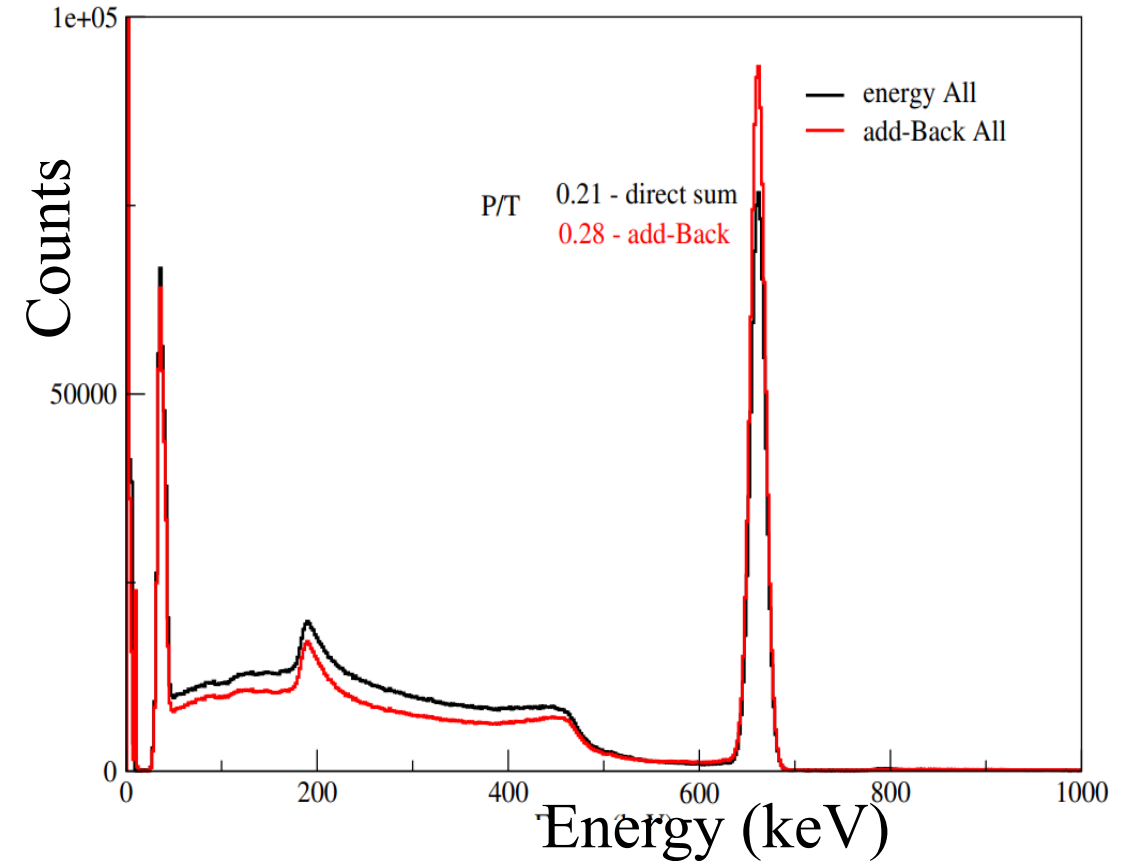

Energy resolution improved from 3.3% (LaBr₃+PMT, Mihai et al., 2020) to **2.9% at 662 keV** using a SiPM-based LaBr₃ clover detector.

^{60}Co data for Double Hits & add-Back

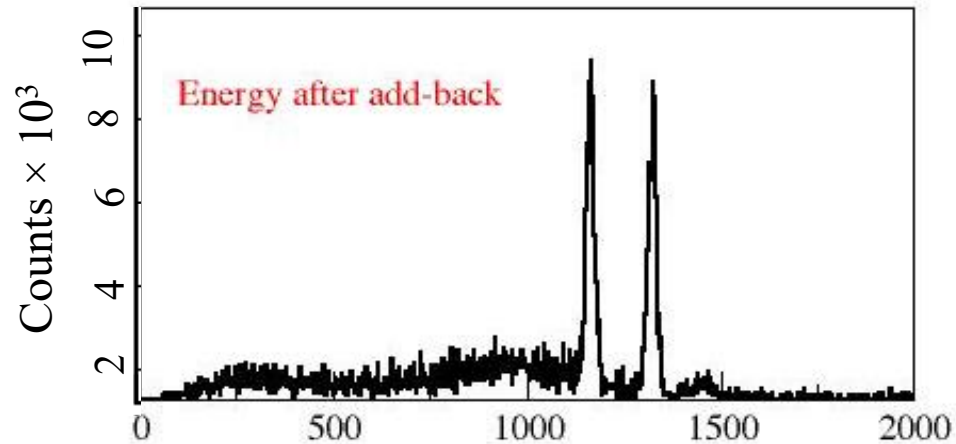
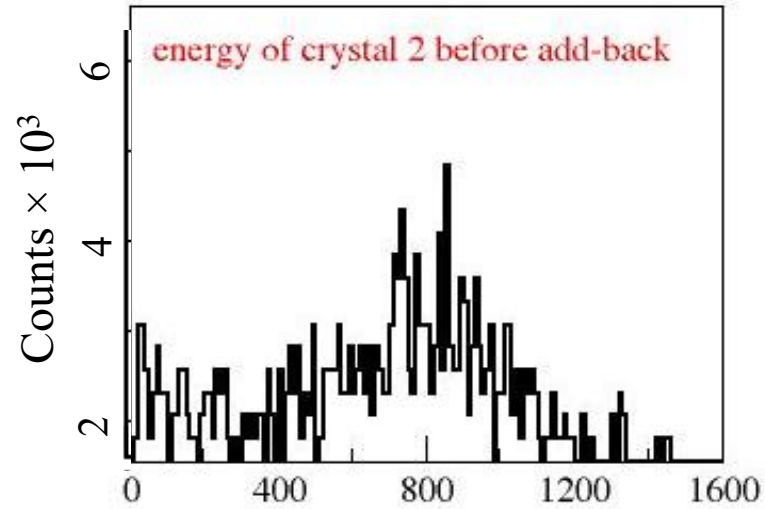
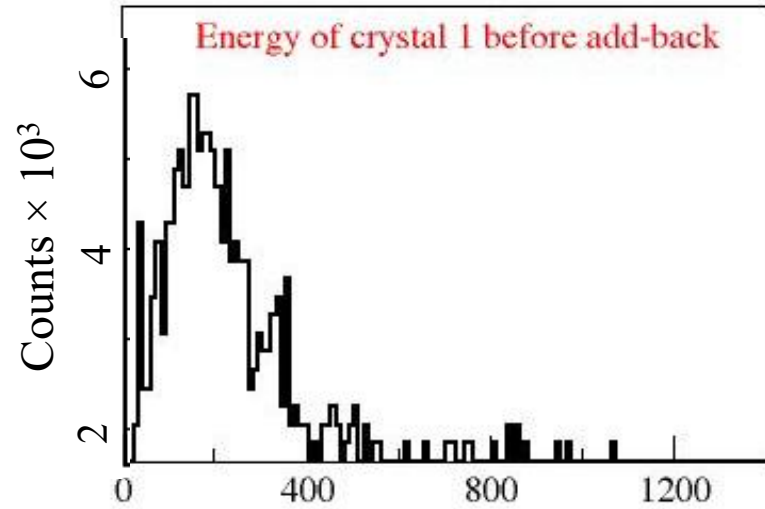

Scattered photon energy added
→ 1173, 1332 keV photopeak recovered

Crystal Multiplicity in LaBr₃ Clover ⁶⁰Co

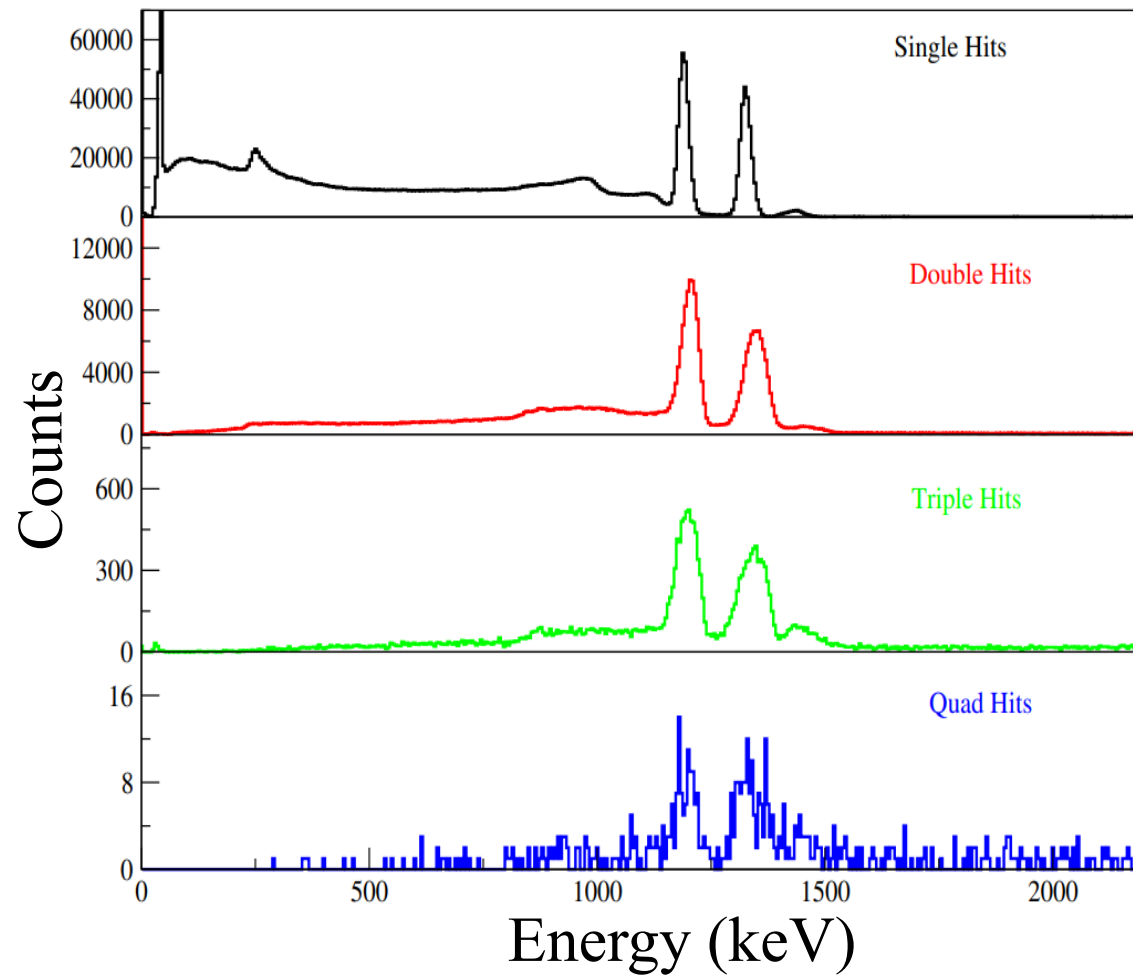

Peak to Total (P/T) Ratio for ⁶⁰Co

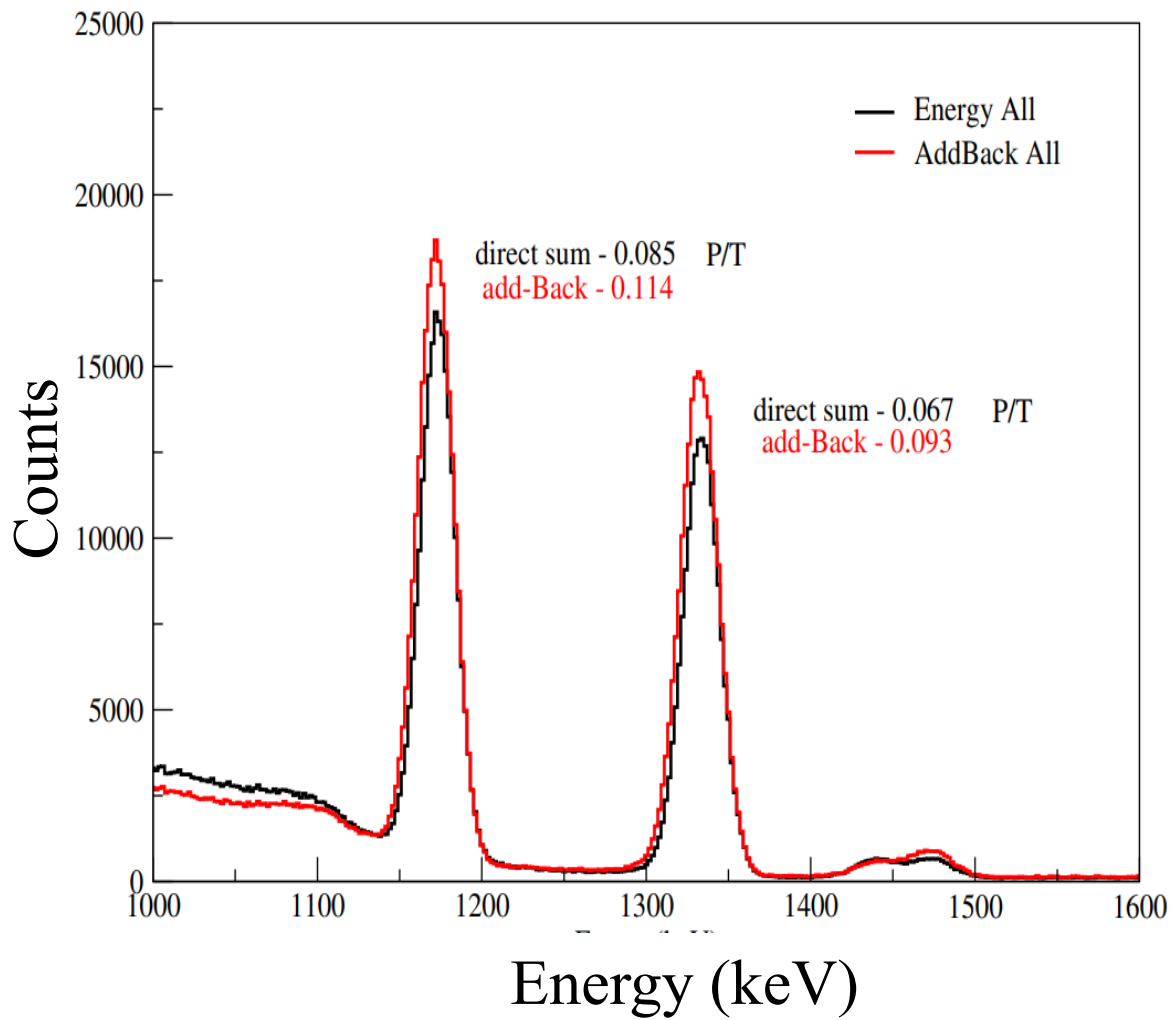

Add-back improves P/T at both 1173 and 1332 keV

Single, Double, Triple & Quadrupole Hits of ^{152}Eu

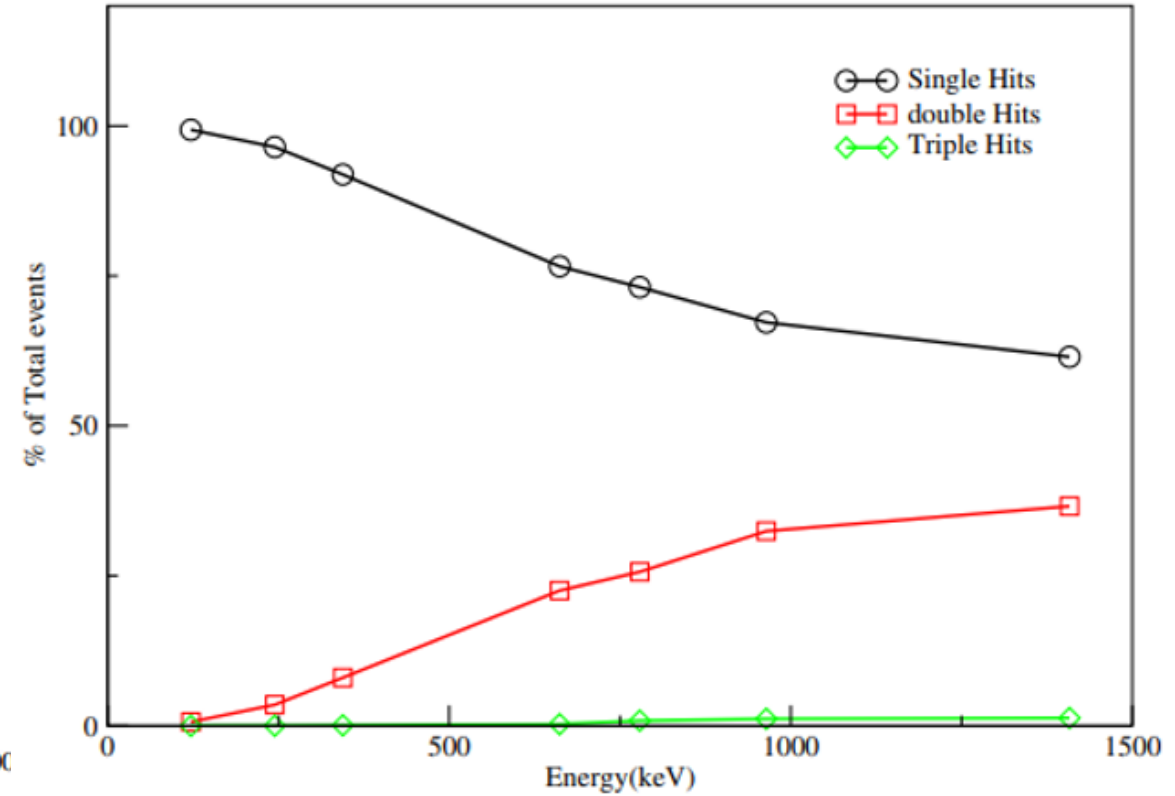
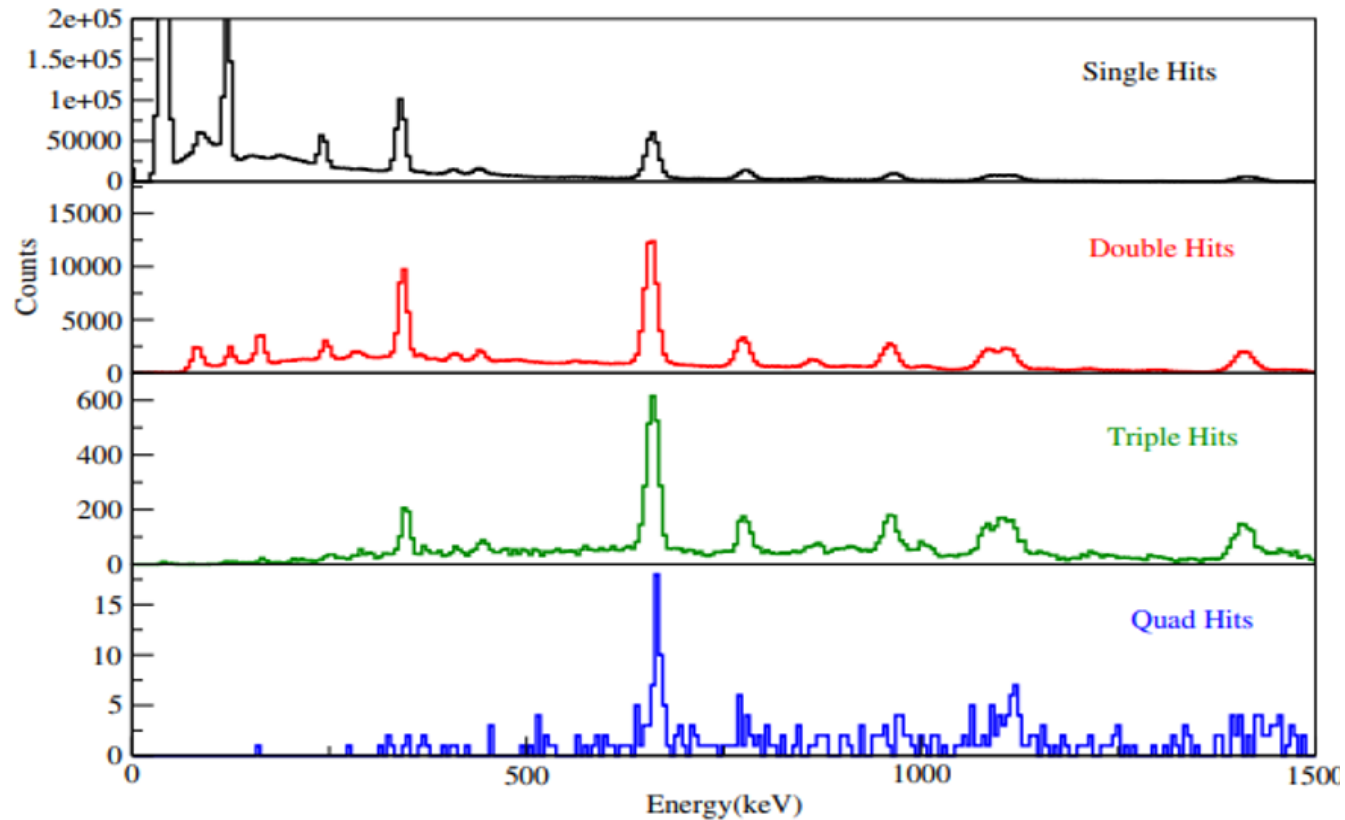

At higher energies, increasing double-hit fraction makes add-back increasingly important.

FWHM of source data with and without add-Back

Energy	FWHM without add-Back	FWHM with add-Back
121.7	9.8(6)	9.8(6)
244.6	15.1(2)	15.5(4)
344.2	17.3(1)	17.5(2)
662.6	18.9(3)	18.9(8)
778.9	21.3(1)	21.4(8)
964.1	23.0(5)	23.3(4)
1173.2	26.7(6)	27.0(6)
1332.5	27.7(6)	29.2(6)

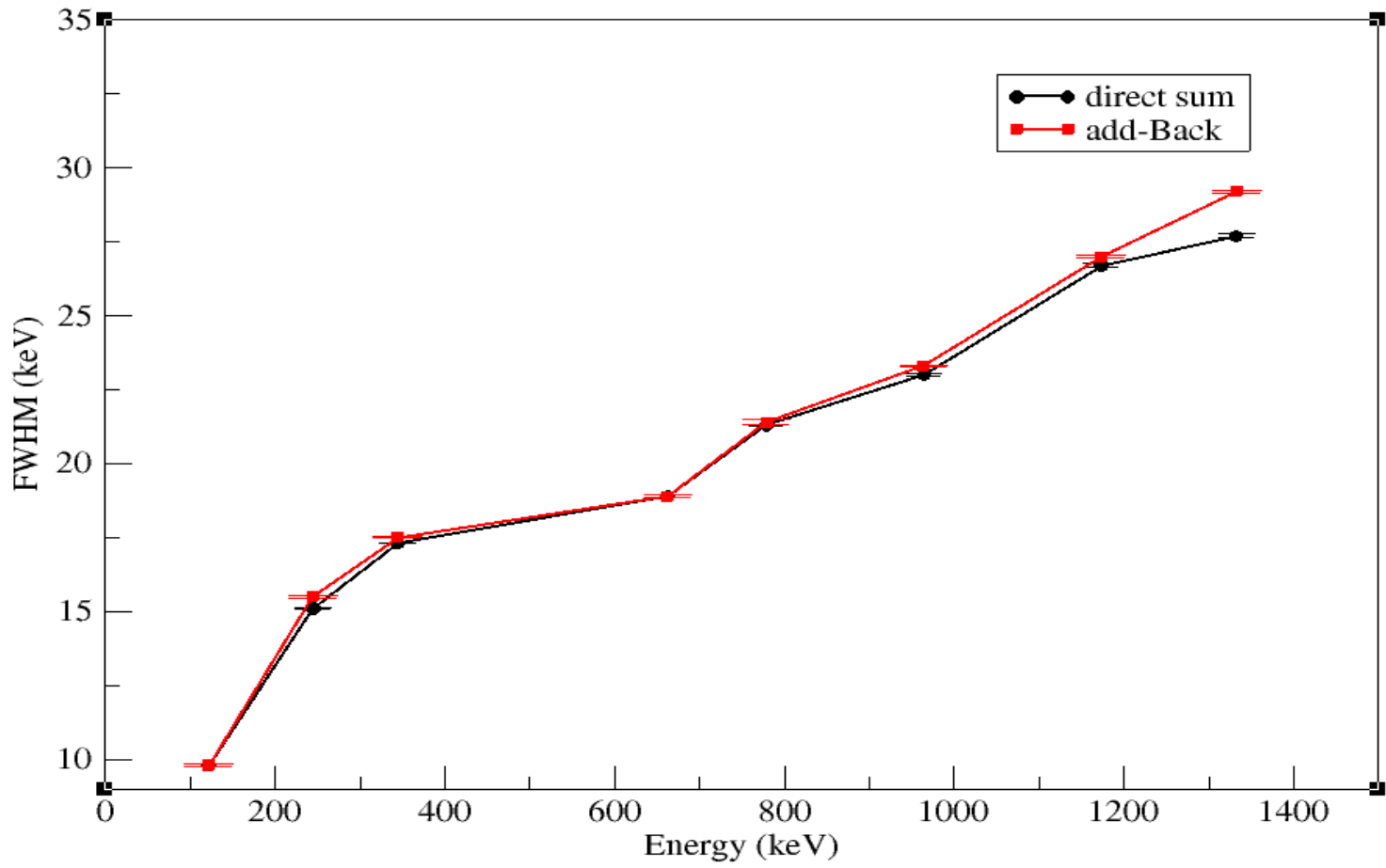

Resolution preserved across all energies - add-back improves P/T without degrading FWHM

Beam experiment performed at CMAM Laboratory, Madrid, March 2025

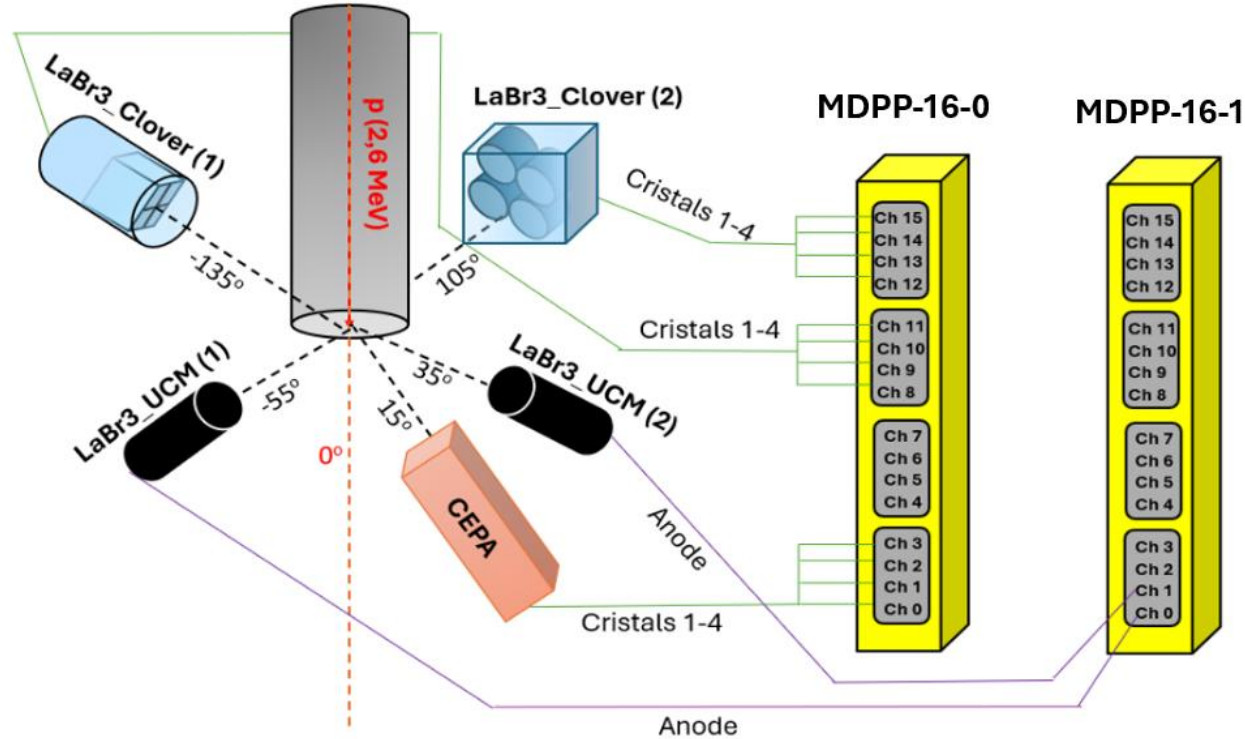

Purpose: Evaluate detector performance and acquire **prompt γ -ray data from astrophysical and nuclear structure reactions**

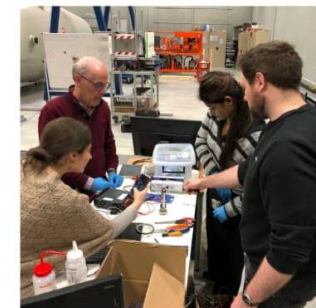
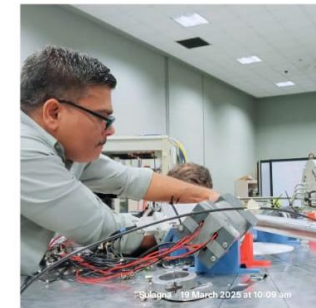
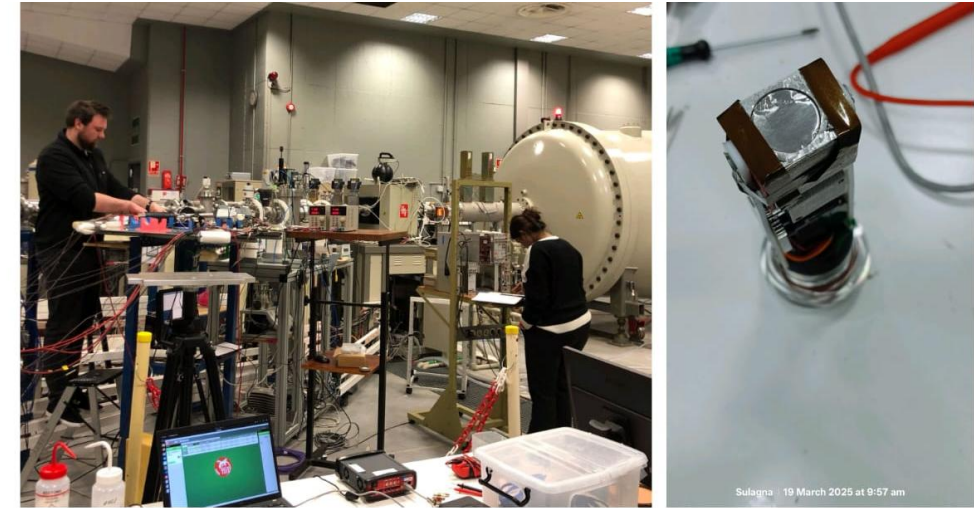

$^{19}\text{F}(p,\alpha)^{16}\text{O}$ Reaction - Comparison with CSIC Simulation

LaBr3 spectrum

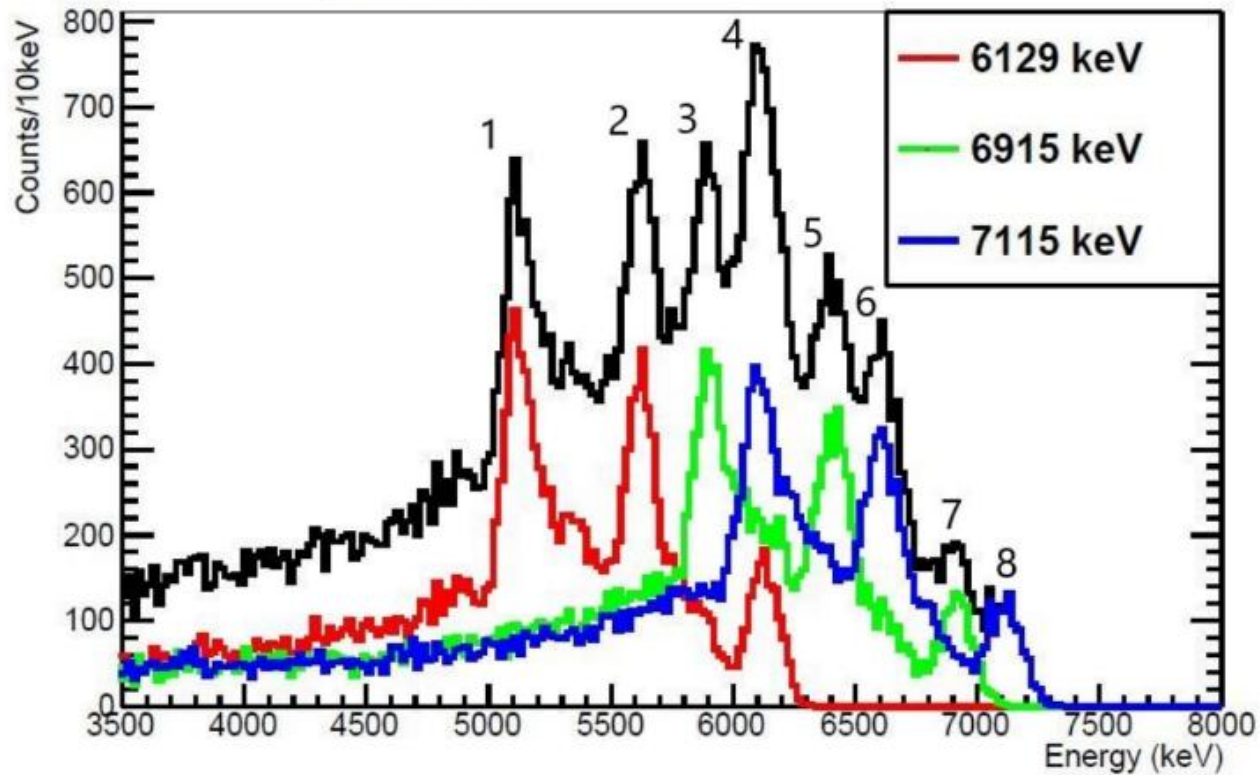

Peak	1	2	3	4	5	6	7	8
Energy (keV)	5106.6	5617.6	5893.5	6093.2	6128.6	6404.5	6604.2	7115.2

GEANT simulation - CSIC

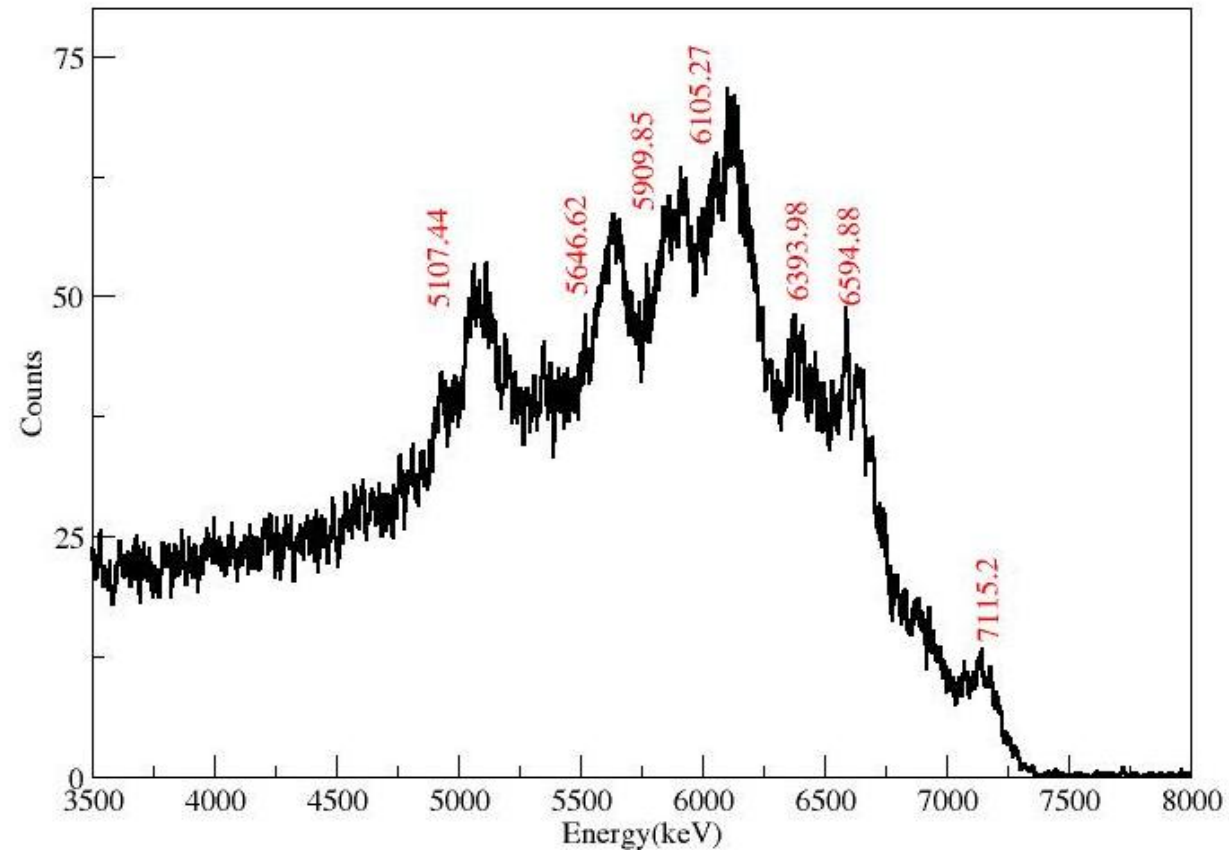

Measured LaBr₃ spectrum
CMAM Experiment

Timing Performance Studies of the LaBr₃ Clover Detector with ⁶⁰Co source (UWS)

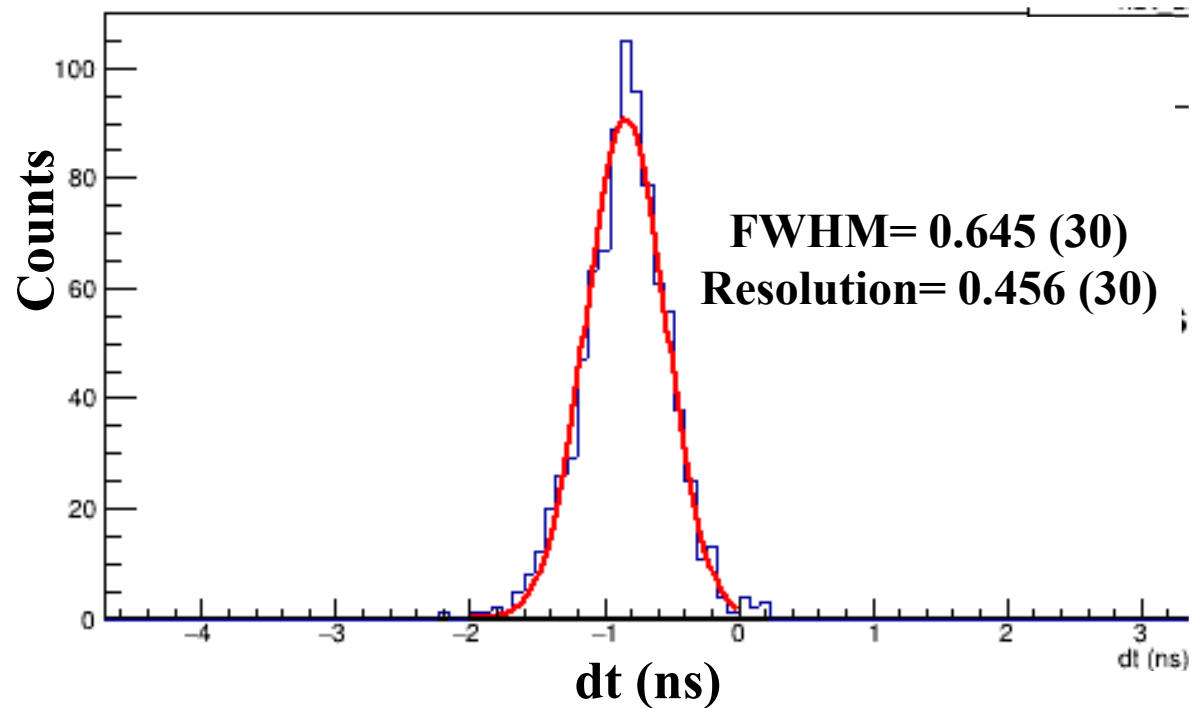
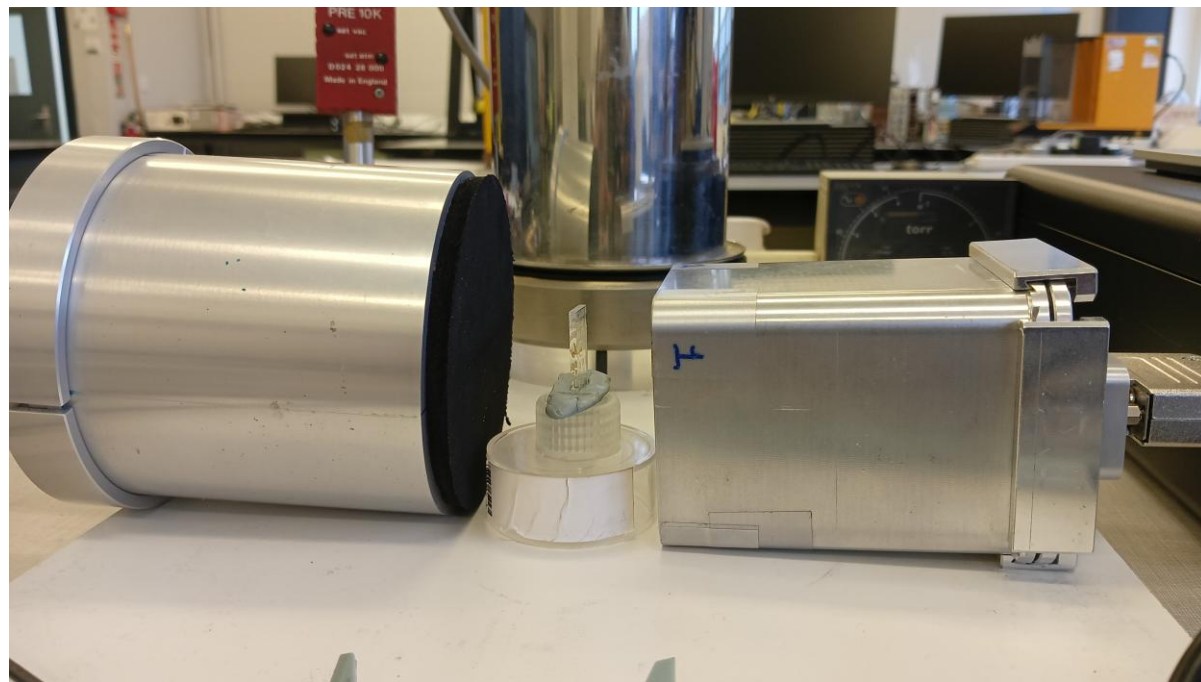

Sub-nanosecond timing resolution (FWHM \approx 0.65 ns)

Half-Life Measurement of ^{116m}In (1294 keV γ -line) via Neutron Activation (Am-Be Source)

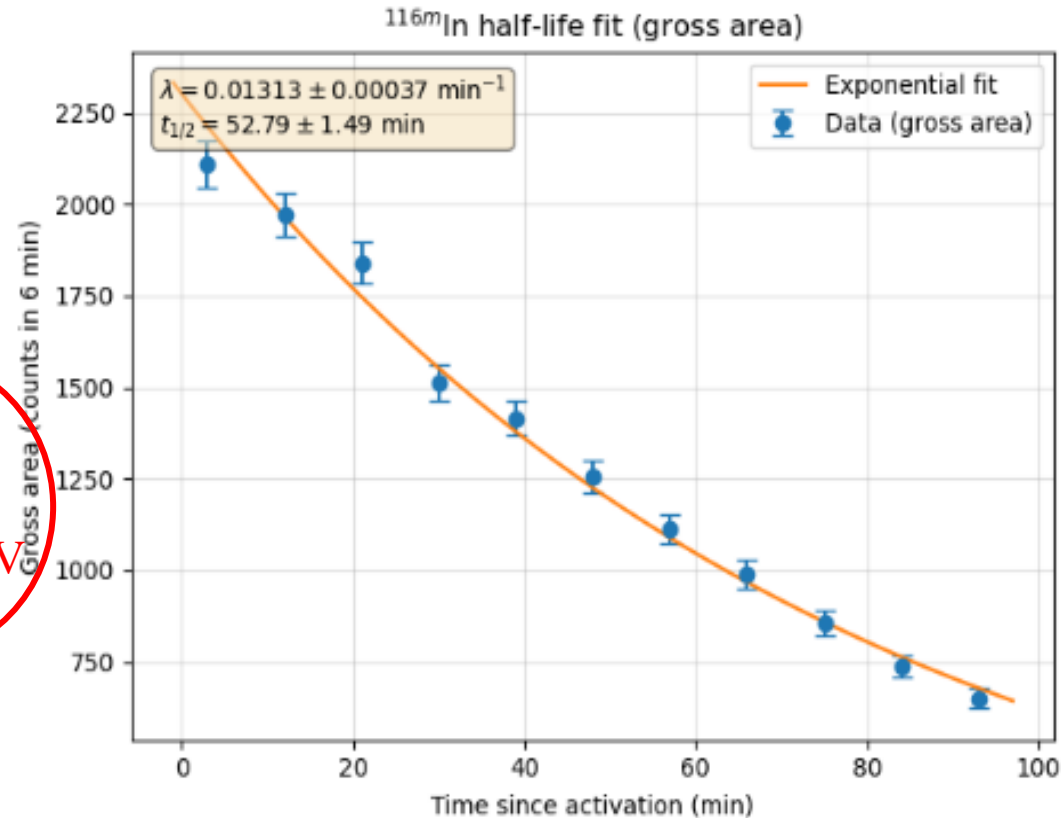
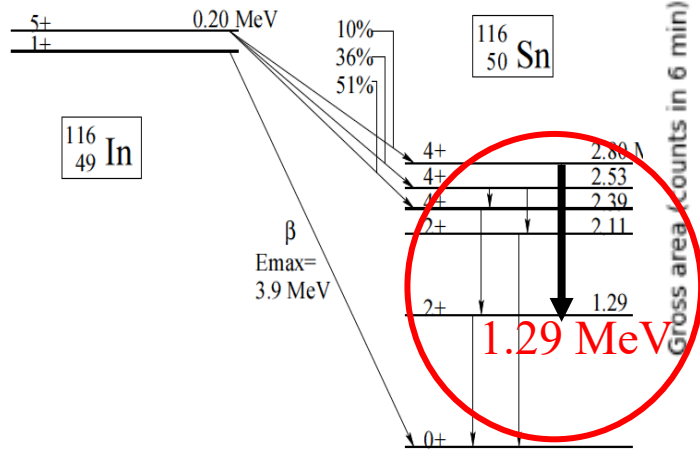

$$\lambda = (0.01313 \pm 0.00037) \text{ min}^{-1} \quad T_{1/2} = (52.79 \pm 1.49) \text{ min.}$$

The Herald

Subscribe

News Politics Sport

News Scottish News Health Education HQ

Scottish university in 'world-first' for nuclear technology

7TH APRIL 2025 EDUCATION



The team at the University of the West of Scotland (Image: UWS)

Summary & Conclusion

1. Successfully **designed and constructed** a compact $\text{LaBr}_3(\text{Ce})$ -SiPM **clover detector** prototype.
2. Demonstrated **good energy resolution** (2.9 % at 662 keV) and **stable performance** across all crystals.
3. **Addback method** improved peak-to-total ratio and enhanced weak γ -ray detection.
4. Performed **beamline validation** at CMAM (Madrid) using multiple **astrophysically relevant reactions**. (e.g. ${}^4\text{He}({}^3\text{He},\gamma){}^7\text{Be}$, ${}^{12}\text{C}({}^3\text{He},\gamma){}^{15}\text{O}$, ${}^{27}\text{Al}({}^3\text{He},\alpha){}^{26}\text{Al}$, ${}^{19}\text{F}(\text{p},\alpha){}^{16}\text{O}$).
5. Observed γ -rays consistent with **simulations and published data**, confirming detector accuracy.
6. Conducted **timing measurements** at UWS with ${}^{60}\text{Co}$, achieving **~ 0.6 ns FWHM** using CFD and LE methods.

Collaboration

C. Cassells, B.S. Nara Singh, M. Bowry, D. O'Donnell, M.Scheck, J.F. Smith

University of the West of Scotland, UK

P. Joshi, J. Bordes, J.R. Brown, D.G. Jenkins

University of York, UK

O. Tengblad, M.J.G. Borge et. al.

Instituto de Estructura de la Materia, CSIC, Spain

J.A.Briz, Luis M Fraile, et. al.

Universidad Complutense de Madrid, Spain

