



B(E2) measurements of heavy N=Z nuclei at FRIB

Mike Bentley, RyoTaniuchi, Bob Wadsworth,
and the **FRIB E21034** collaboration

- Motivation and Background
- E21034 Experiment at FRIB
- New results
- 2^+ lifetime, hence $B(E2) 2^+ \rightarrow 0^+$ in $N=Z$ ^{88}Ru
- New shell-model approach



FRIB

Motivation: ^{88}Ru



UNIVERSITY
of York

$A \sim 80$ $N=Z$:

- Highest deformation/collectivity
- Shape Mixing and co-existence
- Pseudo- and quasi-SU(3) valence space
- How (and why) does collectivity develop?

HFB calculations:

*J. P. Delaroche, et al.,
PRC81,014303 (2010)*

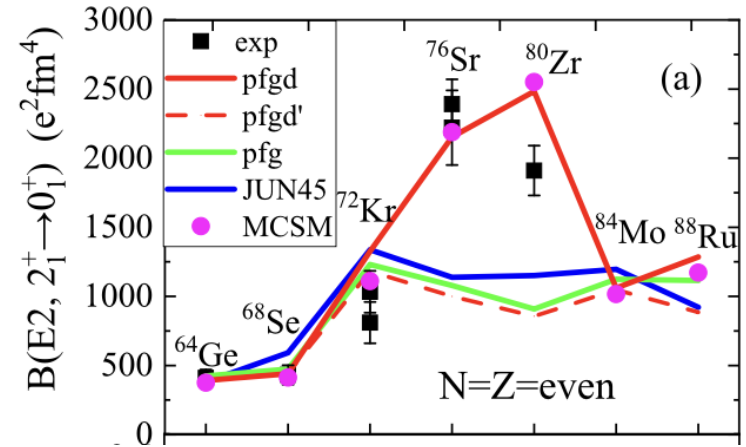
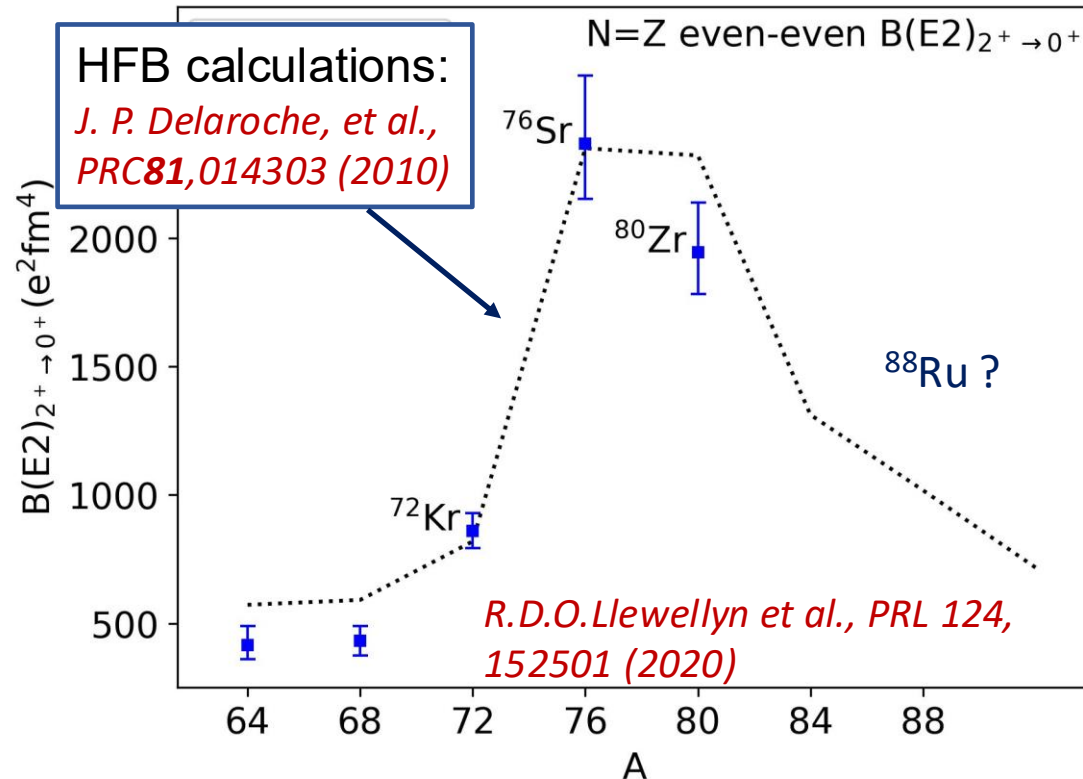

*Kaneko et al. Physics Letters B
817 (2021) 136286*

Challenges for shell-model

- Large valence space (incl ds orbitals)
- New interactions (e.g. ZBM3)
- New approaches (e.g. DNO-SM calculations)

Experiment 21034: April 2023

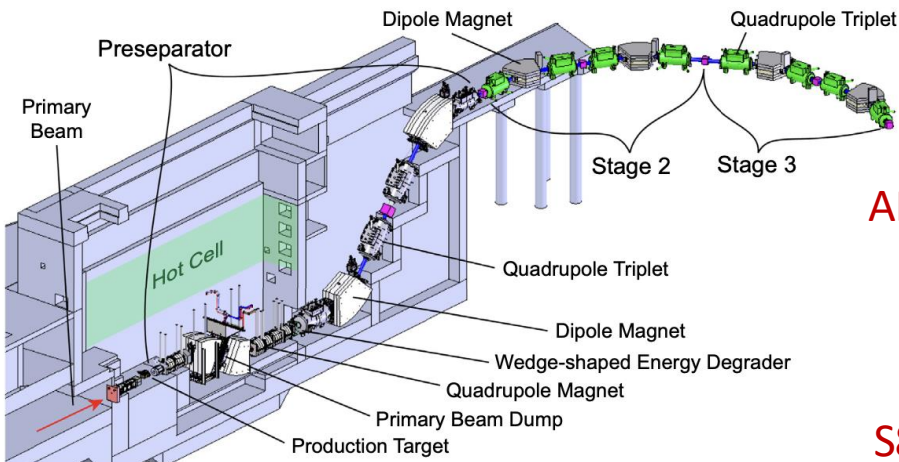

ARIS Separator

Primary beam: ^{124}Xe
227 MeV/u 5kW



Secondary beams:
 ^{89}Ru (~100-150 pps)
 ^{88}Tc (~3000 pps)

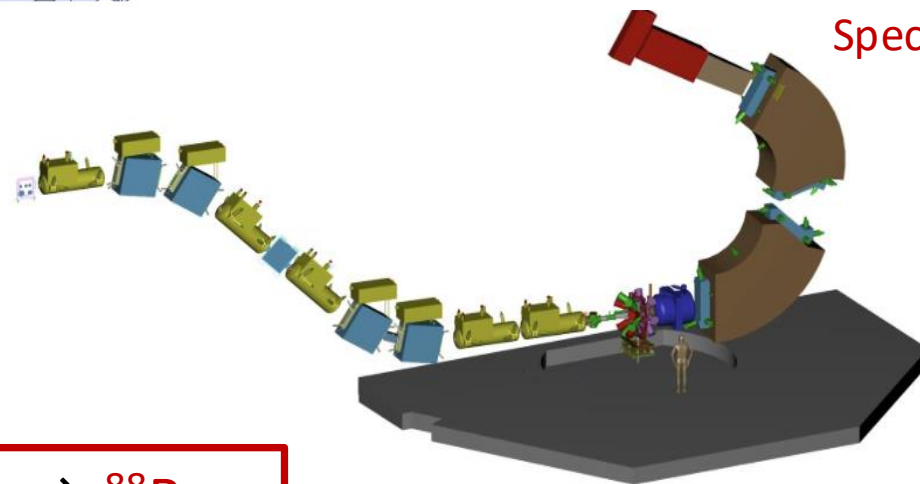

S800
Spectrograph



^{89}Ru purity 0.04% !!

E21034: April 2023

Gretina – 12 quads (48 crystals)

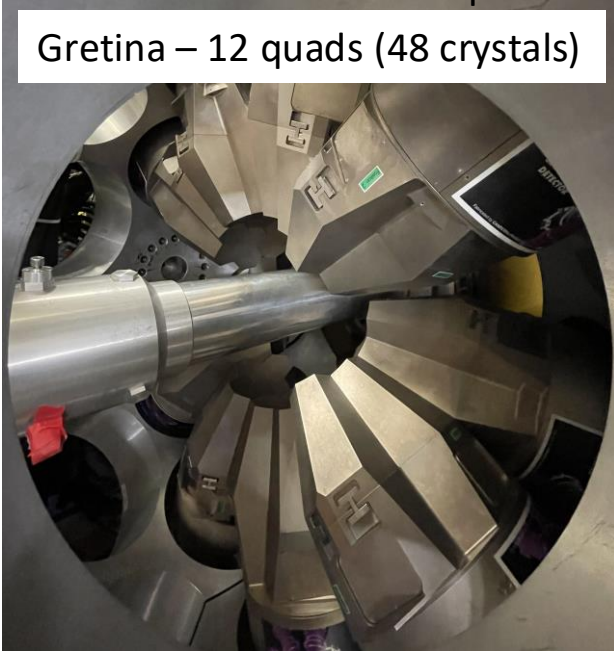

TRIPLEX PLUNGER

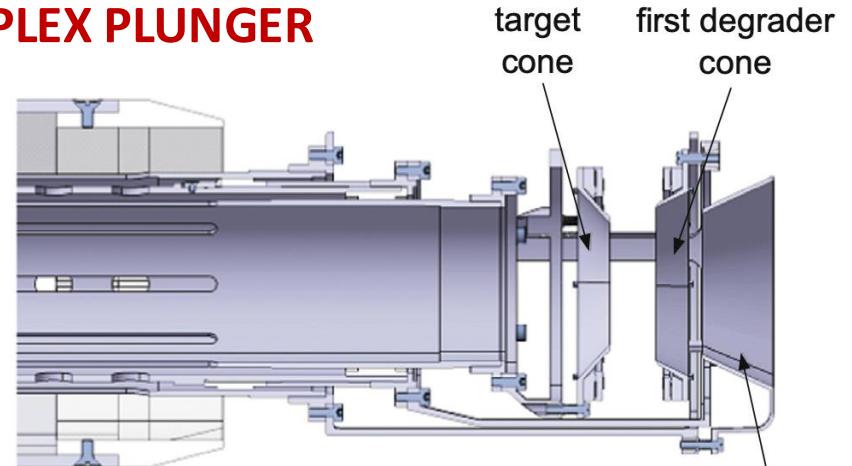

Iwasaki et al., NIMA 806 (2016) 123–131

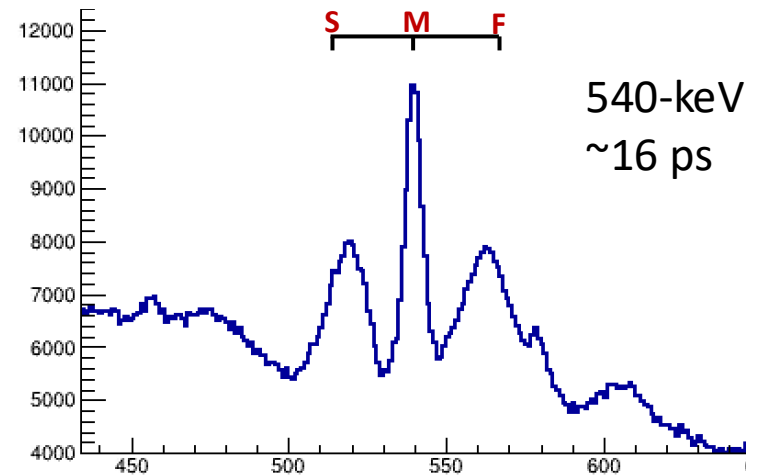
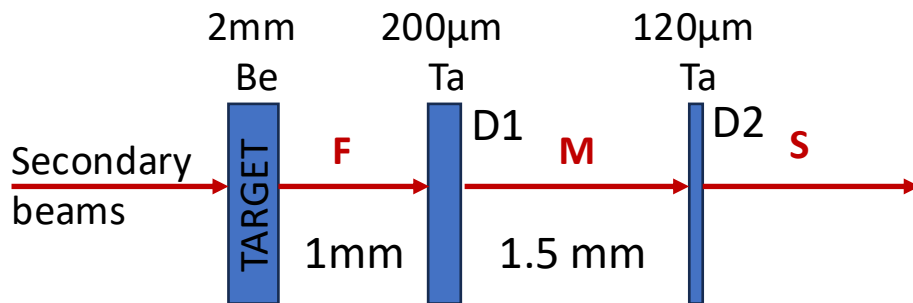

Experiment: Reactions and PID

^{88}Ru (-1n knockout)

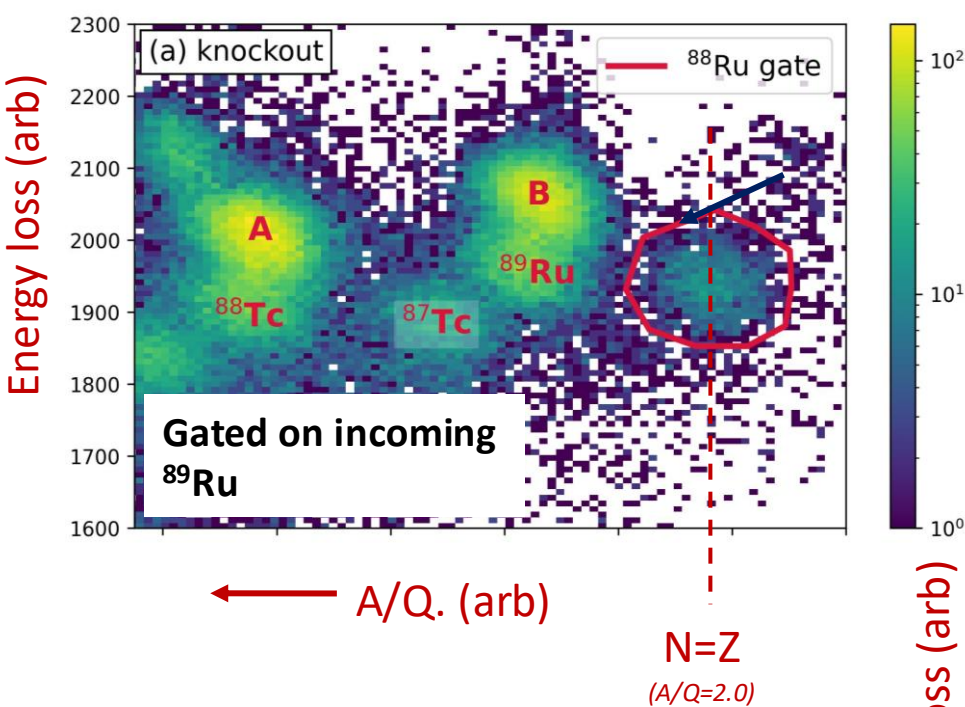

^{88}Ru (charge exchange!)

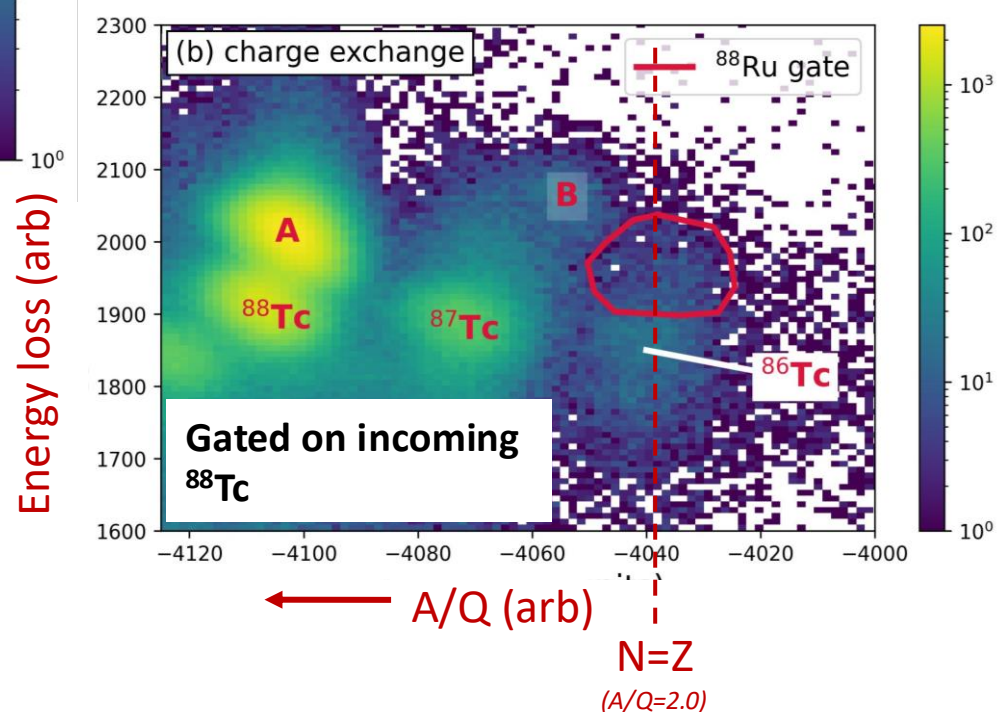



(14)

(1253)

12⁺ 5696

1153

10⁺ 4543

1063

8⁺ 3480

1100

6⁺ 2380

964

4⁺ 1416

800

2⁺ 616

616

0⁺ 0

⁸⁸Ru



UNIVERSITY
of York

Counts / 5keV

Counts / 1keV

Counts / 1keV

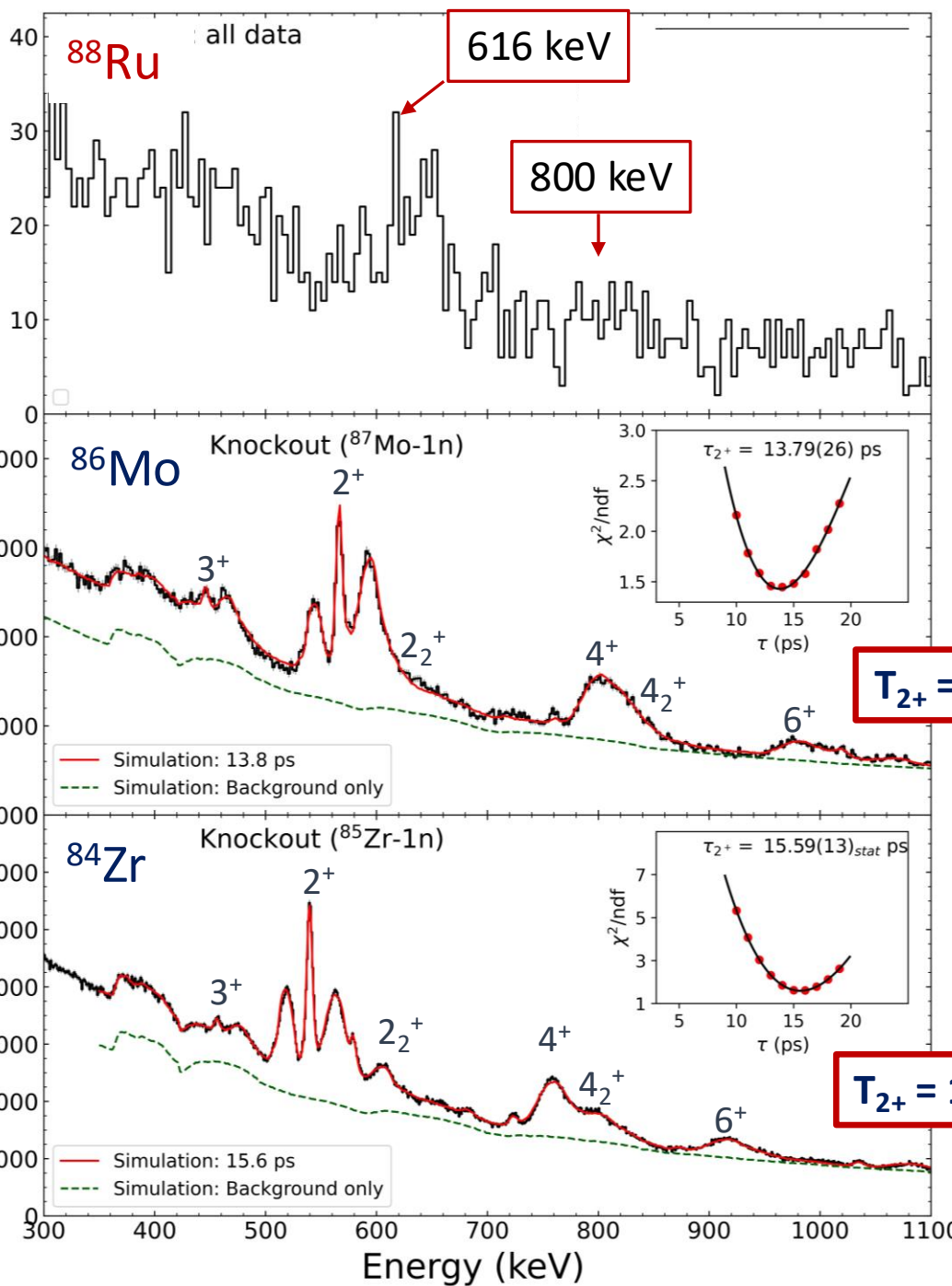

T₂₊ = 13.8(1.0) ps

NEW

T₂₊ = 15.6(1.0) ps

Lit: 20.3(11) ps (!!)

N=44 isotones

Cederwall et al.,
PRL 124,
062501 (2020)

M. A. Bentley et al. Phys. Rev. Lett. (2026) – in press

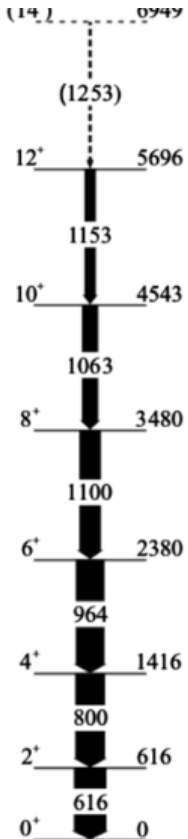

^{88}Ru

*Cederwall et al.,
PRL 124,
062501 (2020)*

Counts / 5keV

Counts / 1keV

Counts / 1keV

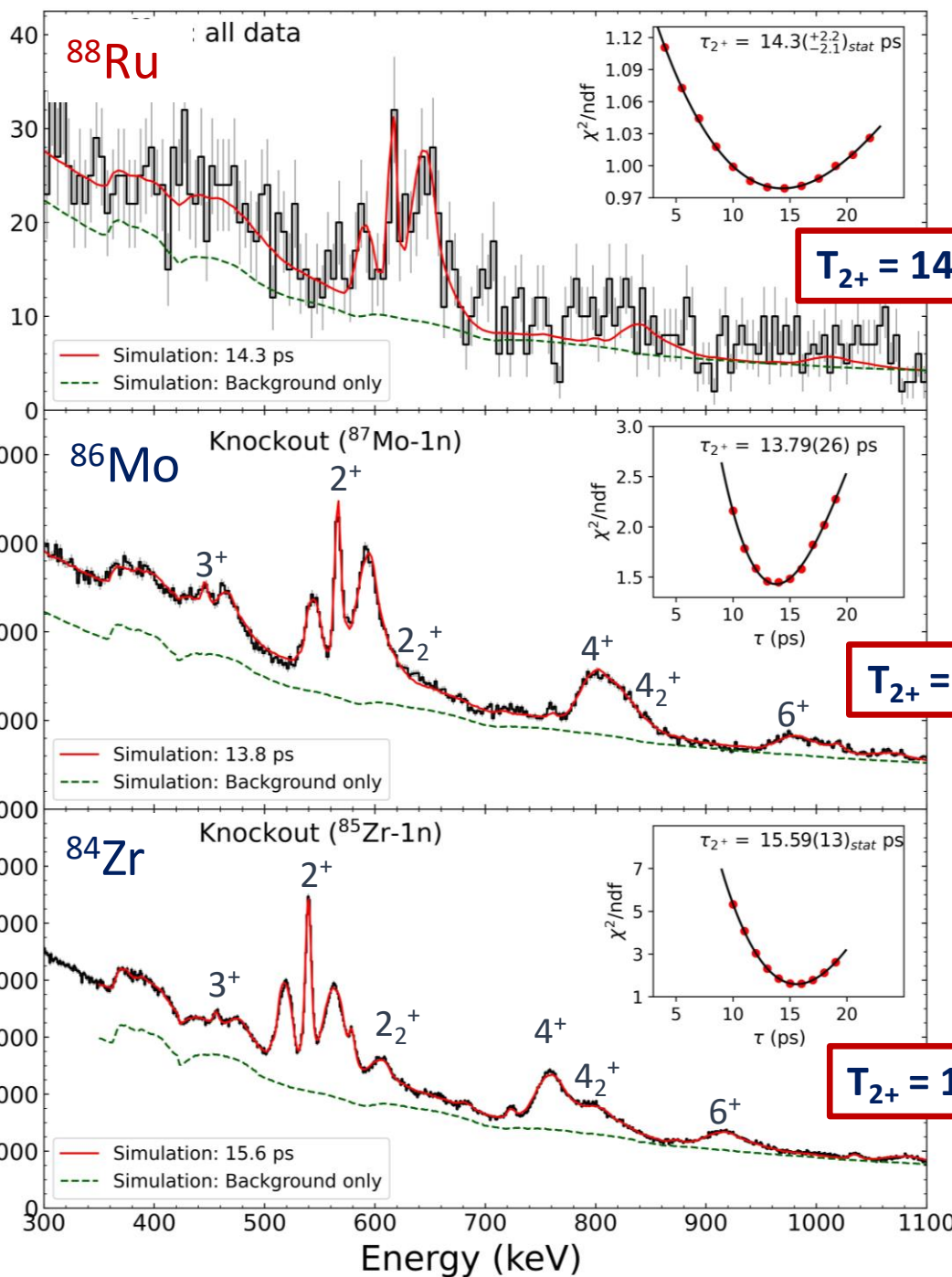

UNIVERSITY
of York

NEW

$$\tau_{2^+} = 14.3^{+2.5}_{-3.4} \text{ ps}$$

$$B(E2) (2^+ \rightarrow 0^+) = 640^{+200}_{-100} \text{ e}^2\text{fm}^4$$

$$\tau_{2^+} = 13.8(1.0) \text{ ps}$$

NEW

$$\tau_{2^+} = 15.6(1.0) \text{ ps}$$

Lit: 20.3(11) ps (!!)

M. A. Bentley et al. Phys. Rev. Lett. (2026) – in press

Maximum Likelihood Fits



Knockout
from ^{89}Ru

Charge
Exchange
from ^{88}Tc

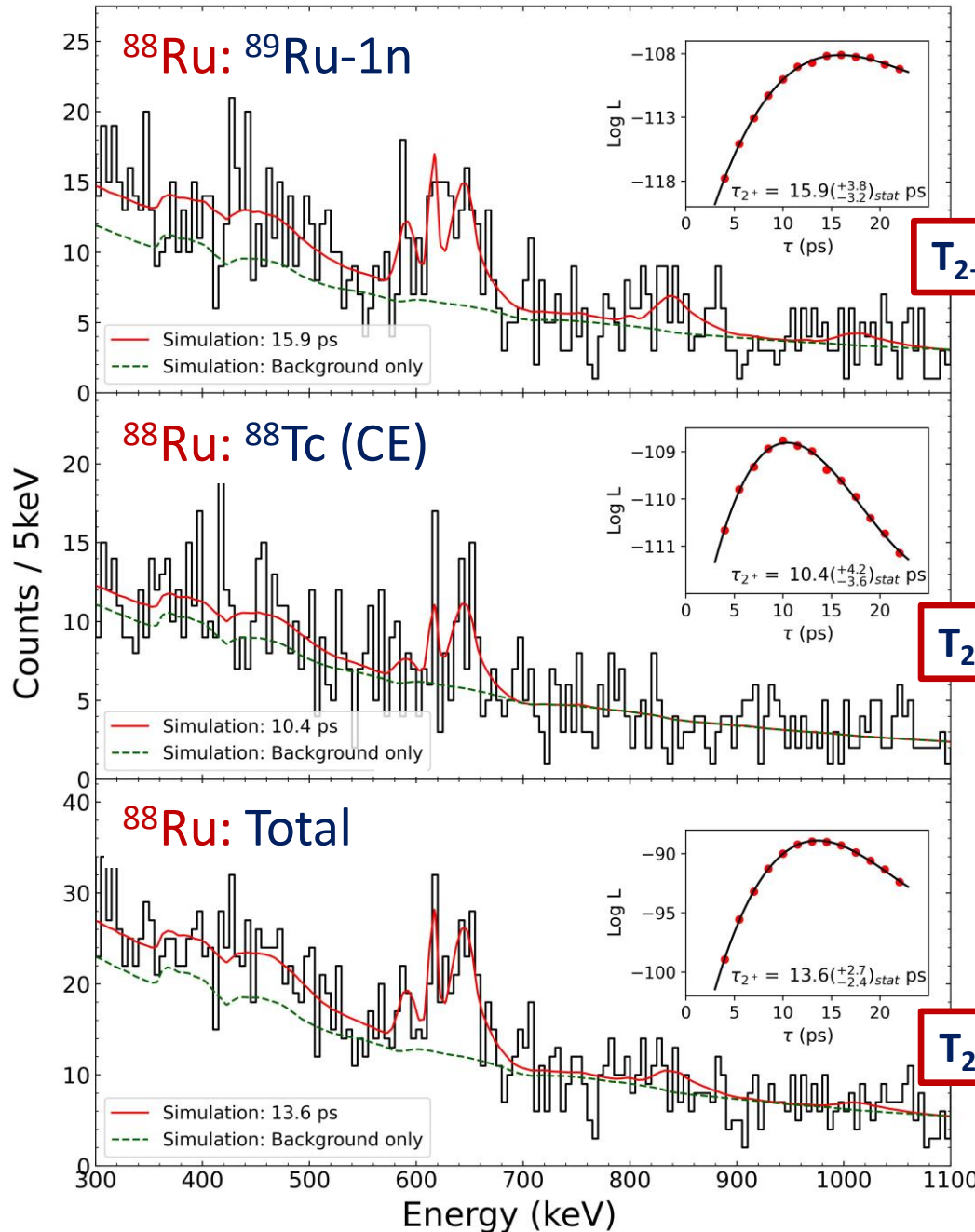

$T_{2+} = 15.9(35_{\text{stat}}) \text{ ps}$

Weighted Average:
13.5(26)ps

$T_{2+} = 10.4(39_{\text{stat}}) \text{ ps}$

$T_{2+} = 13.6(26_{\text{stat}}) \text{ ps}$

14.3(22_{stat}) ps from χ^2

Development of collectivity along N=Z

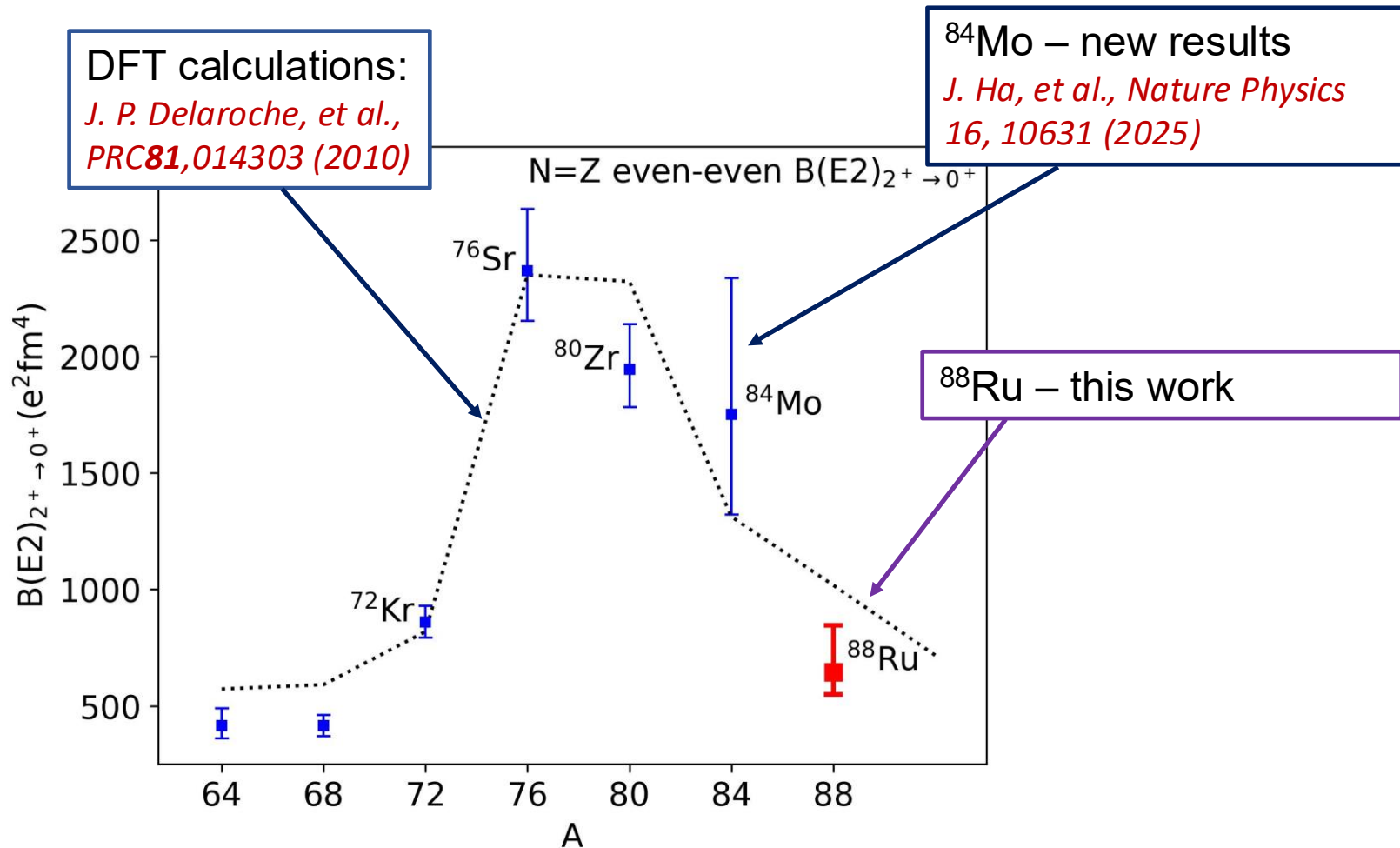

Shell-model: new approach and results

F. Nowacki, D. Dao, A. Poves

J. Ha et al., Nature Physics 16, 10631 (2025)

A.P. Zuker et al, Phys Rev C 92, 024320 (2015)

Large-scale SM: New interaction **ZBM3**, spans the space: $p_{3/2}f_{5/2}p_{1/2} - g_{9/2}d_{5/2}s_{1/2}$

B(E2) results:

LSSM-ZBM3 ($\epsilon_p=1.5, \epsilon_n=0.5$): $558 \text{ e}^2\text{fm}^4$

Experiment: $640_{-100}^{+200} \text{ e}^2\text{fm}^4$

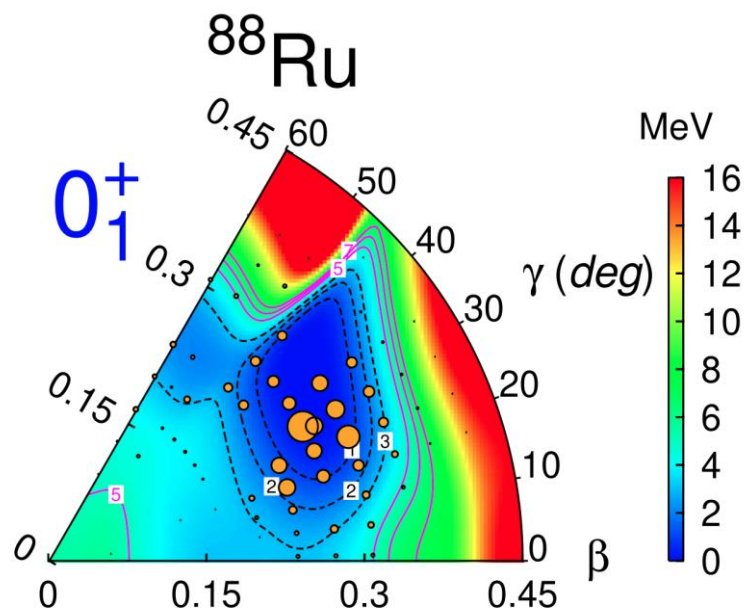

New Discrete Non-Orthogonal (DNO) shell-model approach:

D.D.Dao and F.Nowacki, PRC105, 054314 (2022)

DNO-SM (ZBM3): $616 \text{ e}^2\text{fm}^4$

M. A. Bentley et al. Phys. Rev. Lett. (2026) – in press

Shell-model: new approach and results

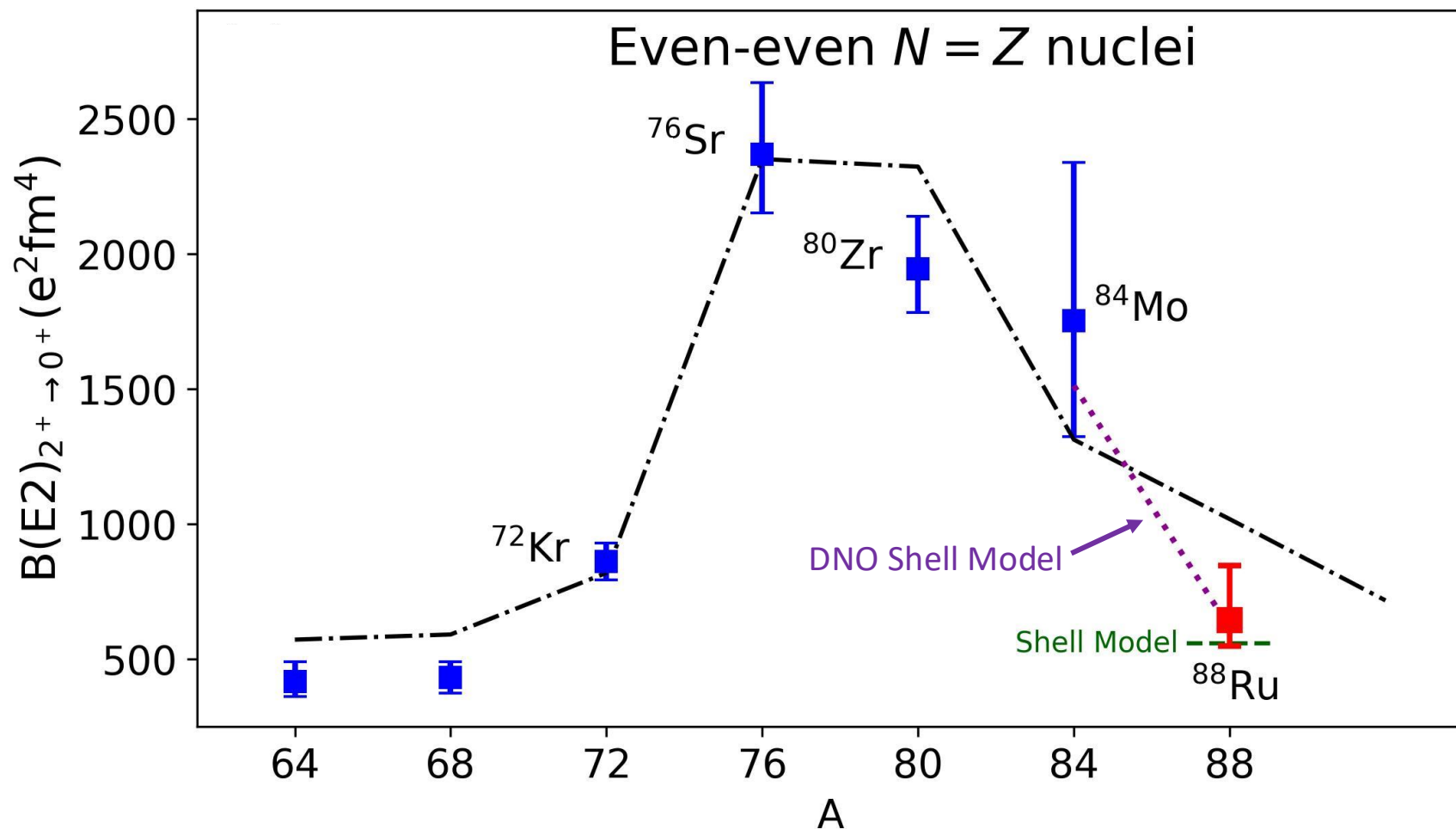

Conclusions

- Successful FRIB experiment – overcoming many challenges
- New data for $B(E2)$ for the heaviest $N=Z$ even-even nucleus ^{88}Ru
- New shell-model approaches for these deformed $N=Z$ systems
ZBM3 interaction, DNO-SM approach...
- Shell-model now can handle the full range of $N=Z$ data

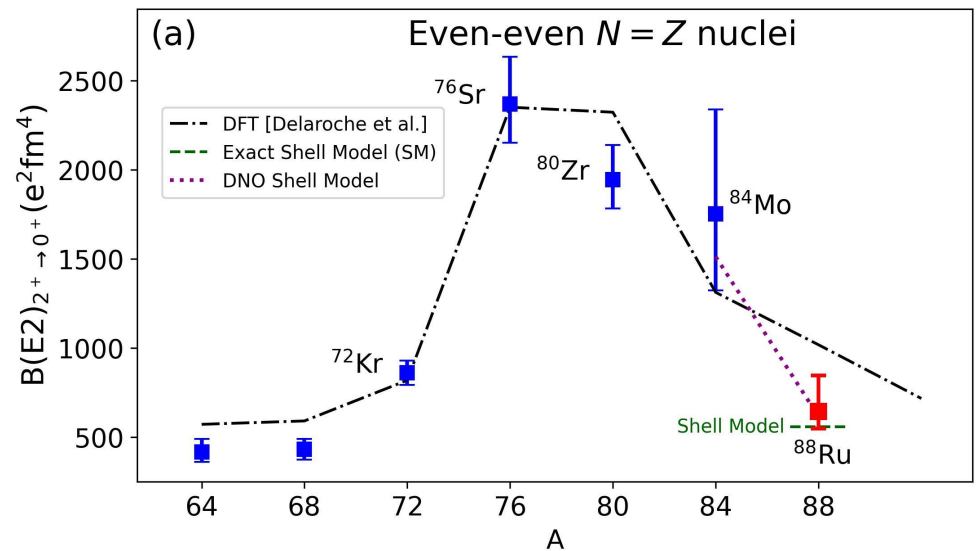



Thanks:

M.A.Bentley, **R.Taniuchi**, **R.Wadsworth**, J.Dobaczewski, D.G.Jenkins, W.Marshall, S.Paschalis, M.Petri. *University of York, U.K.*

A.Gade, M.Basson, T.Beck, J.Chen, A.Douglas, P.Farris, S.Gillespie, A.Hill, H.Iwasaki, , J.Jung, J.Pereira, R.Salinas, A. Sanchez, J.Swartz, C.Tinson, D.Weisshaar. *FRIB/MSU, USA*

X.Pereira-Lopez, *IBS Daejeon, Korea*

K.Wimmer, *GSI/FAIR, Germany*

B.Cederwall, *KTH Stockholm, Sweden*

M.Doncel, *University of Stockholm, Sweden*

D.Dao, F.Nowacki *CNRS, Strasbourg, France*

S.M.Lenzi, *Padova, Italy*

Thanks to FRIB team – especially Marc Hausmann and
Brad Sherill (ARIS)