

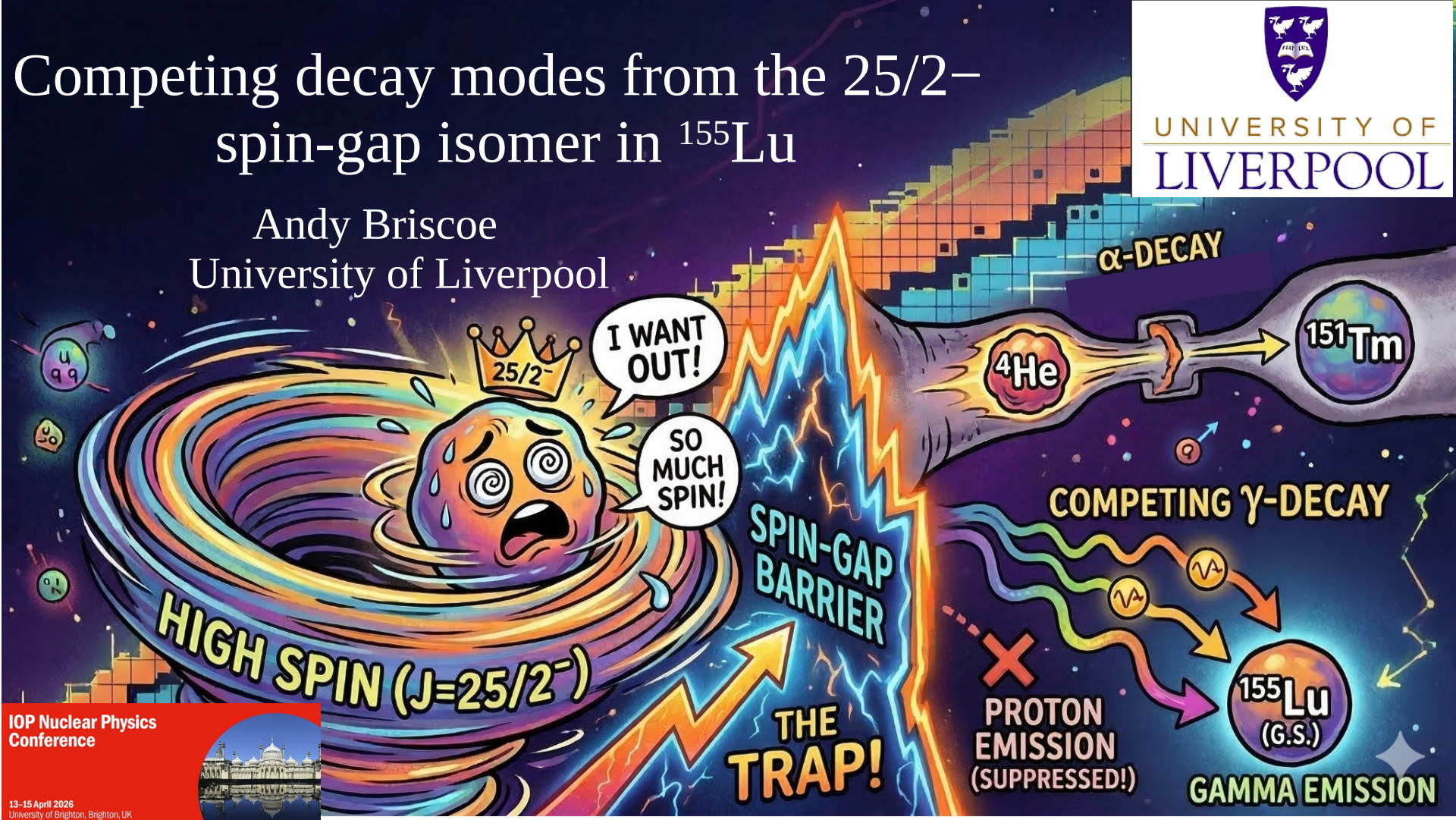

# Competing decay modes from the 25/2- spin-gap isomer in $^{155}\text{Lu}$

Andy Briscoe  
University of Liverpool



# Isomers at N=84 and $^{155}\text{Lu}$ motivation

Alpha Decay Studies of Very Neutron Deficient Isotopes of Hf, Ta, W, and Re

S. Hofmann, W. Faust, G. Münzenberg, W. Reisdorf and P. Armbruster  
Gesellschaft für Schwerionenforschung, Darmstadt, Germany

K. Güttner and H. Ewald  
II. Physikalisches Institut, Universität Gießen, Gießen, Germany

Received November 27, 1978; Revised Version January 31, 1979

$\alpha$ -decaying high-spin isomeric states were first observed in the N=84 isotones by Sigurd Hoffman in 1979 at SHIP

High energy alpha decay lines were observed from a range of beam and targets.

$E_\alpha = 7.4$  MeV,  $t_{1/2} = 2.7$  ms and  $E_\alpha = 7.8$  MeV,  $t_{1/2} = 0.5$  ms was reported for these alpha decays, but could not be identified.

Subsequently assigned to high-spin decays of  $^{155}\text{Lu}$  and  $^{156}\text{Hf}$

Since these initial experiments, several several alpha decaying spin-gap isomers in this region

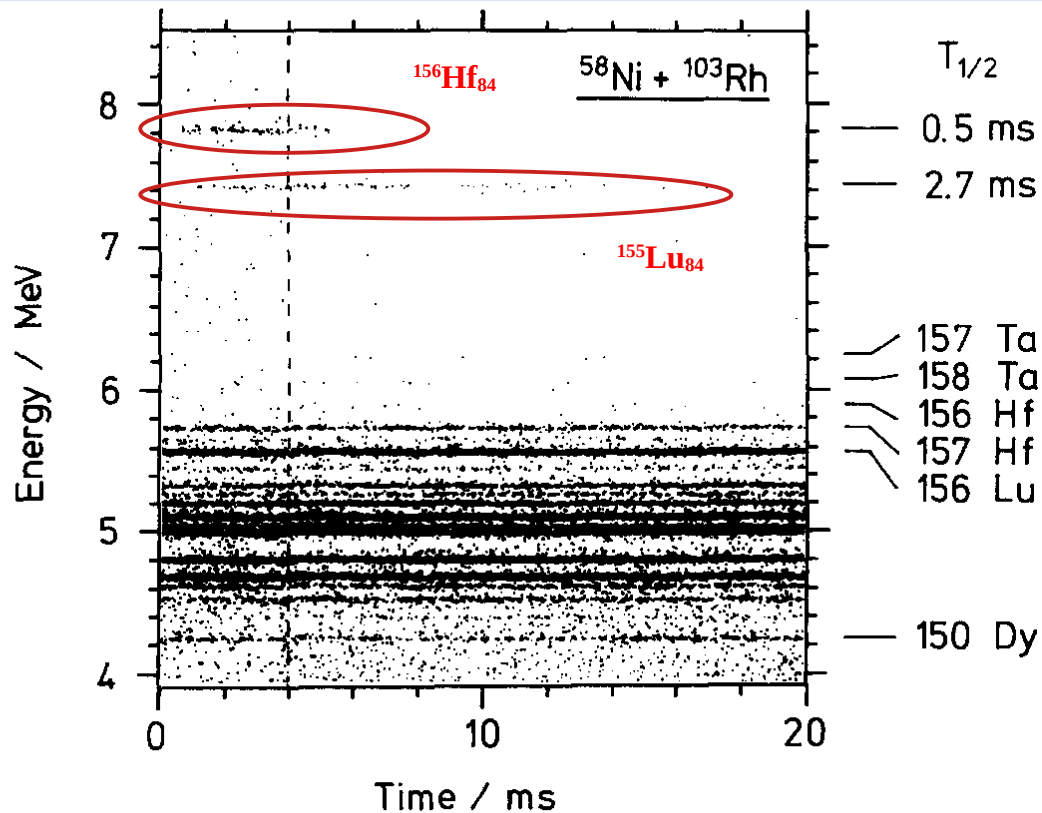



# Isomers at N=84 and $^{155}\text{Lu}$ motivation

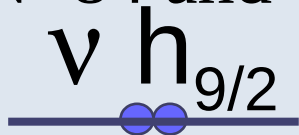

$\pi h_{11/2}$

Valence orbitals above doubly magic  $^{146}\text{Gd}$

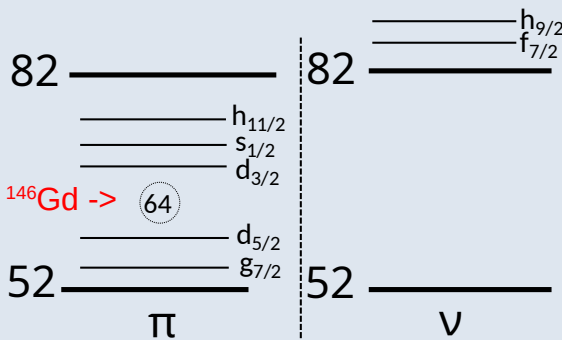

$\pi\nu$  attractive  
monopole interactive  
increases as  $\pi h_{11/2}$   
orbital occupancy  
decreases above  $Z = 64$  (Gd)

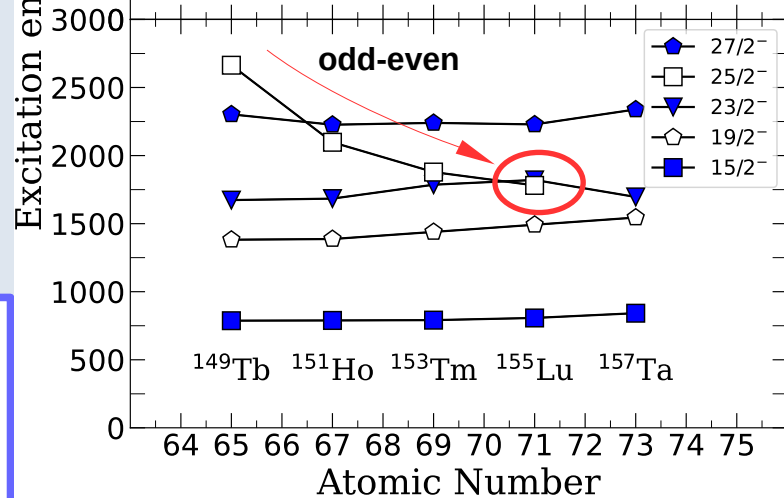
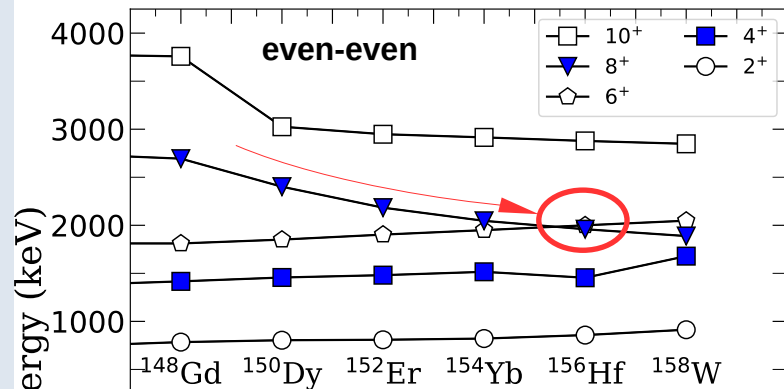

# Isomers at N=84 and $^{155}\text{Lu}$ motivation

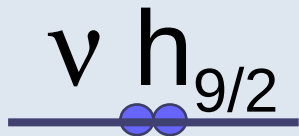

$\pi h_{11/2}$

Valence orbitals  
above doubly  
magic  $^{146}\text{Gd}$

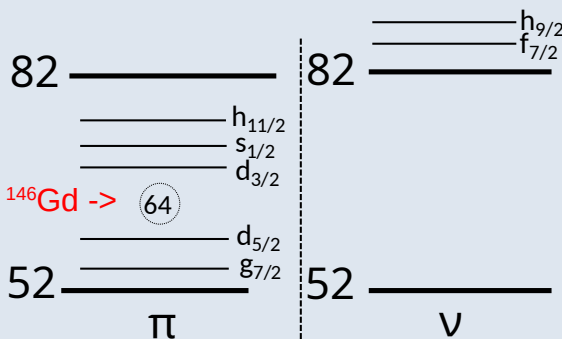

$\pi\nu$  attractive  
monopole interactive  
increases as  $\pi h_{11/2}$   
orbital occupancy  
decreases above  $Z = 64$  (Gd)

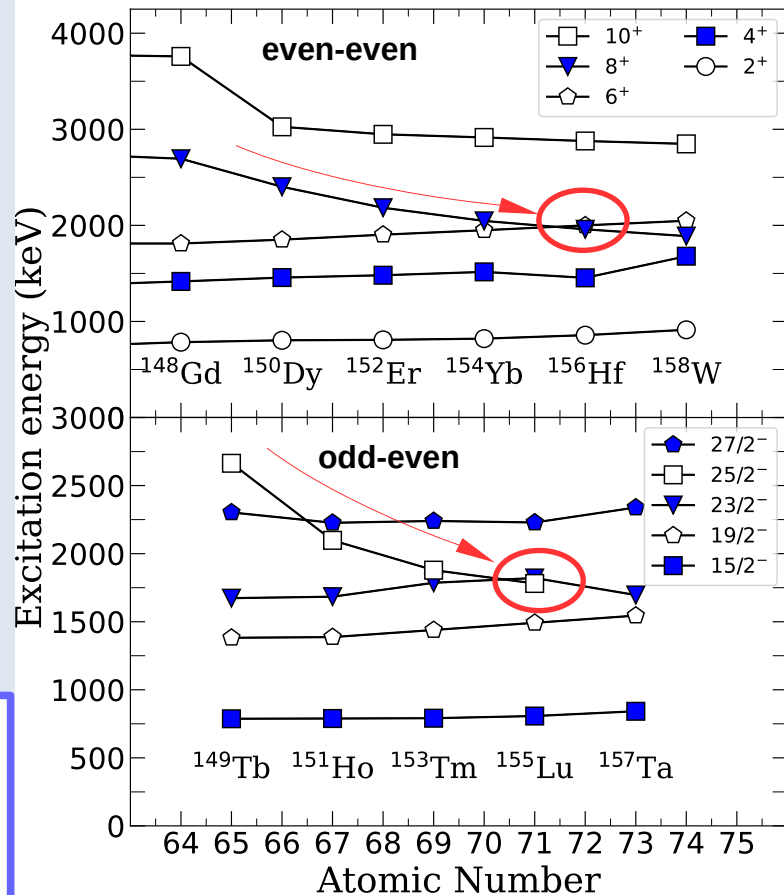

# Isomers at N=84 and $^{155}\text{Lu}$ motivation

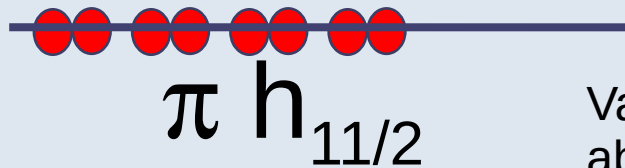
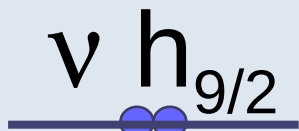

Valence orbitals  
above doubly  
magic  $^{146}\text{Gd}$

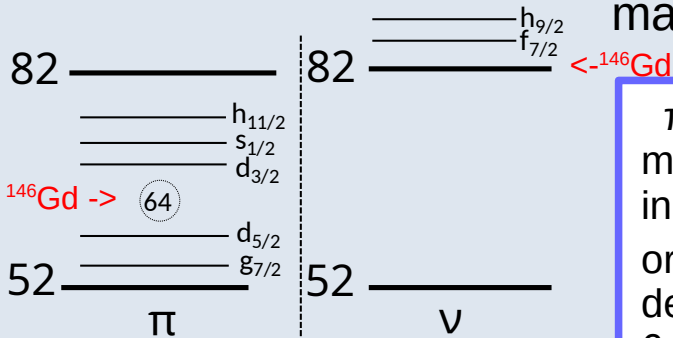

$\pi\nu$  attractive  
monopole interactive  
increases as  $\pi h_{11/2}$   
orbital occupancy  
decreases above  $Z =$   
64 (Gd)

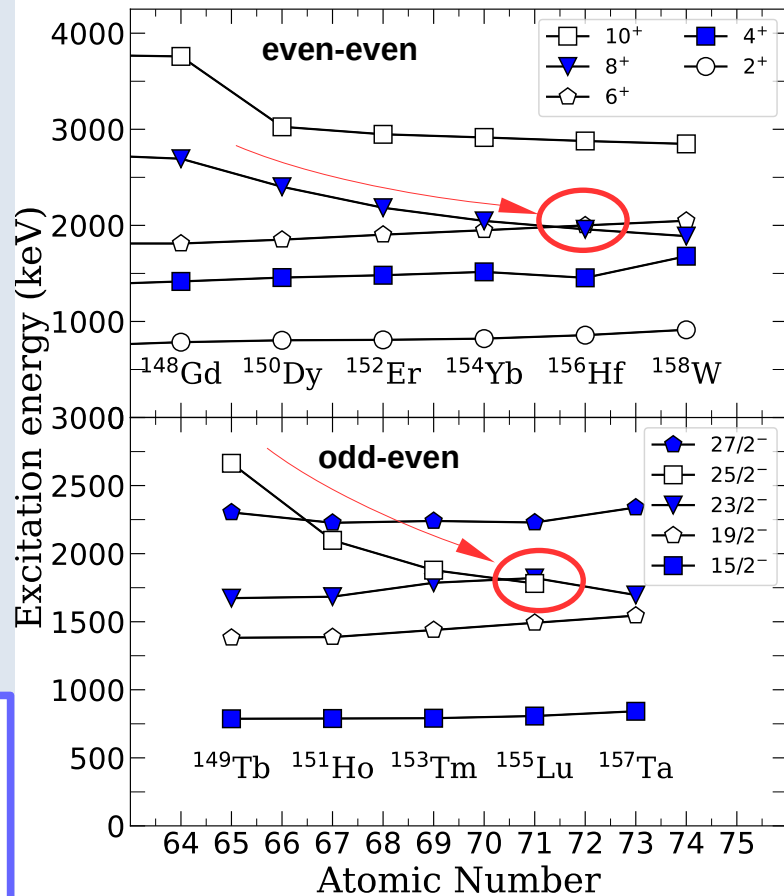

# Isomers at N=84 and $^{155}\text{Lu}$ motivation

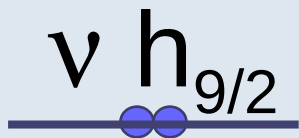

Valence orbitals  
above doubly  
magic  $^{146}\text{Gd}$

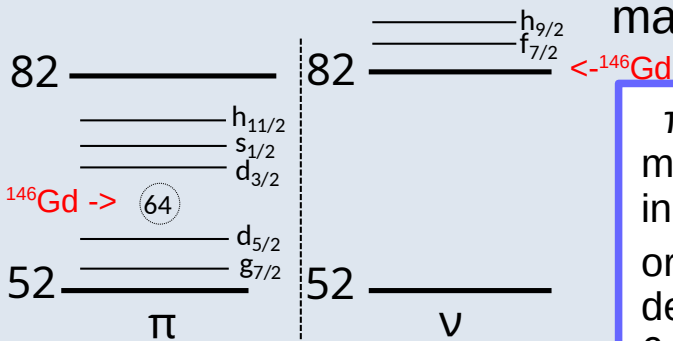

$\pi\nu$  attractive  
monopole interactive  
increases as  $\pi h_{11/2}$   
orbital occupancy  
decreases above  $Z =$   
64 (Gd)

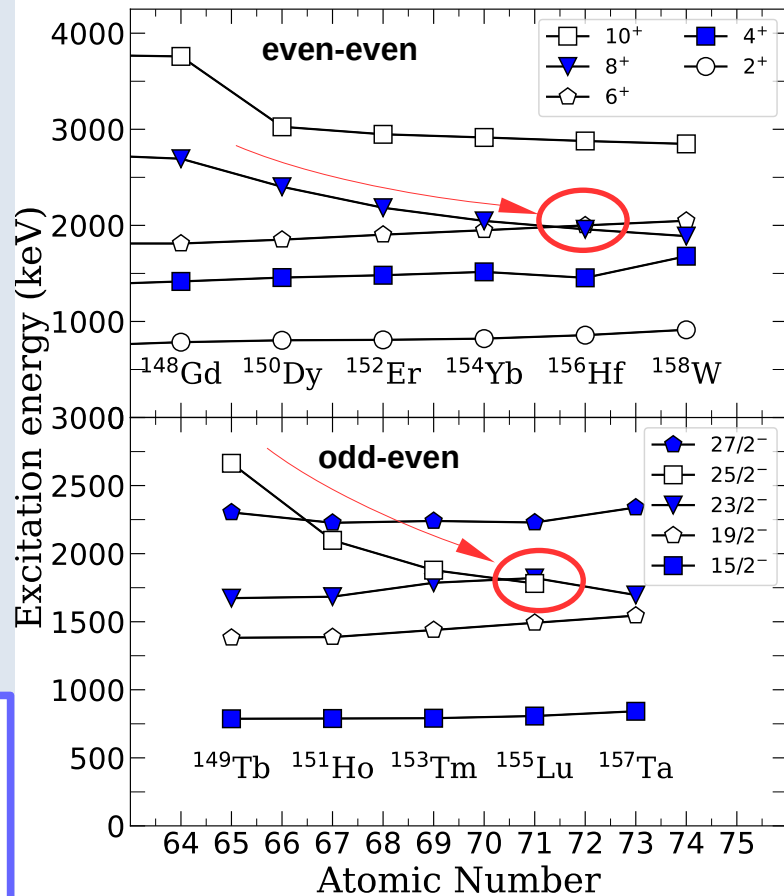

# Isomers at N=84 and $^{155}\text{Lu}$ motivation

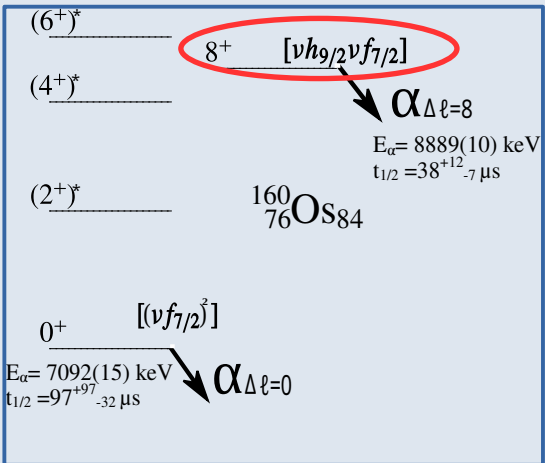
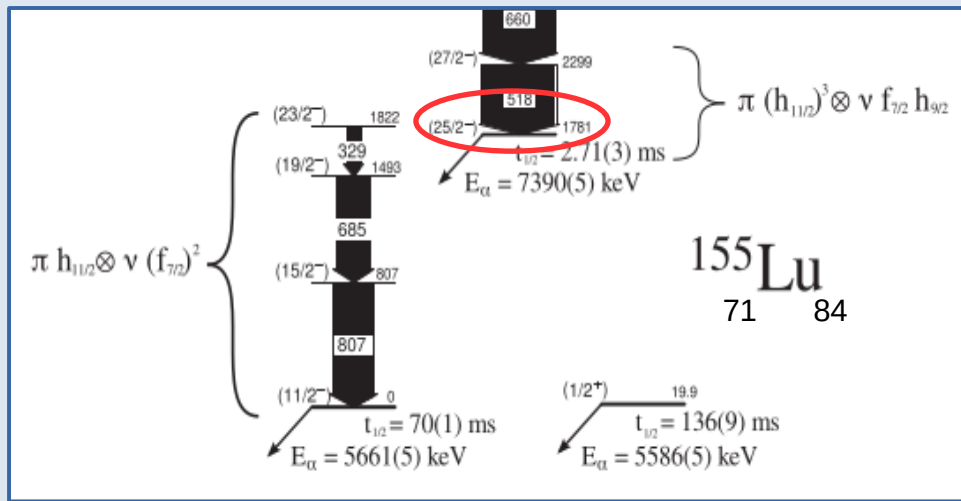
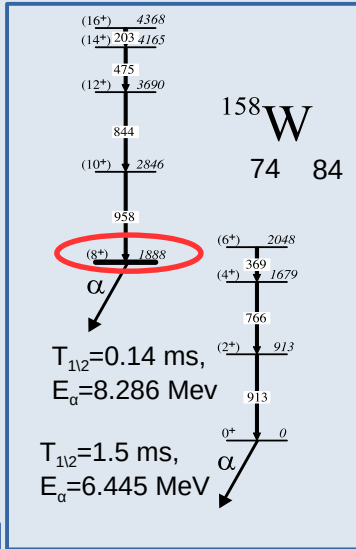
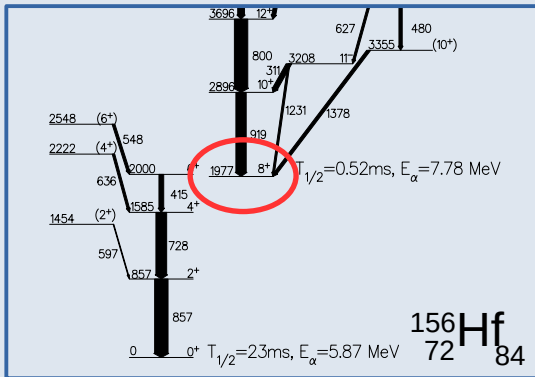

Several high-spin ( $\Delta\ell = 8$ ) alpha-decaying isomers observed in N=84 isotones arising from  $\pi h_{11/2} \nu h_{9/2}$  interaction.

So far only observed only alpha emission observed from these states.

# Isomers at N=84 and $^{155}\text{Lu}$ motivation

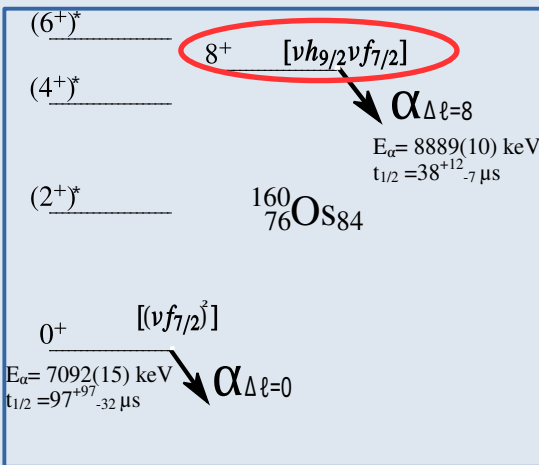
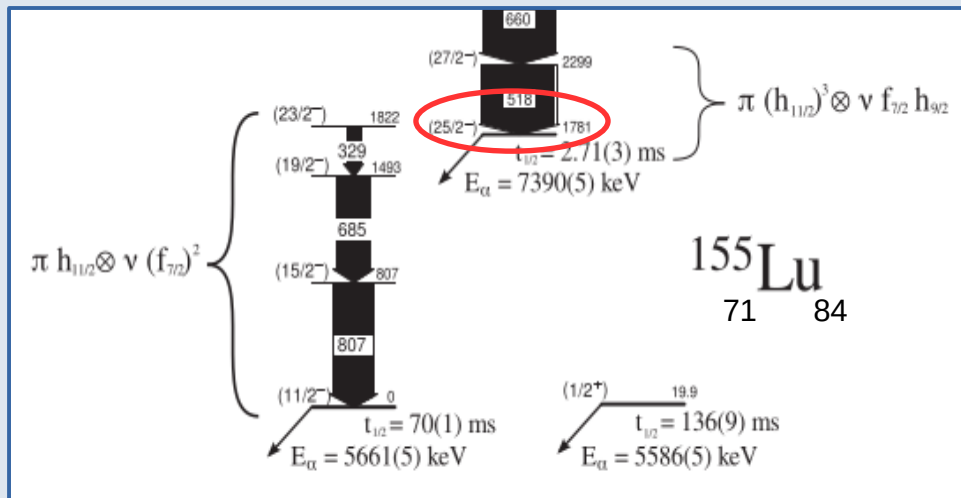
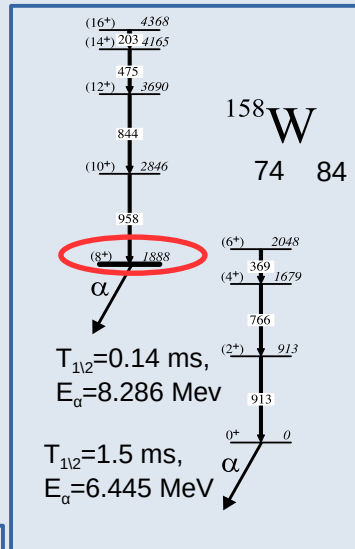
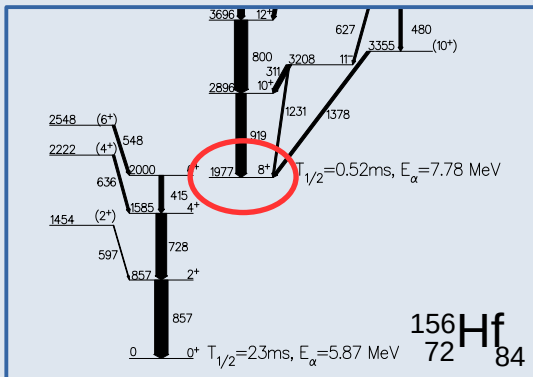

Several high-spin ( $\Delta\ell = 8$ ) alpha-decaying isomers observed in N=84 isotones arising from  $\pi h_{11/2} \nu h_{9/2}$  interaction.

So far only observed only alpha emission observed from these states.

We wanted to study the possibility of competing EM modes, today will show results on on the 2.71 ms 25/2- state in  $^{155}\text{Lu}$ .

Lowest possible competing multipolarity between 25/2- and 19/2- would be an M3 transition.

Will decay with the state half-life of 2.71 ms, eventually feeding 11/2- alpha-decaying ground state.

# Correlation of fusion products

(300 um- thick Micron BB20)  
Optimal for  $\alpha$  and protons while  
reducing  $\beta$  background. Sensitive  
to low energy conversion electrons.  
72x192=13824 pixels

Target  
( $^{102}\text{Pd}$ )

$^{160}\text{W}$  Compound  
Nucleus,  $^{155}\text{Lu}$  via  
3p2n channel

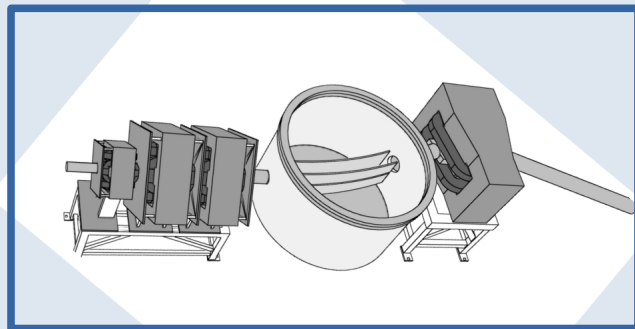

Recoil Separator  
(MARA)

$\approx 7\text{ m}$   $\rightarrow$  Flight time  $\approx 500\text{ ns}$

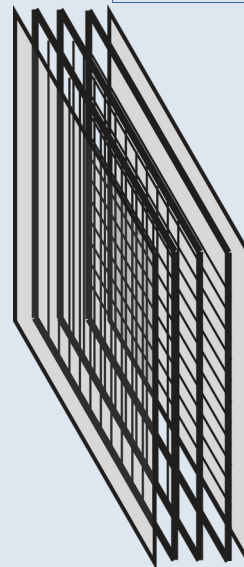

MWPC  
(transmission  
detection)

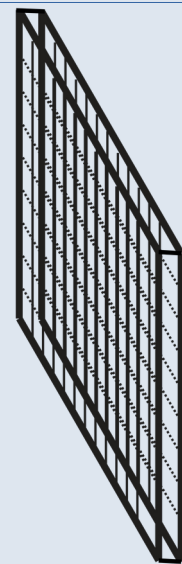

DSSD  
(implantation  
detector)

TOF

40 cm

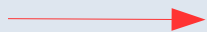

Beam  
(from  
Cyclotron,  
 $^{58}\text{Ni}$ )

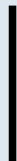

# Ancillary detectors

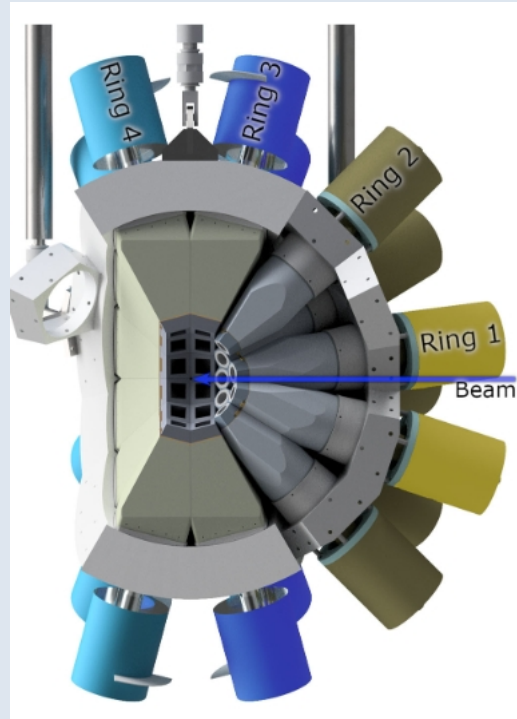

**JUROGAM3 Array:** 24 Clover and 15 Phase 1 Ge detectors

The JUROGAM 3 spectrometer

J. Pakarinen<sup>1,2</sup>, J. Ojala<sup>1</sup>, P. Ruotsalainen<sup>1</sup>, H. Tani<sup>1,2</sup>, H. Badran<sup>1,4</sup>, T. Calverley<sup>1,2</sup>, J. Hilton<sup>1,2</sup>, T. Grahn<sup>1</sup>, P. T. Greenlees<sup>1</sup>, M. Hytönen<sup>1</sup>, A. Illana<sup>1</sup>, A. Kauppinen<sup>1</sup>, M. Luoma<sup>1,3</sup>, P. Papadakis<sup>1,5</sup>, J. Partanen<sup>1</sup>, K. Porras<sup>1</sup>, M. Puskala<sup>1</sup>, P. Rakkila<sup>1</sup>, K. Ranttila<sup>1</sup>, J. Sarén<sup>1</sup>, M. Sandzelius<sup>1</sup>, S. Szwecl<sup>1</sup>, J. Tuunanen<sup>1</sup>, J. Uusitalo<sup>1</sup>, G. Zimba<sup>1</sup>

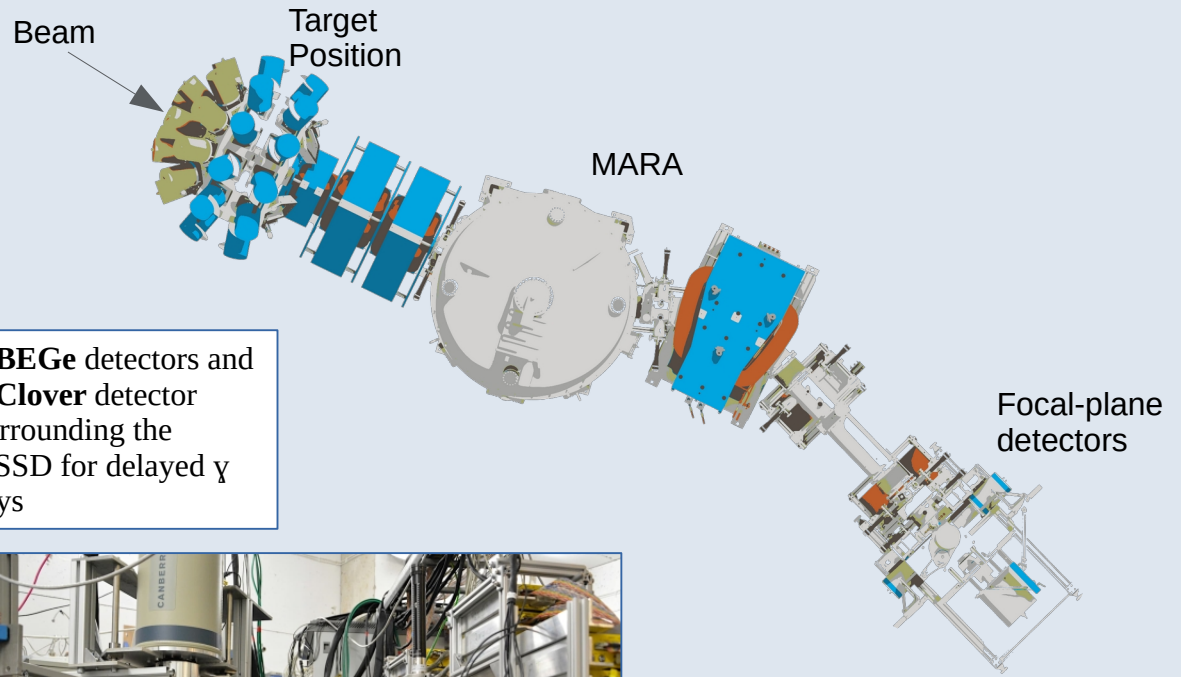

**3 BEGe detectors and 1 Clover detector** surrounding the DSSD for delayed  $\gamma$  rays

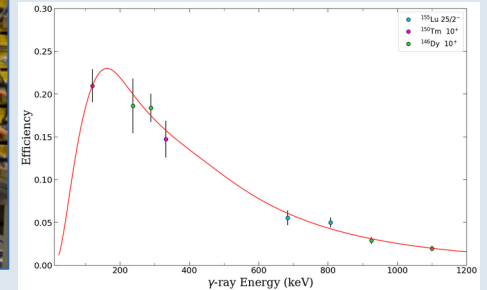
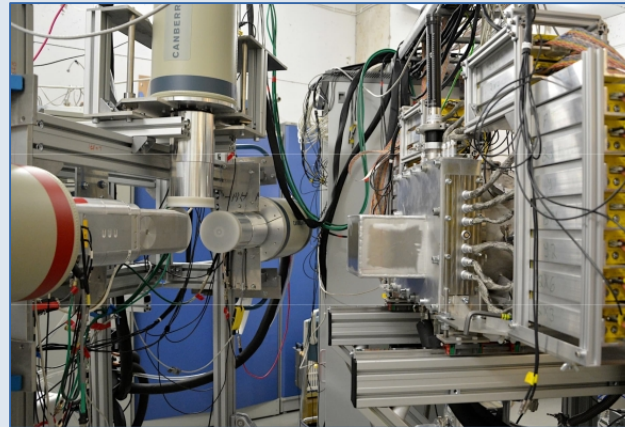

# Isomer search: $\gamma$ rays

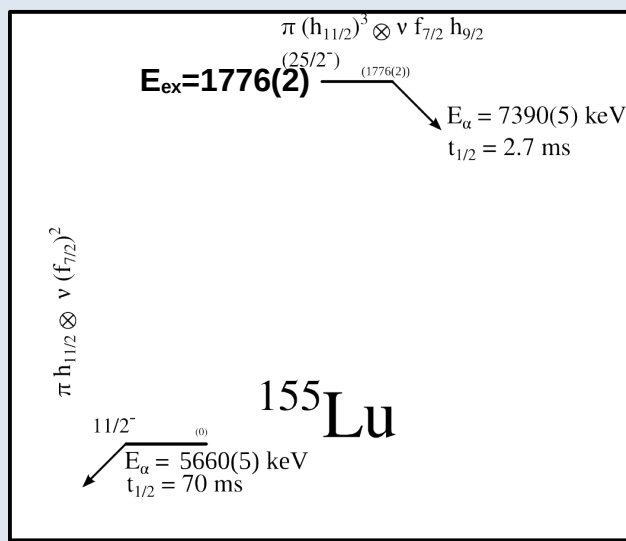
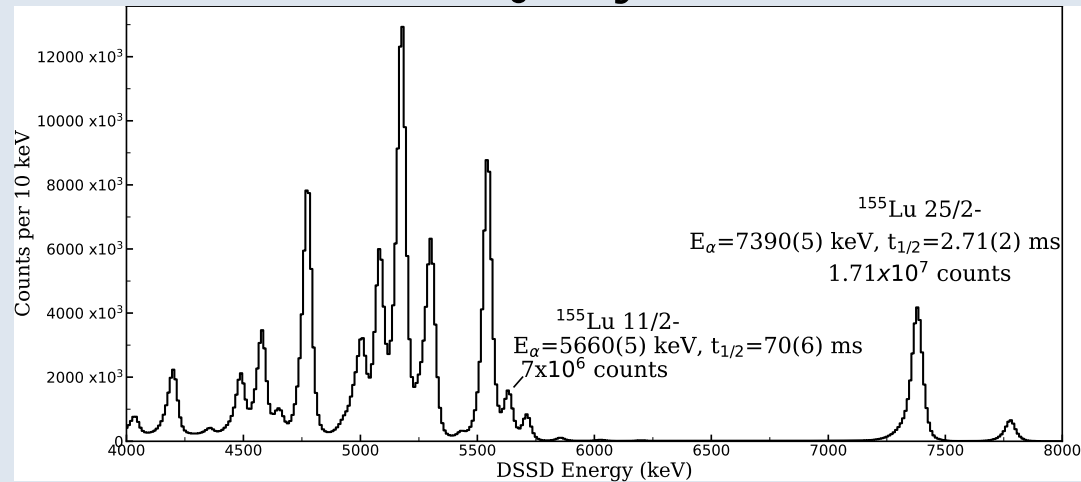

# Isomer search: $\gamma$ rays

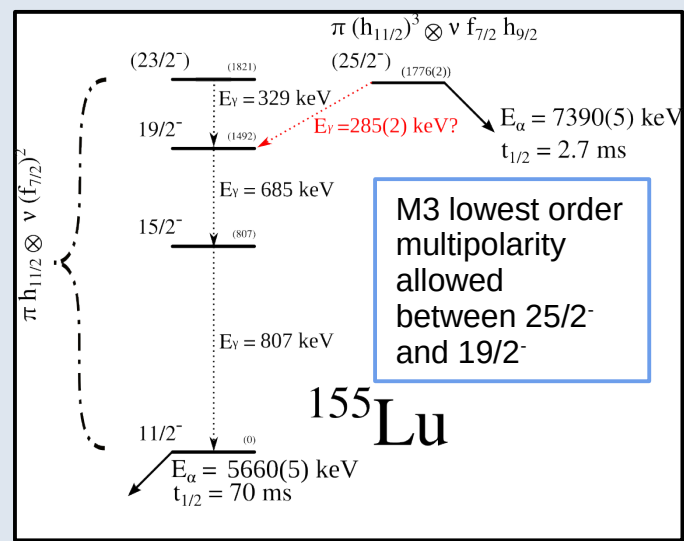
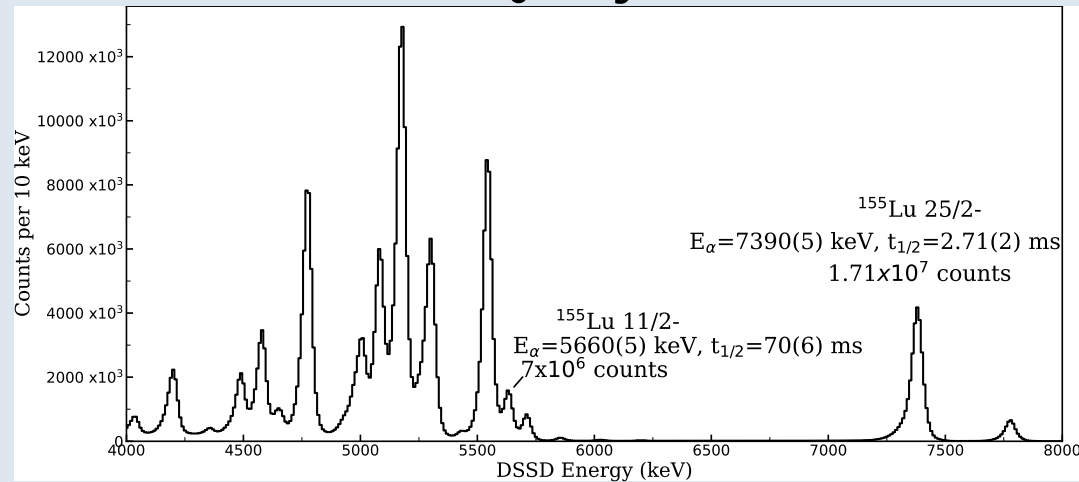

In-beam  $\gamma$  rays above 11/2<sup>-</sup>  $\alpha$  decay, confirms that M3 isomeric  $\gamma$  ray should be followed by 685 and 807, not 329

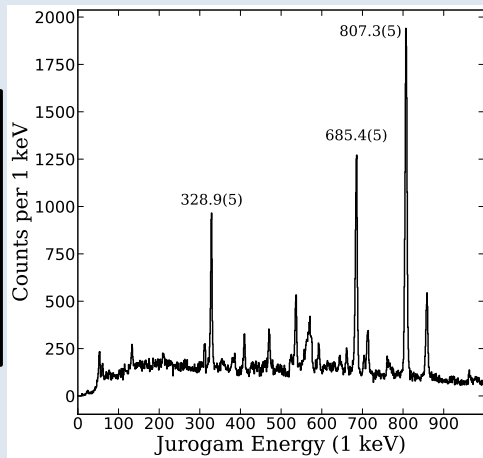

# Isomer search: $\gamma$ rays

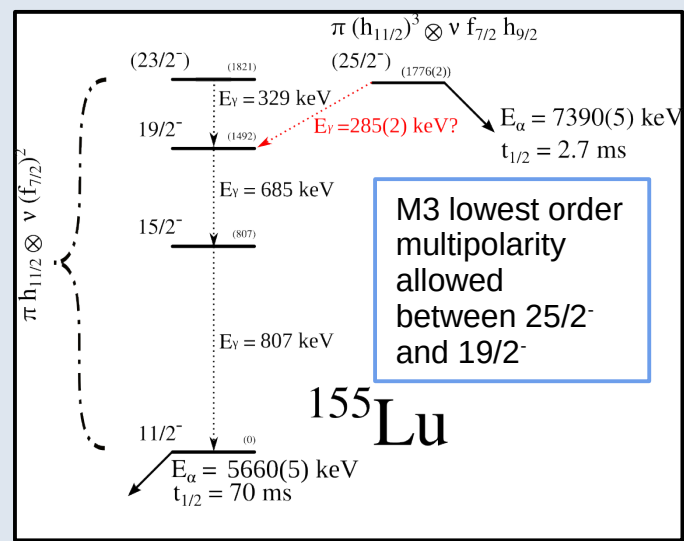
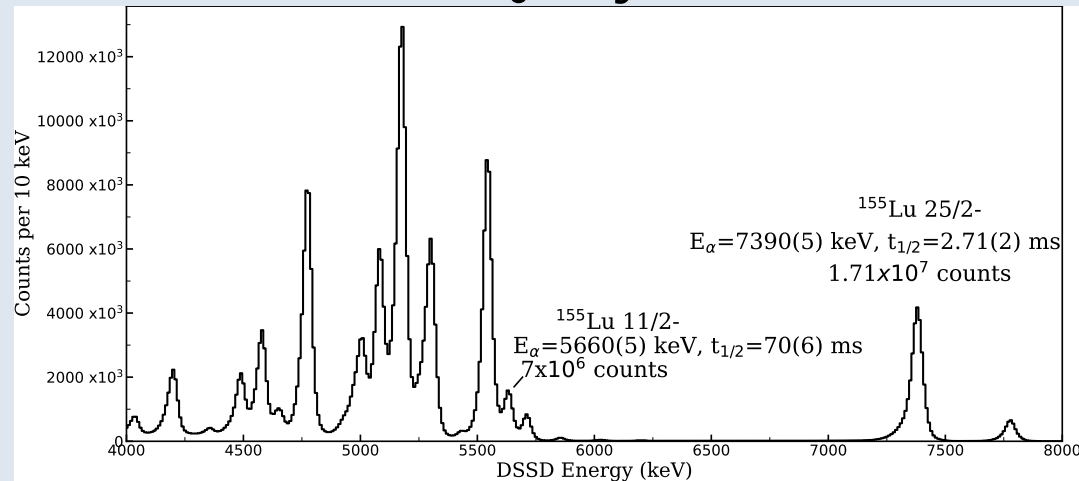

In-beam  $\gamma$  rays above 11/2-  $\alpha$  decay, confirms that M3 isomeric  $\gamma$  ray should be followed by 685 and 807, not 329

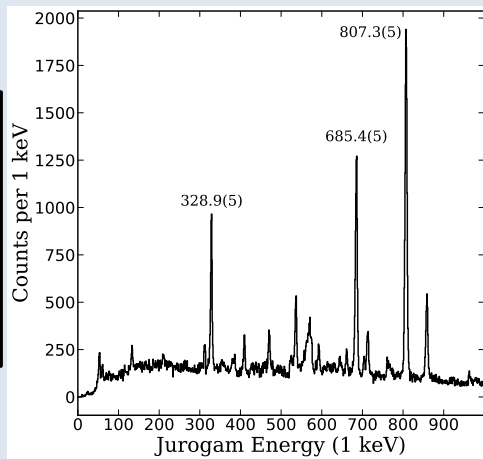

Impossible to correlated 2.71 ms gamma-rays. Too much background. A different approach is needed..

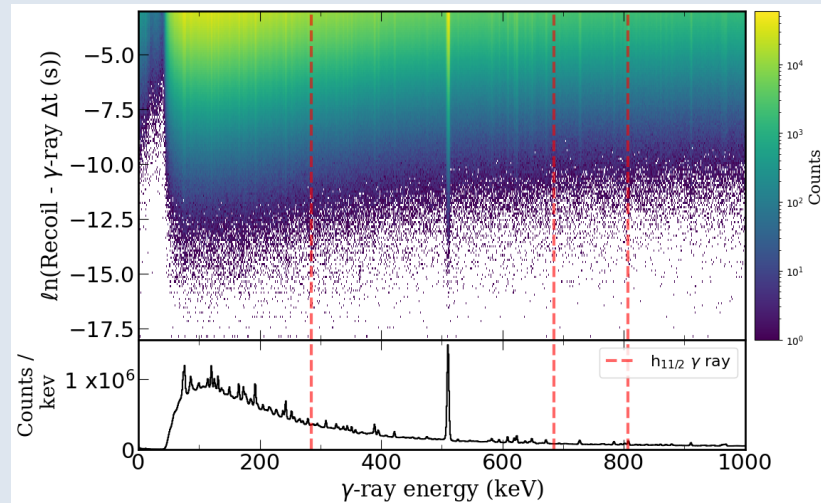

# Competing EM Branch: DSSD internal conversion

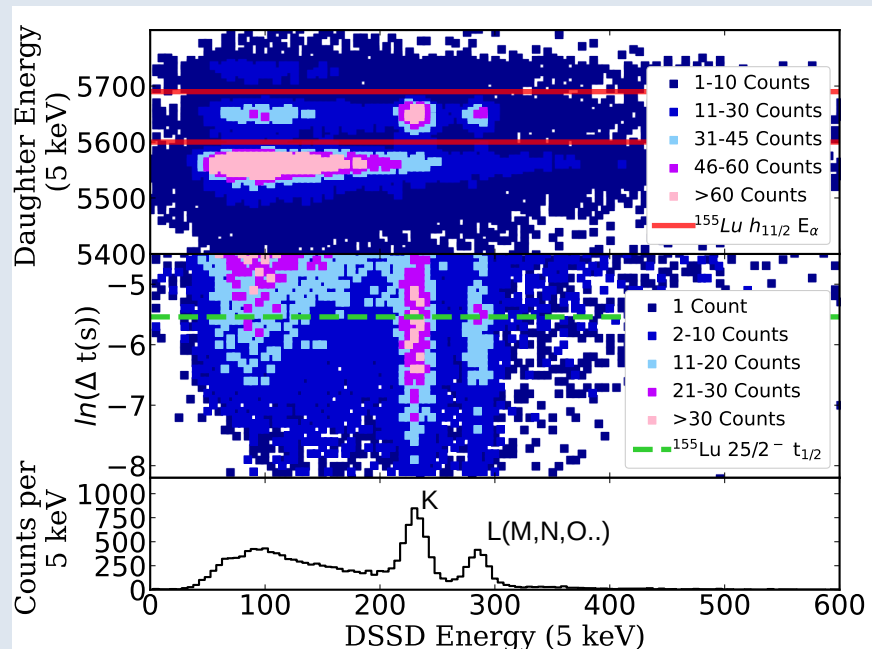

Single pixel correlations

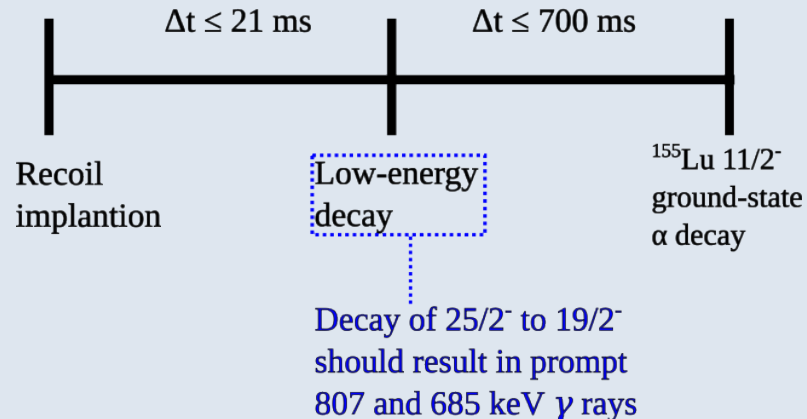

Can take advantage of the segmentation of the DSSD when looking for longer lived internally converted transitions.

Decays correlated **before** the 5660 keV  $11/2^-$   $\alpha$  decay reveals the conversion electron spectrum from a single delayed transition.

# Competing EM Branch: DSSD internal conversion

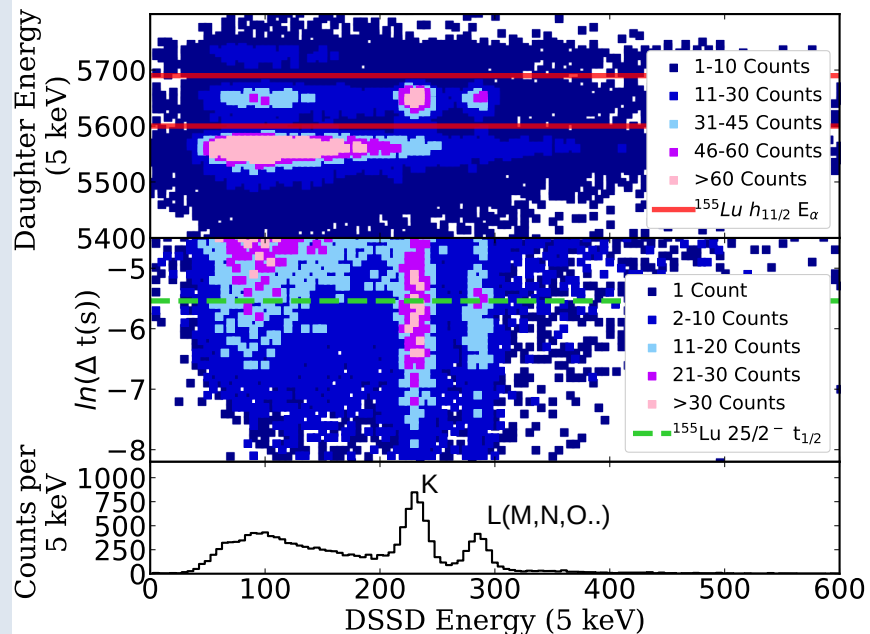

Prompt  $\gamma$ -ray coincidences with the delayed electrons show that it is followed by 685 and 807 keV  $\gamma$  rays

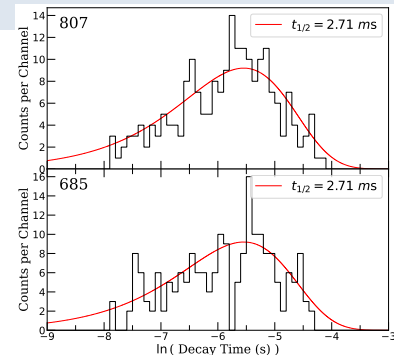
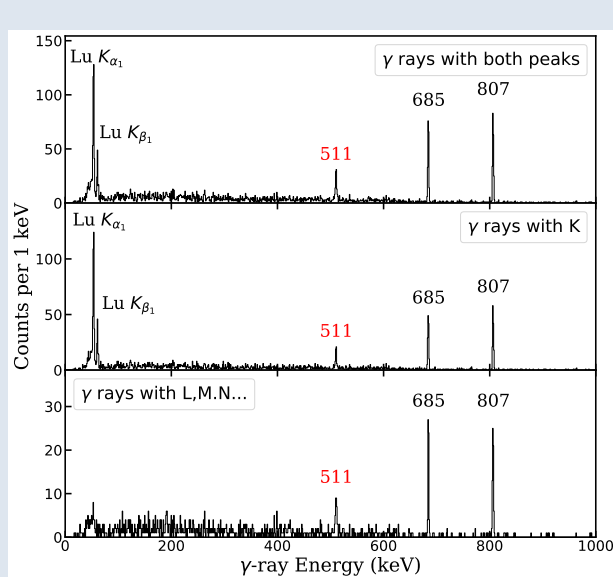
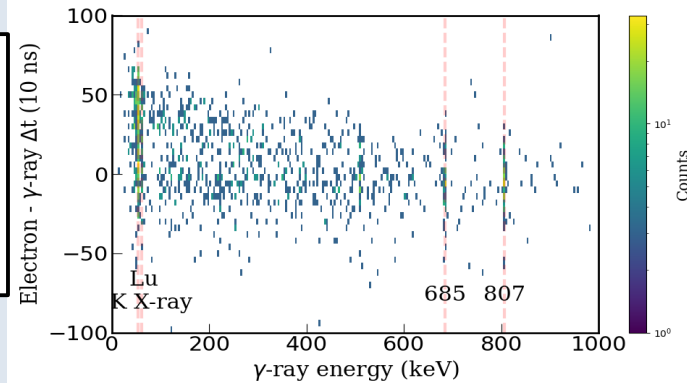

Can take advantage of the segmentation of the DSSD when looking for longer lived internally converted transitions.

Decays correlated **before** the 5660 keV  $11/2^- \alpha$  decay reveals the conversion electron spectrum from a single delayed transition.

Time distribution of electrons &  $\gamma$  rays consistent with 2.71 ms of  $25/2^-$  decay. Competing branch from this state!

# Competing EM Branch: transition energy & branch

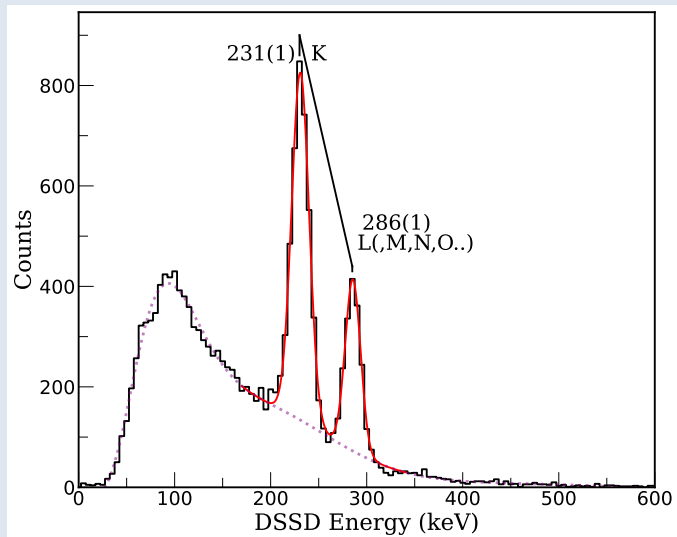

Need to take care when measuring energy of conversion electrons from implanted nuclei. Dedication electron calibration (source + implanted nuclei).

Following conversion, atomic relaxation effects (X-rays & Auger electrons) sum with conversion electrons (**diagram**).

For 300  $\mu\text{m}$  DSSD:

K X-ray ( $\sim 55$  keV) not stopped (HVL 8000  $\mu\text{m}$ )

L X-ray ( $\sim 8$  keV) fully stopped (HVL 40  $\mu\text{m}$ )

Need to sum K line with average K X-ray from TOI : 55.3 keV

Atomic relaxation energies  $<$  K sum.

## Measured transition energy

using K:  $231(1)$  keV + 55.3 keV = **286.3(1) keV**, using L(M,NO): **286(1) keV**

Isomer excitation energy ( 806.7(3) + 684.8(3) + 286(1) ) = **1778(1) keV**

Consistent with **1776(2) keV** from  $\alpha$  decays.

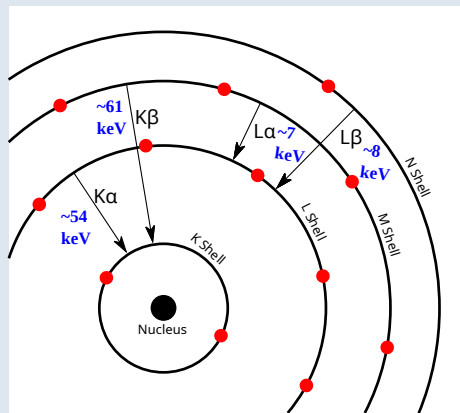

# Competing EM Branch: transition energy & branch

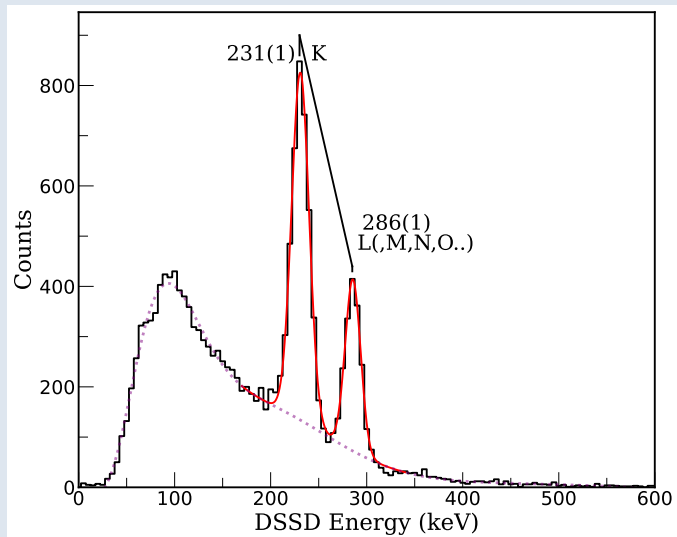

Need to take care when measuring energy of conversion electrons from implanted nuclei. Dedication electron calibration (source + implanted nuclei).

Following conversion, atomic relaxation effects (X-rays & Auger electrons) sum with conversion electrons (**diagram**).

Need to sum K line with average K X-ray from TOI : 55.3 keV

Atomic relaxation energies < K sum.

For 300 um DSSD:

K X-ray (~55 keV) not stopped (HVL 8000 um)

L X-ray (~8 keV) fully stopped (HVL 40 um)

## Measured transition energy

using K:  $231(1) \text{ keV} + 55.3 \text{ keV} = 286.3(1) \text{ keV}$ , using L(M,NO): **286(1) keV**

Isomer excitation energy (  $806.7(3) + 684.8(3) + 286(1) ) = 1778(1) \text{ keV}$

Consistent with **1776(2) keV** from  $\alpha$  decays.

## EM branching ratio:

Ratio of total number of  $25/2^- \alpha$  decays ( $17.053(4) \times 10^6$ ) to number of electrons in both peaks (**4550(140)**) after correcting for efficiencies.

**Conversion electron: 0.118(6)%**

Total ICC (M3) = 2.92 ,  **$\gamma$ -ray branch: 0.041(2)%**

**Total EM branch: 0.159(6)%**

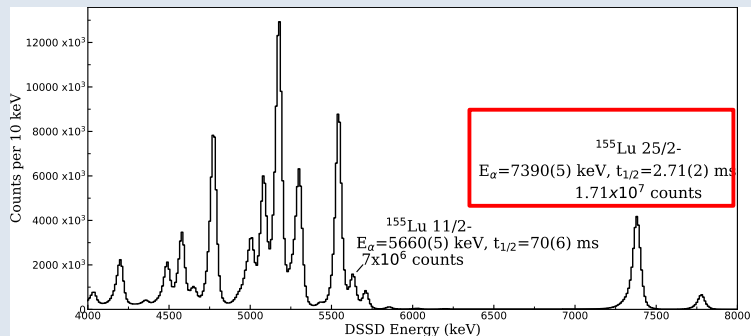

# Competing EM Branch: Strength and systematics

Coincidence with 807 keV ( $15/2^- \rightarrow 11/2^-$ ) and 685 keV ( $19/2^- \rightarrow 15/2^-$ ) can clean up the spectrum for measuring multipolarity and transition strengths through deconvolution.

Fitting intensities of the K conversion line and comparing the calculated area with that expected for an M3 and E4 transition show that **M3/E4 mixing of 5(2)%** is required.

**Weisskopf single particle estimates** for 286 keV transition

M3: 0.519 s      E4: 6880 s

The 0.041(2)%  $\gamma$ -ray branch results in

**B(M3) = 0.073(4) W.u**    and    **B(E4) = 50(20) W.u**

**Shell model calculations** (inert  $^{146}\text{Gd}$  core,  $\pi$  valence space:  $d_{3/2}$ ,  $s_{1/2}$ , and  $h_{11/2}$  orbitals and  $\nu$ :  $h_{9/2}$ ,  $f_{7/2}$ ,  $f_{5/2}$ ,  $p_{3/2}$ ,  $p_{1/2}$ , and  $i_{13/2}$  orbitals.)

**B(M3) ( $25/2^- \rightarrow 19/2^-$ ) =  $149 \mu_N^2 \text{fm}^4 = 0.108 \text{ W.u}$**

**B(E4) ( $25/2^- \rightarrow 19/2^-$ ) =  $19322 e^2 \text{fm}^8 = 0.54 \text{ W.u}$**

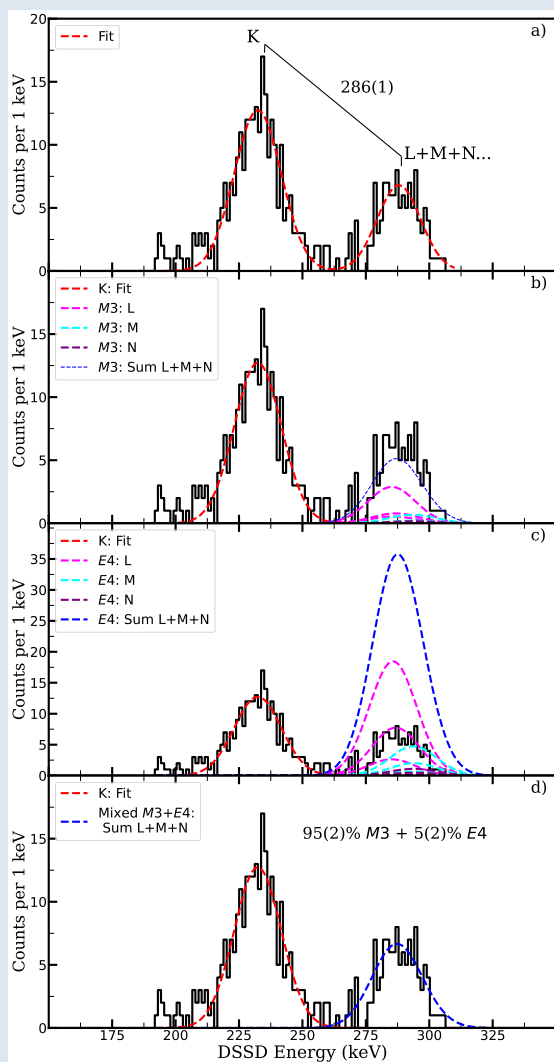

# Competing EM Branch: Strength and systematics

Coincidence with 807 keV ( $15/2^- \rightarrow 11/2^-$ ) and 685 keV ( $19/2^- \rightarrow 15/2^-$ ) can clean up the spectrum for measuring multipolarity and transition strengths through deconvolution.

Fitting intensities of the K conversion line and comparing the calculated area with that expected for an M3 and E4 transition show that **M3/E4 mixing of 5(2)%** is required.

**Weisskopf single particle estimates** for 286 keV transition

M3: 0.519 s      E4: 6880 s

The 0.041(2)%  $\gamma$ -ray branch results in

**$B(M3) = 0.073(4)$  W.u**    and  **$B(E4) = 50(20)$  W.u**

**Shell model calculations** (inert  $^{146}\text{Gd}$  core,  $\pi$  valence space:  $d_{3/2}$ ,  $s_{1/2}$ , and  $h_{11/2}$  orbitals and  $\nu$ :  $h_{9/2}$ ,  $f_{7/2}$ ,  $f_{5/2}$ ,  $p_{3/2}$ ,  $p_{1/2}$ , and  $i_{13/2}$  orbitals.)

**$B(M3)$  ( $25/2^- \rightarrow 19/2^-$ ) =  $149 \mu_N^2 \text{fm}^4 = 0.108$  W.u**

**$B(E4)$  ( $25/2^- \rightarrow 19/2^-$ ) =  $19322 e^2 \text{fm}^8 = 0.54$  W.u**

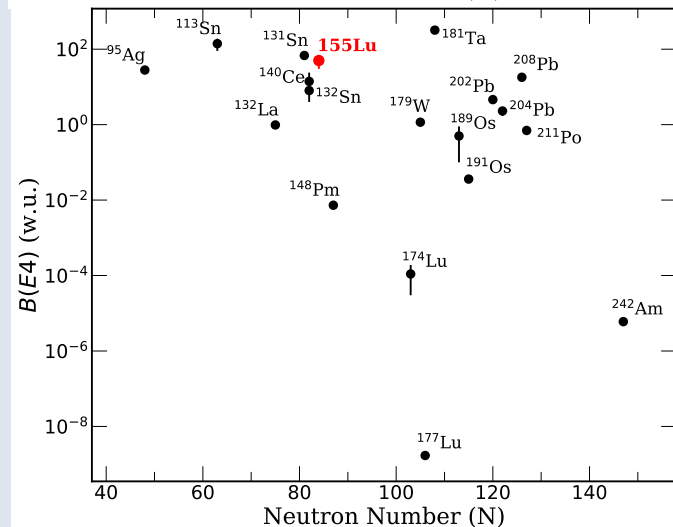
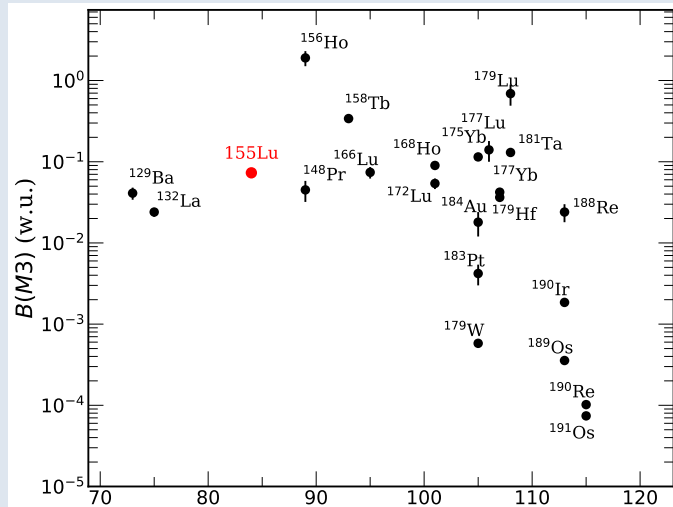

# Outlook, future work and thanks!



UNIVERSITY OF  
LIVERPOOL

A weak competing EM decay observed for the first time from N=84 alpha-decaying spin gap isomers, only possible through conversion-electron spectroscopy of implanted products.

A **0.159(6)% branching ratio** was measured. With deconvolution of electrons spectrum, transition strengths were extracted:  
 **$B(M3) = 0.073(4)$  W.u** and  **$B(E4) = 50(20)$  W.u.**

## Future work

Angular correlations of M3/E4 gamma-ray could be used to confirm mixed nature of transition and sign of mixing.

Aiming to probe more E4 strengths near N = 82 to assess potential apparent enhancement.



Thanks to my collaborators!

**BACKUP FOLLOWS**

# DSSD Correlations & Calibration

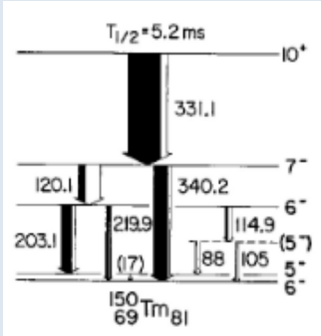

Thresholds on DSSD low ( $\approx 60 \text{ keV}$ ) for possible conversion electrons & (limited)  $\beta$  signals

For measuring conversion electrons of implanted activity, good to have dedicated calibration. External  $\alpha$  source difficult due to dead layer

Strips matched with  $^{133}\text{Ba}$  source, calibrated with internal  $^{150}\text{Tm}$  conversion electrons produced within 1 shift overnight

Decays of Millisecond Isomers in Odd-Odd  $N=81$  Nuclei  $^{146}\text{Tb}$ ,  $^{148}\text{Ho}$  and  $^{150}\text{Tm}^*$

R. Broda<sup>\*,†</sup>, P.J. Daly<sup>†</sup>, J.H. McNeill<sup>\*,\*\*</sup>, Z.W. Grabowski<sup>†</sup>,  
R.V.F. Janssens<sup>†</sup>, R.D. Lawson<sup>†</sup>, and D.C. Radford<sup>\*,\*\*†</sup>  
<sup>†</sup> Purdue University, West Lafayette, Indiana, USA  
<sup>\*\*</sup> Argonne National Laboratory, Argonne, Illinois, USA

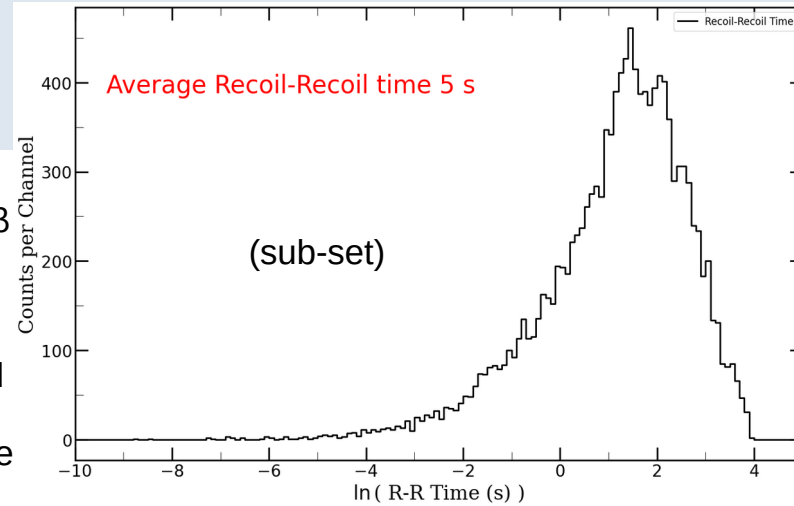
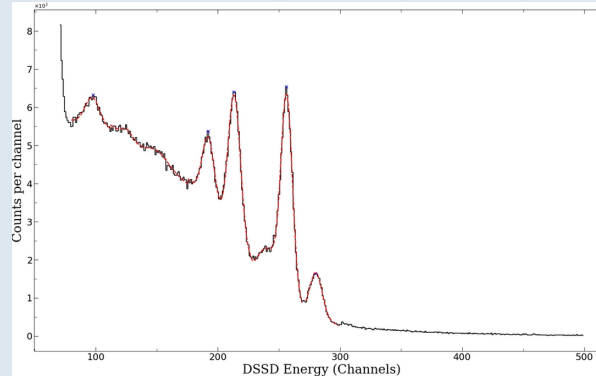
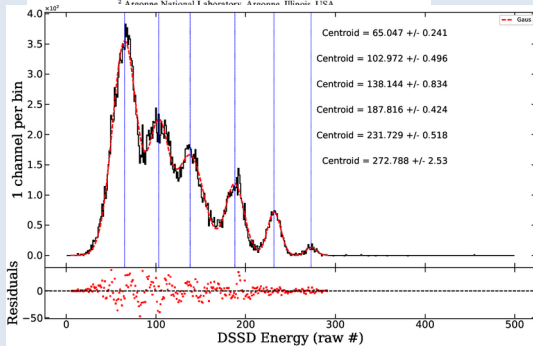

Random recoil rate (R - R) defines max correlation time.

Exponential distribution, average time 5 seconds. Can't correlate well beyond this time after implantation.

# Competing EM Branch: Simulated spectra

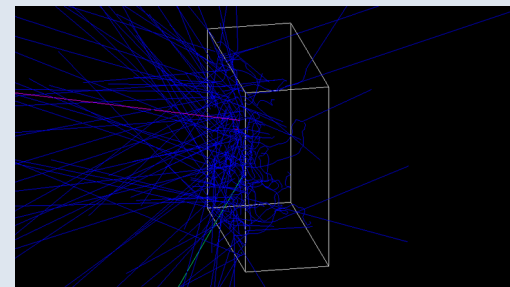
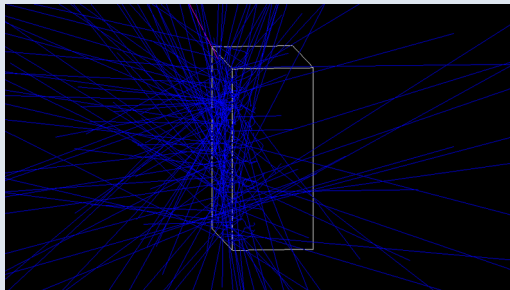
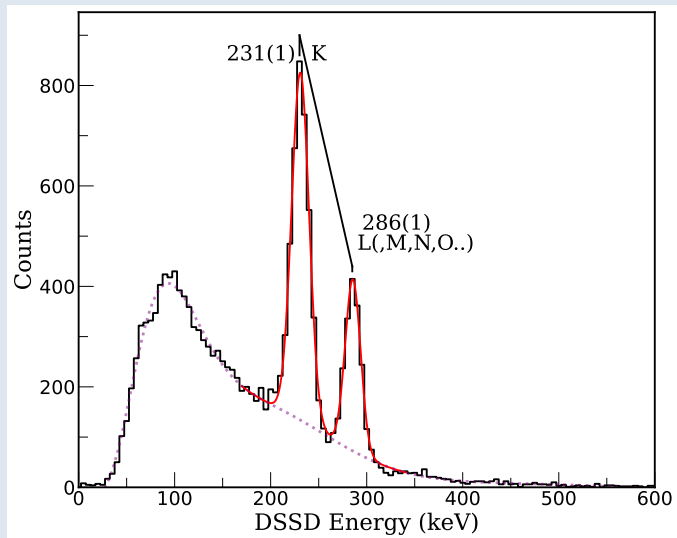

## Measured transition energy

using K:  $231(1) \text{ keV} + 55.3 \text{ keV} = 286.3(1) \text{ keV}$ , using L(M,NO):  **$286(1) \text{ keV}$**

Isomer excitation energy (  $806.7(3) + 684.8(3) + 286(1)$  ) =  **$1778(1) \text{ keV}$**   
Consistent with  **$1776(2) \text{ keV}$**  from  $\alpha$  decays.

**Confirmed by  
NPTool DSSD  
simulation  
(atomic relaxation  
included)**

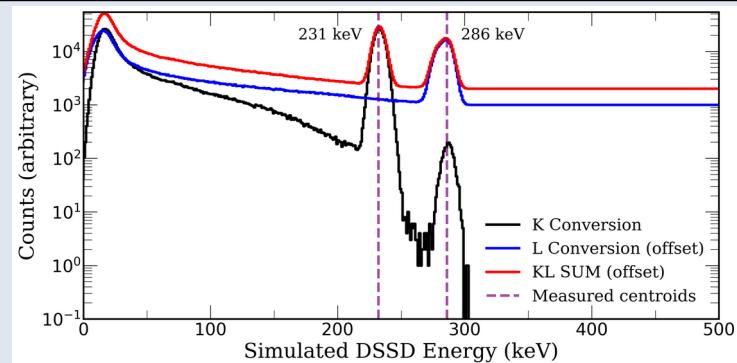

# Evaporation discrimination

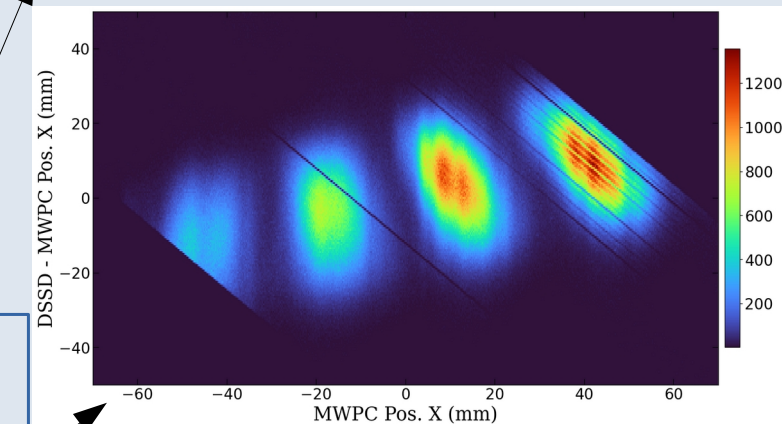
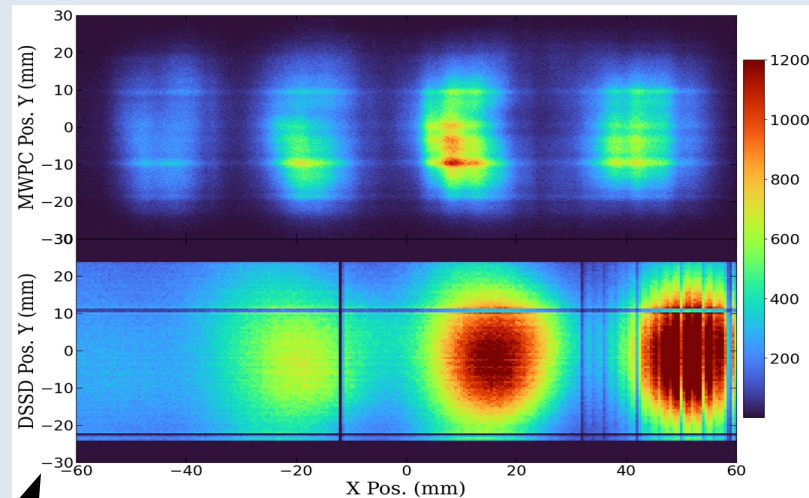
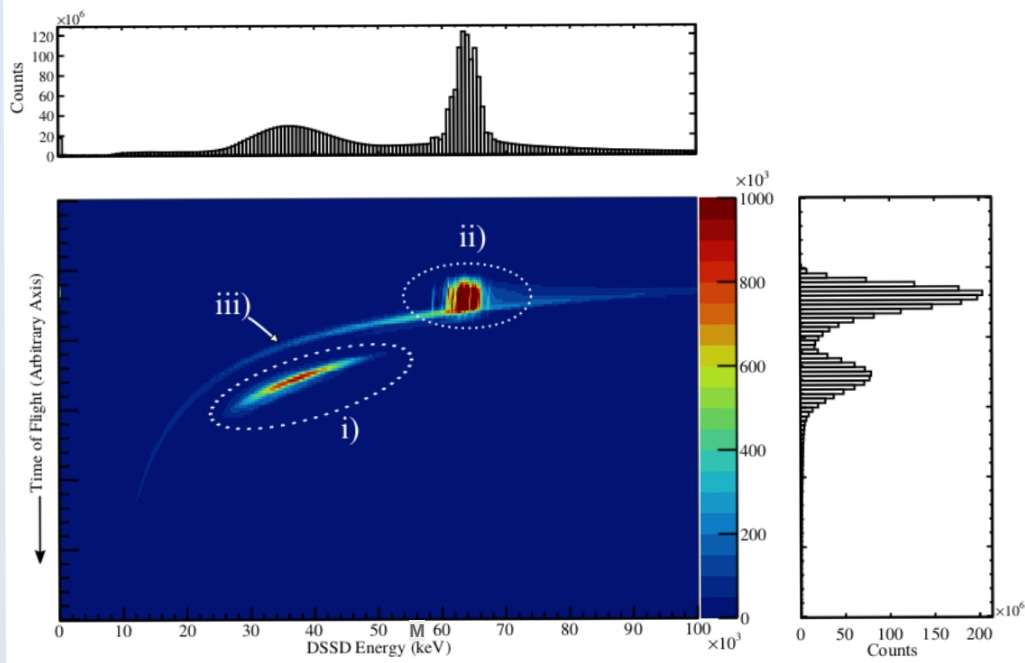

ToF between MWPC and DSSD  
Characteristic implantation energy in Si

$\alpha$  tagged (one mass)

4 charge states

$^{146}\text{Gd}$

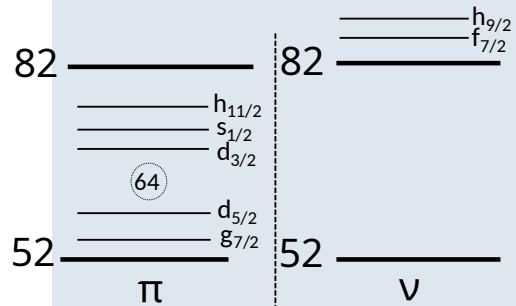
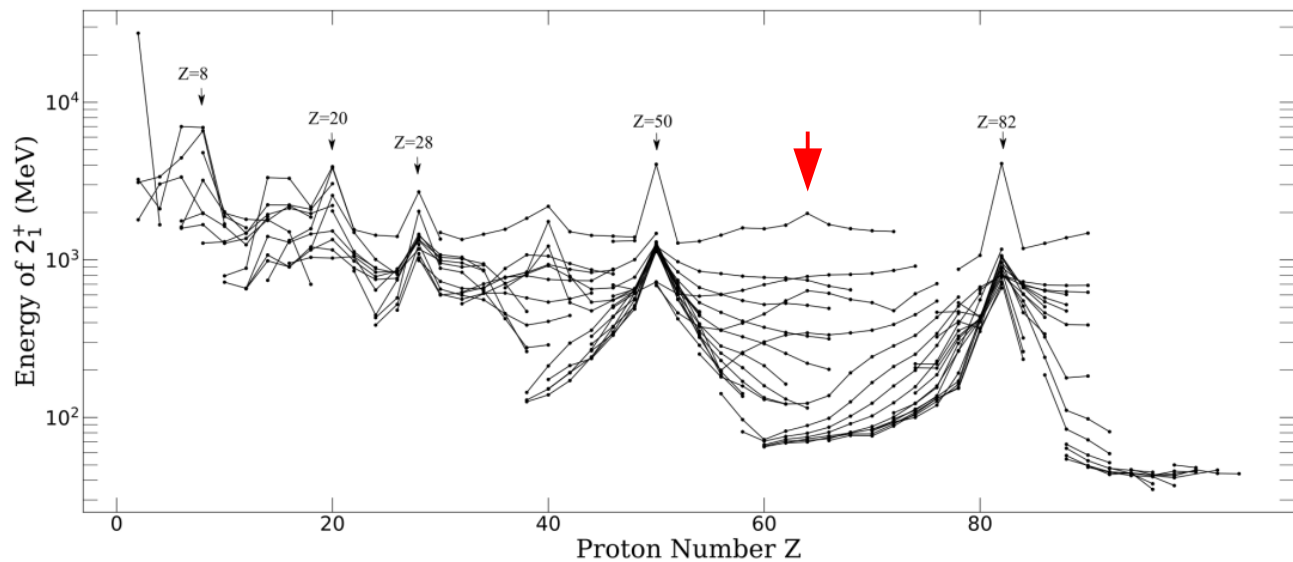

# Heavier N=84 isotones

## Even-even

$8^+$  ( $\nu h_{9/2}$ )<sup>2</sup> states fall below event the  $4^+$  ( $\nu f_{7/2}$ )<sup>2</sup> states at <sup>158</sup>Pt (Z=78) ?

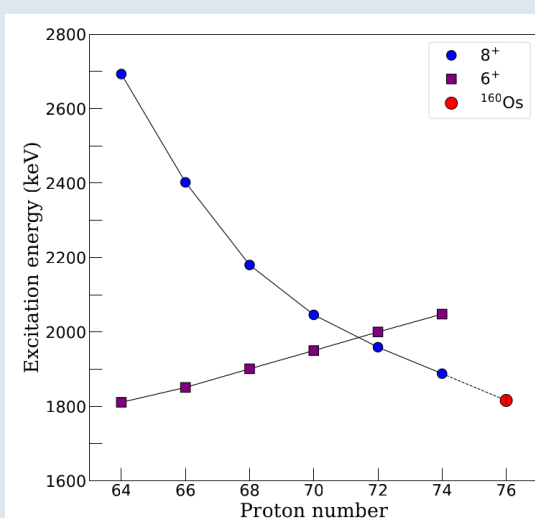
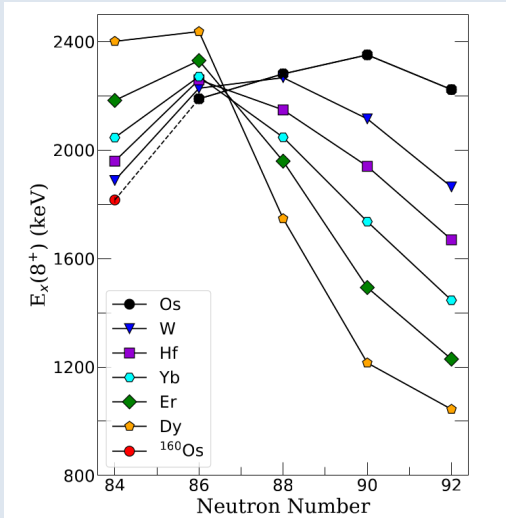

## Odd-even

$25/2^-$  not present in <sup>157</sup>Ta, states should continue to fall in energy. No excited states known in <sup>159</sup>Re (Z = 75).

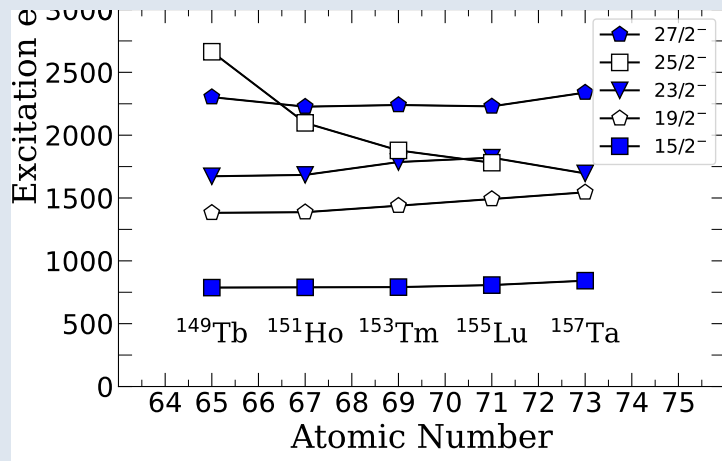

# Experiments with recoil separators at JYFL

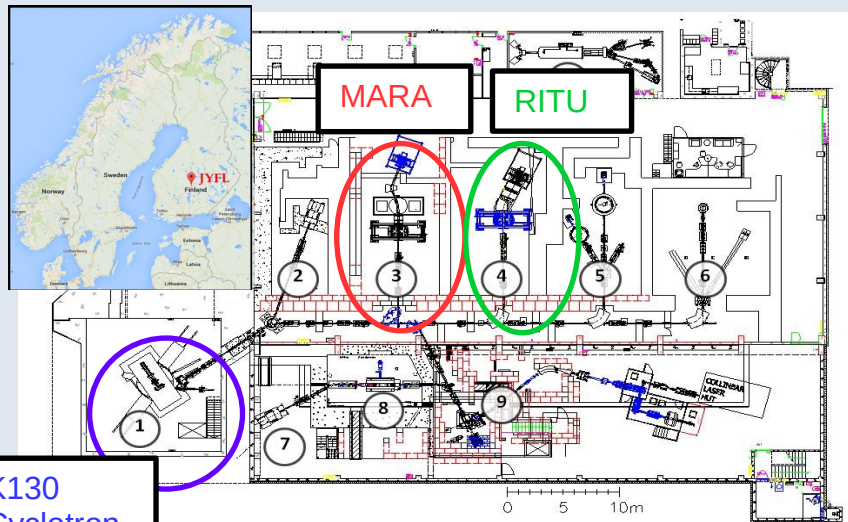

$$E_{\rho_e} = \frac{pv}{q} \approx \frac{2E_k}{q}$$

$$B\rho_B = \frac{p}{q} \approx \frac{\sqrt{2E_k m}}{q}$$

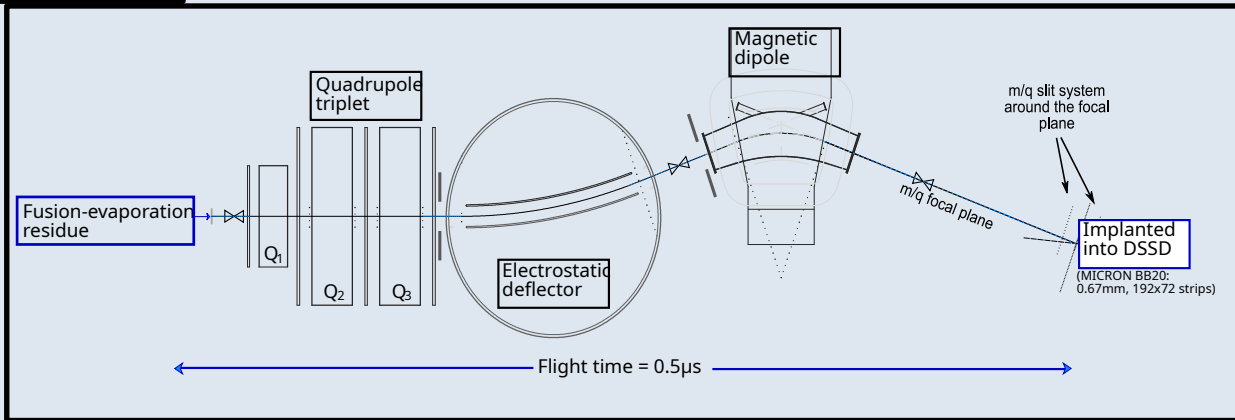
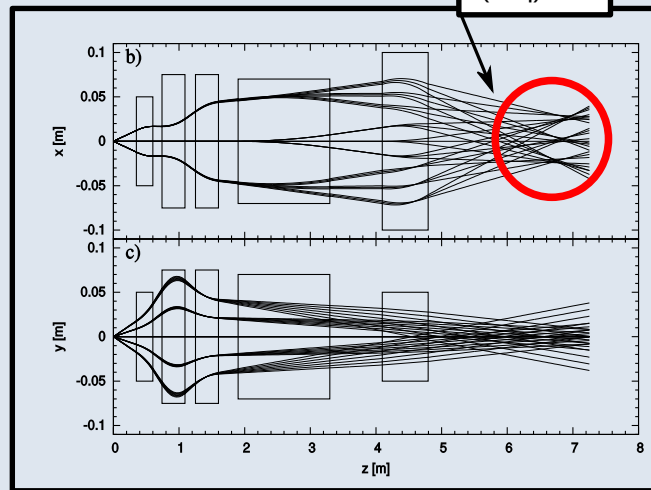

200 MeV Recoil =>  
v/c = 0.05

# Rebinned electron deconvolution

