

Identification of excited states in ^{114}Ba using recoil-decay tagging

Ben Hogg

IoP Nuclear Physics Conference 2025
23rd – 25th April 2025



Reflection-asymmetric nuclei

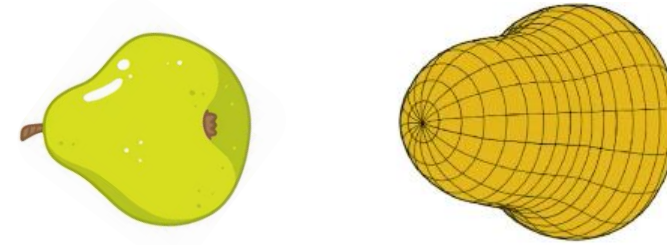

Octupole-deformed nucleus (a_{30})

Characteristic properties:

- Interleaving opposite-parity energy levels in even-even nuclei
- Parity doublets in odd-mass nuclei
- Enhanced E1 transitions
- Large E3 transition probabilities

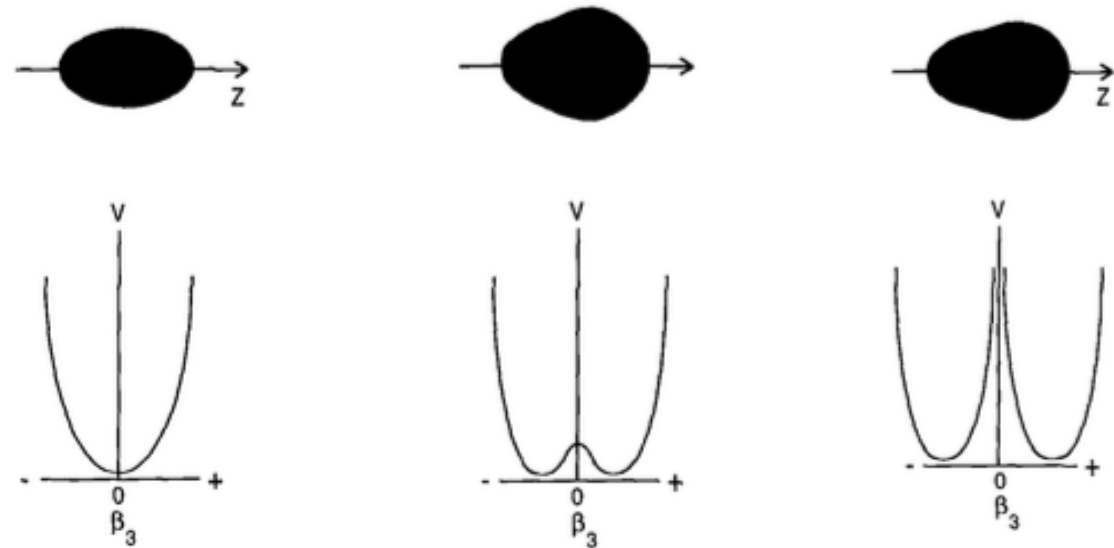

Vibrational octupole Transitional octupole Rigid octupole

Regions of octupole deformation in even-even nuclei

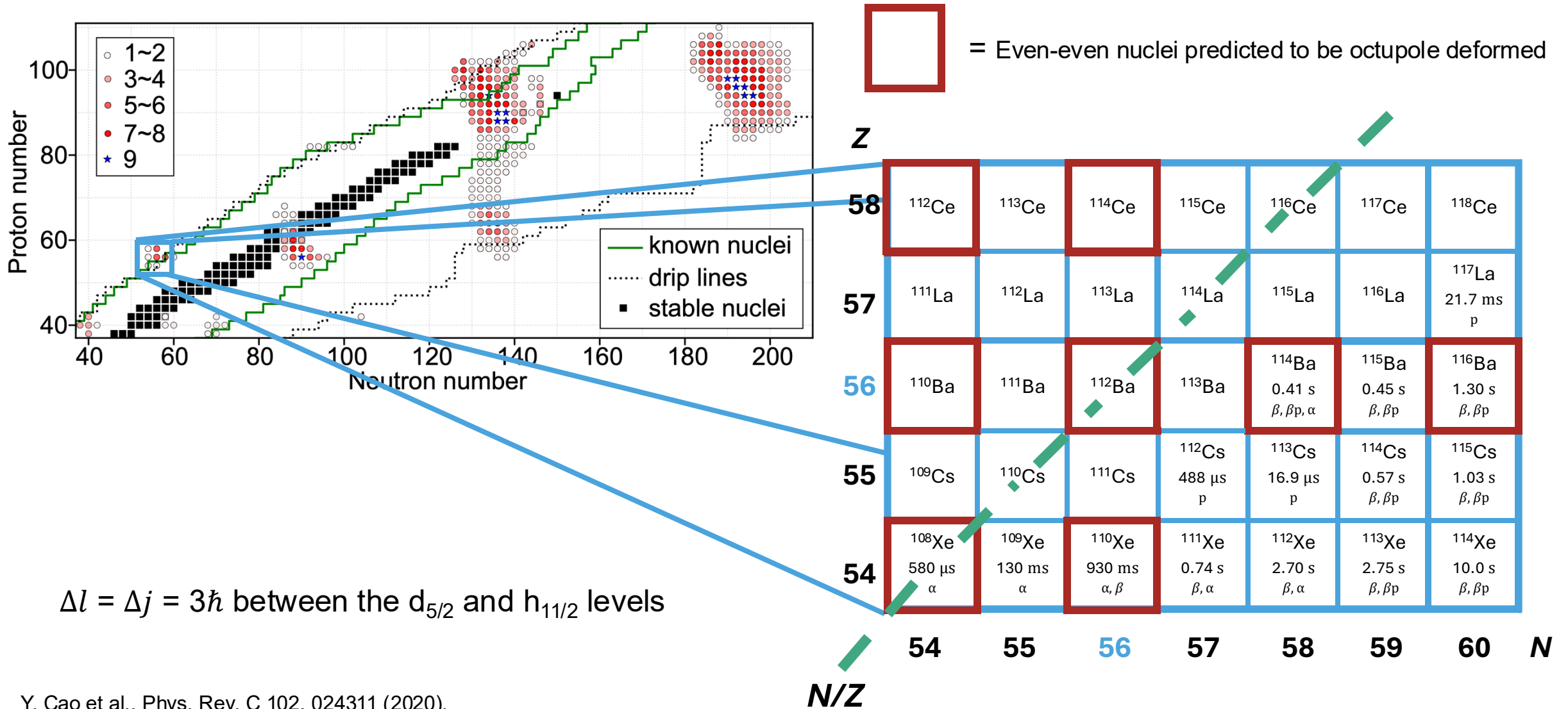

Predicted octupole correlations in ^{114}Ba

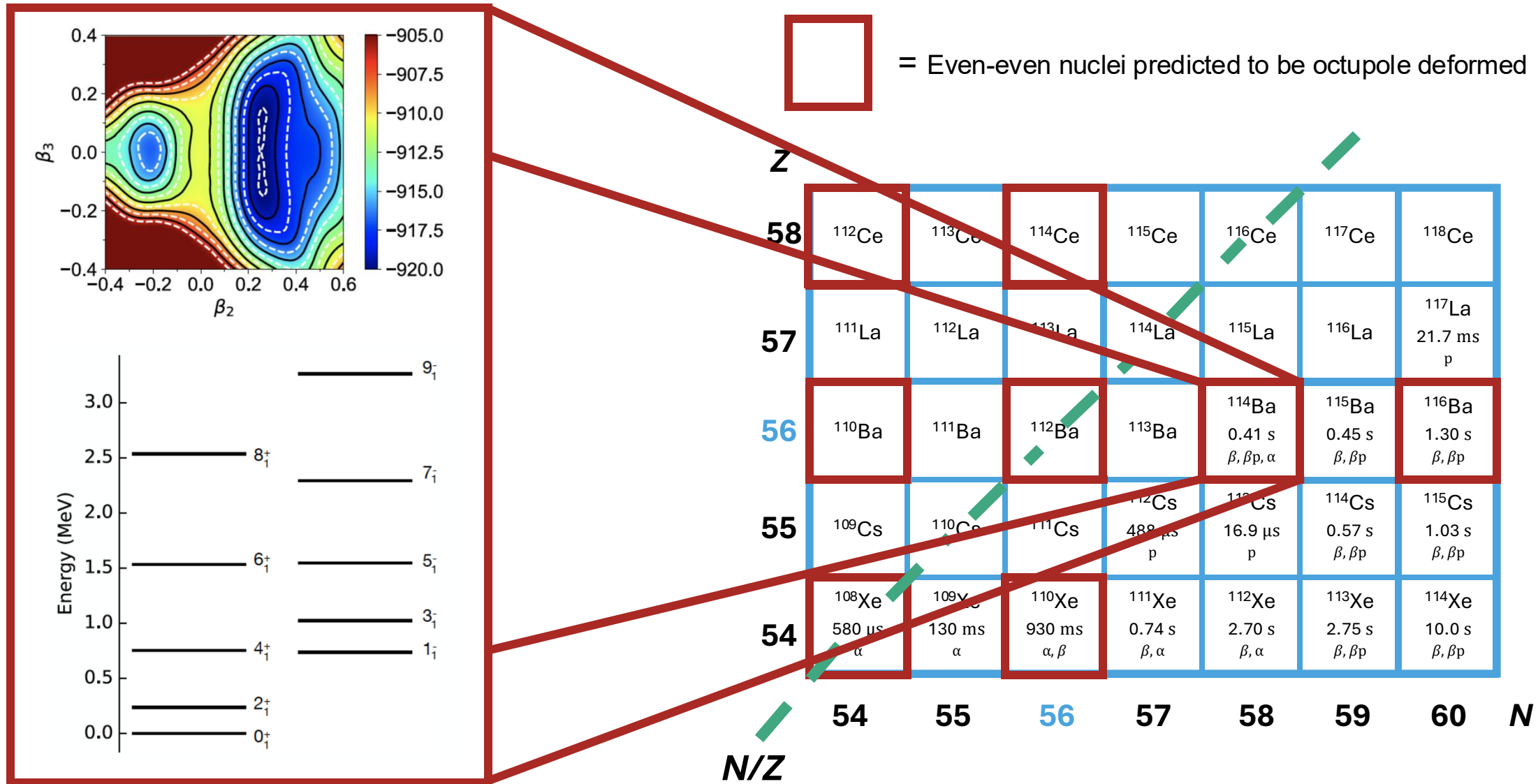

Studies of neutron-deficient isotopes near ^{114}Ba

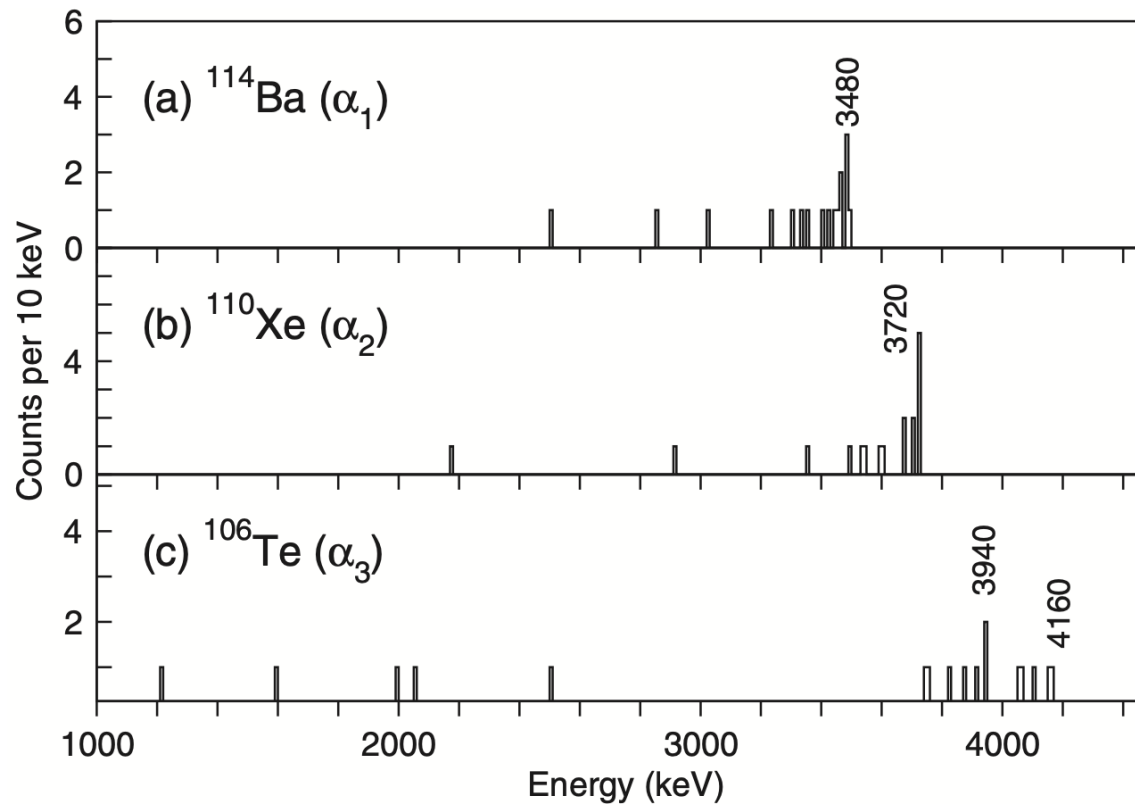
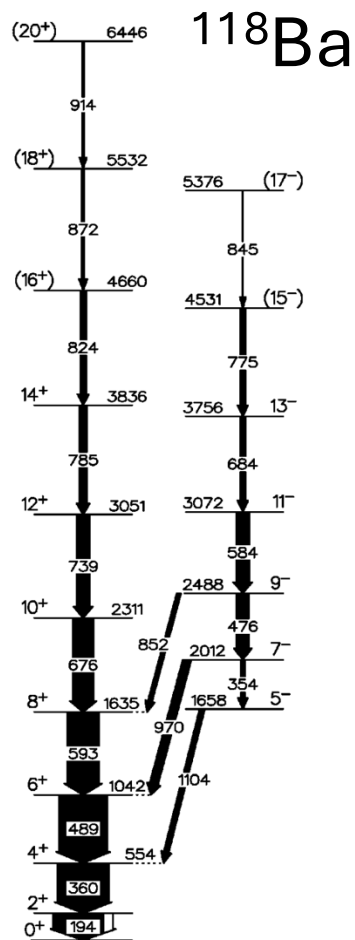

Experimental details: MARA, Jurogam and JYTube

24 clover and
15 n-type Ge
detectors

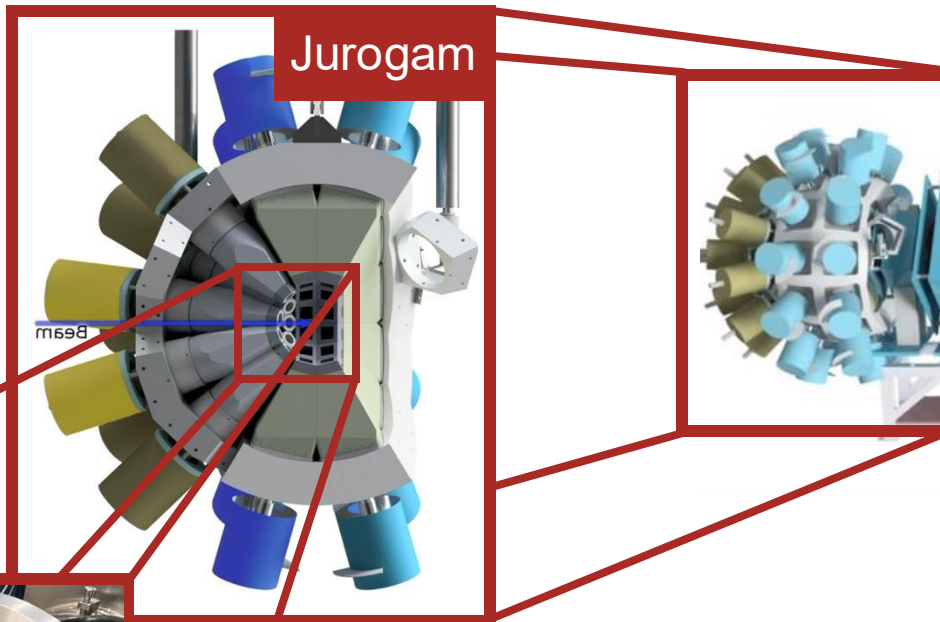

Jurogam

MARA separator

Decay station



JYTube

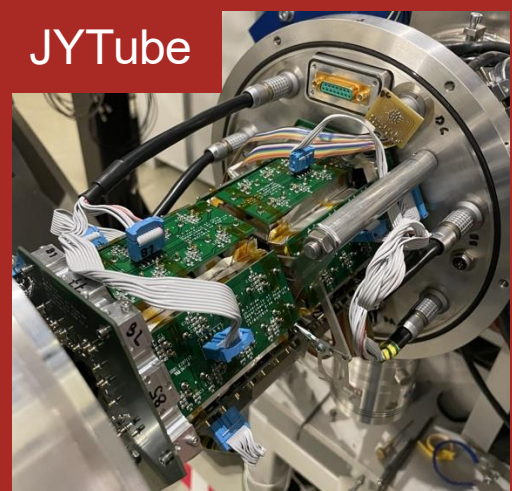

120 plastic scintillators

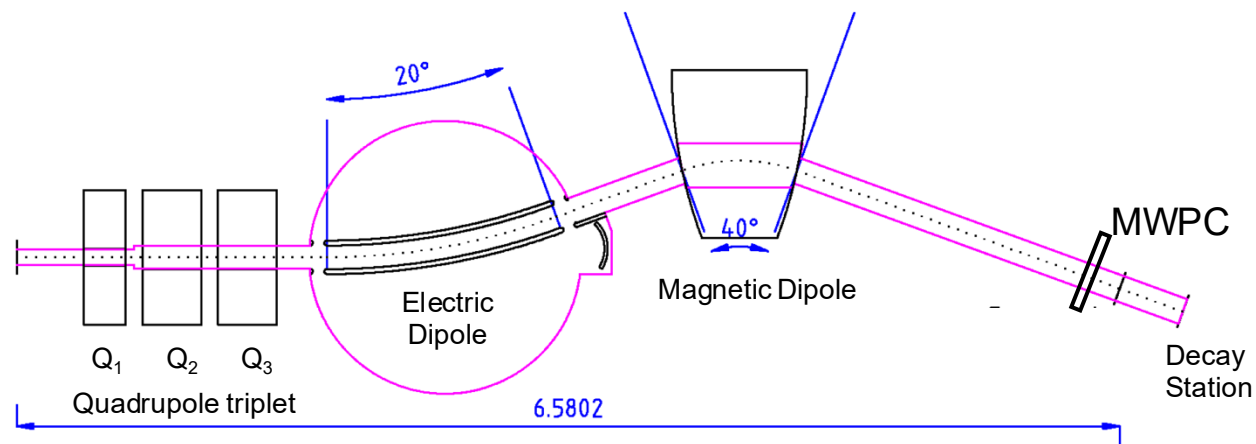

Experimental details: MARA mass separation

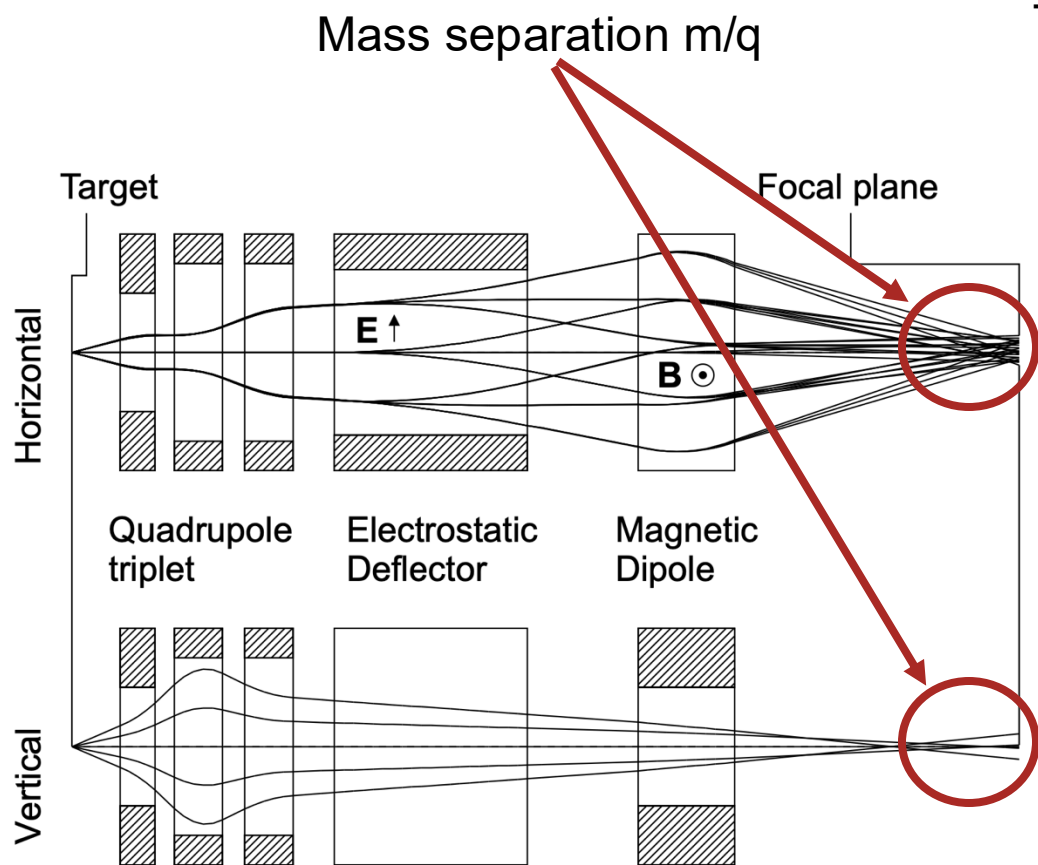

J. Saren et al., NIM-B 266, 4196 (2008)

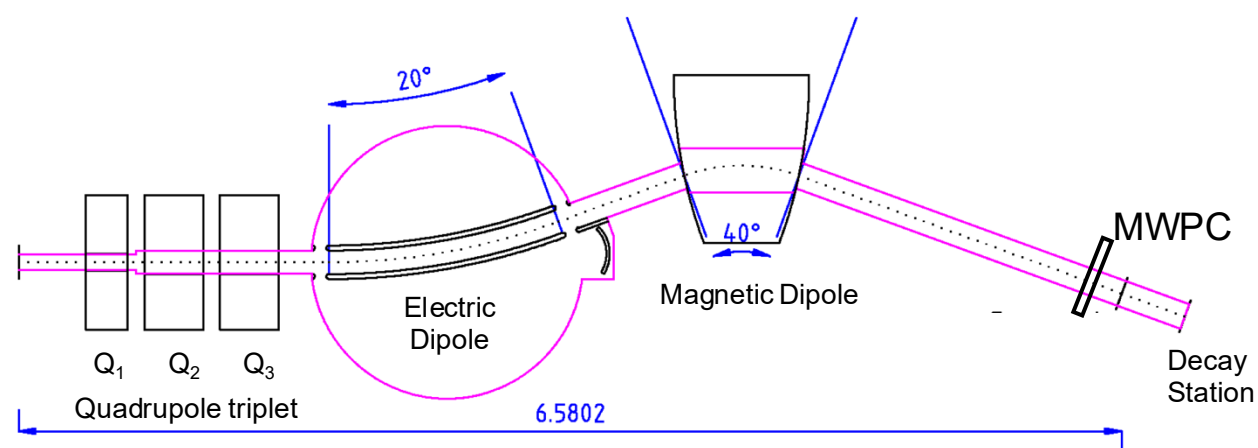

P. Ruotsalainen, Gamma-ray spectroscopy employing JUROGAM 3 and MARA, NuSpin 2019. J. Uusitalo et al., Acta Phys. Pol. B 50, 319 (2019)

Experimental details: MARA mass separation

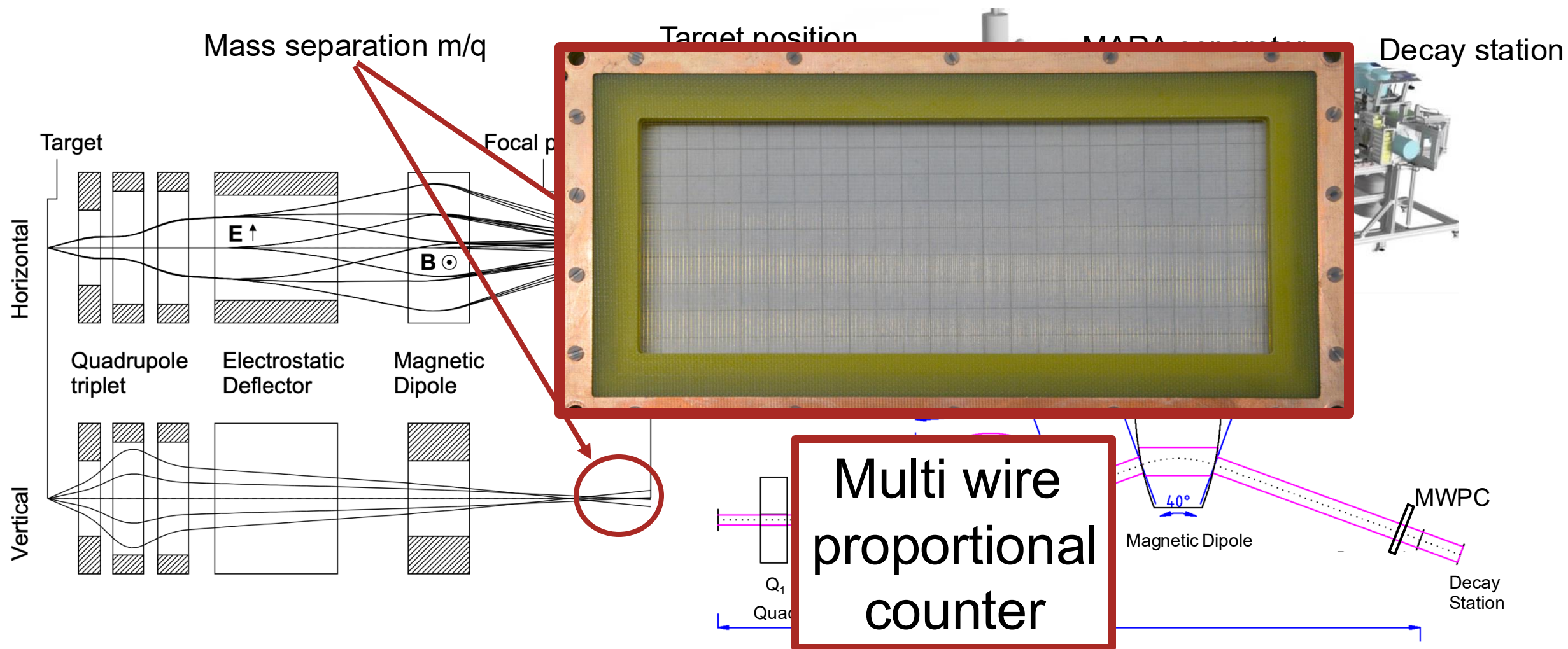

J. Saren et al., NIM-B 266, 4196 (2008)

P. Ruotsalainen, Gamma-ray spectroscopy employing JUROGAM 3 and MARA, NuSpin 2019. J. Uusitalo et al., Acta Phys. Pol. B 50, 319 (2019)

Experimental details: MARA mass separation

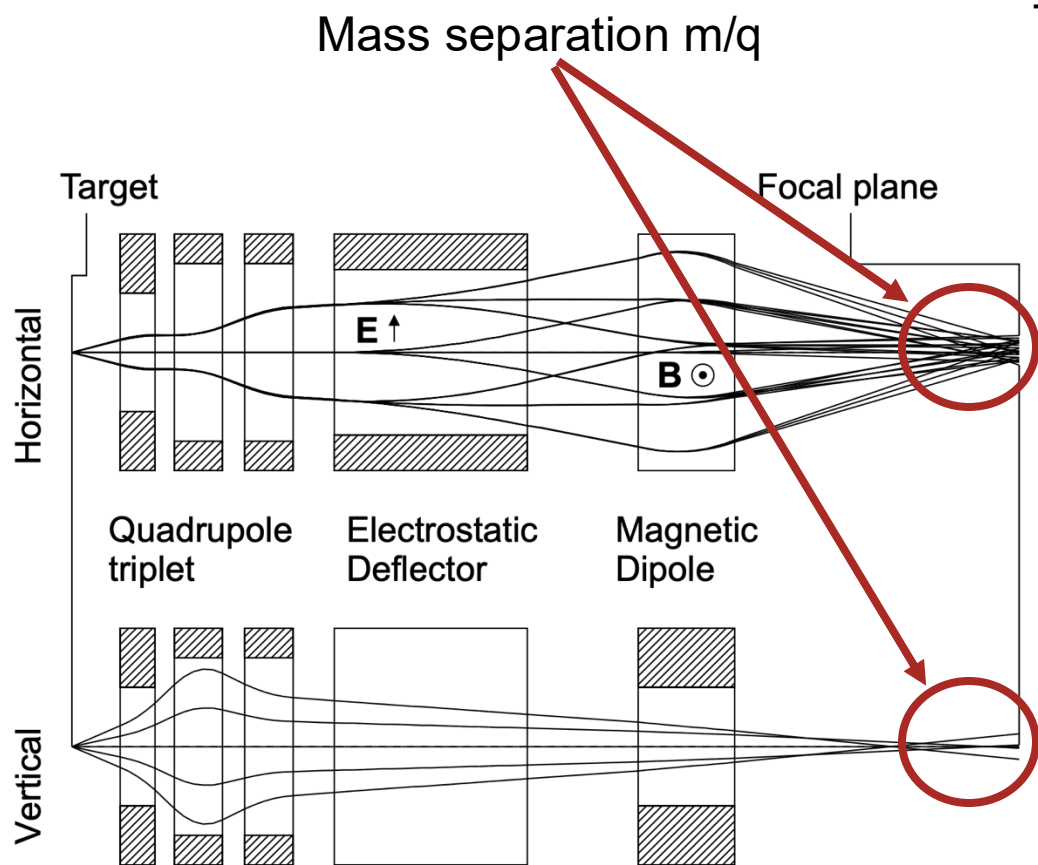

J. Saren et al., NIM-B 266, 4196 (2008)

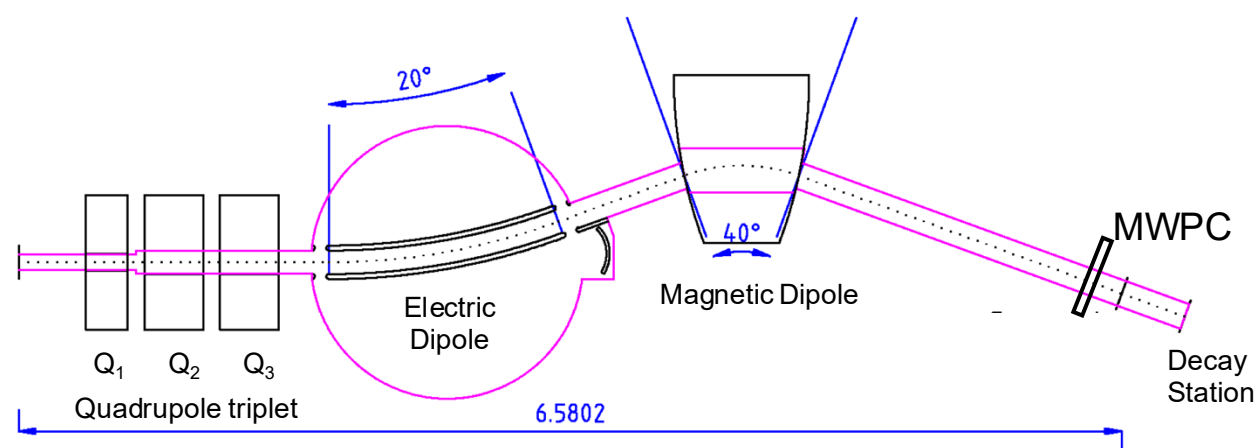

Experimental details: decay station

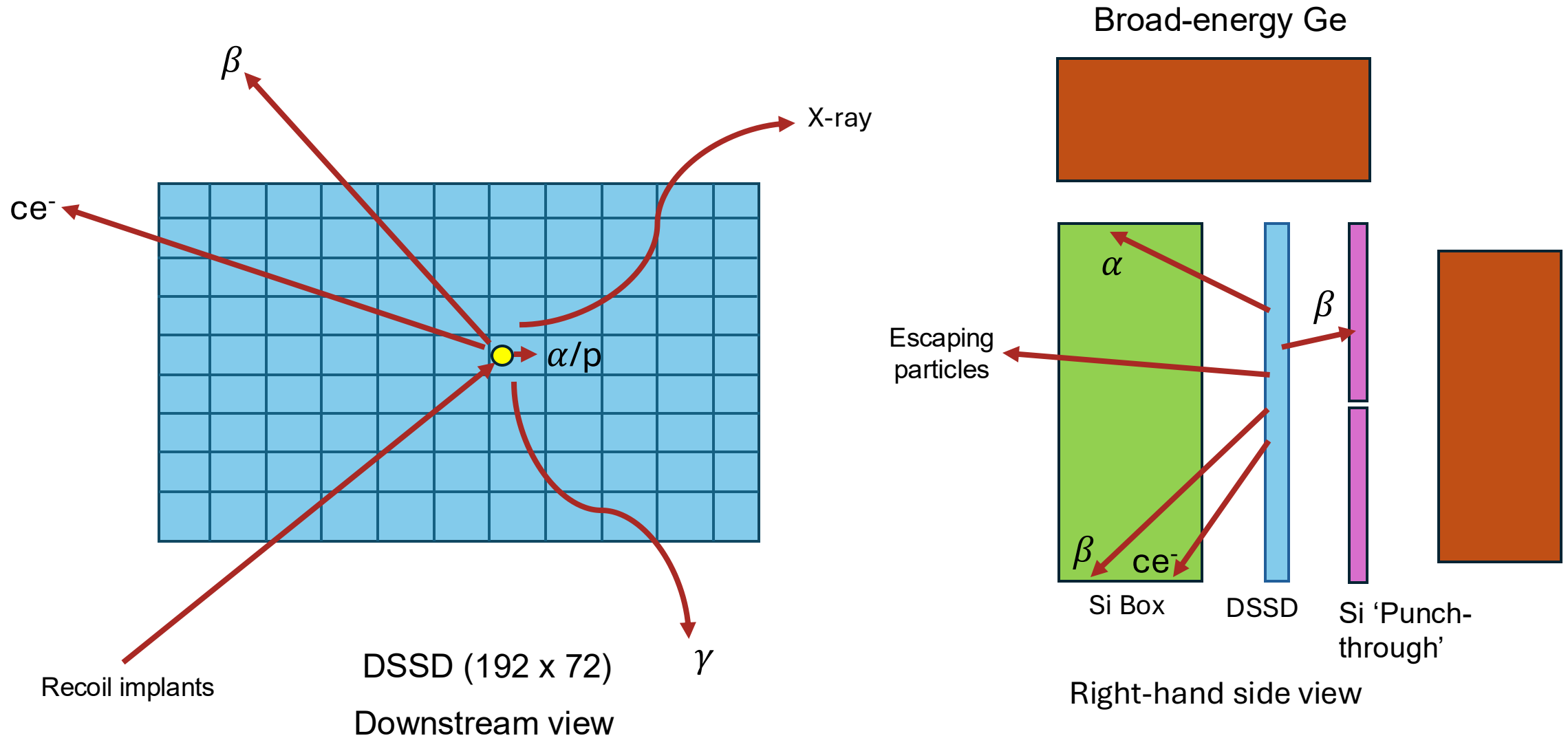

Experimental details: decay station

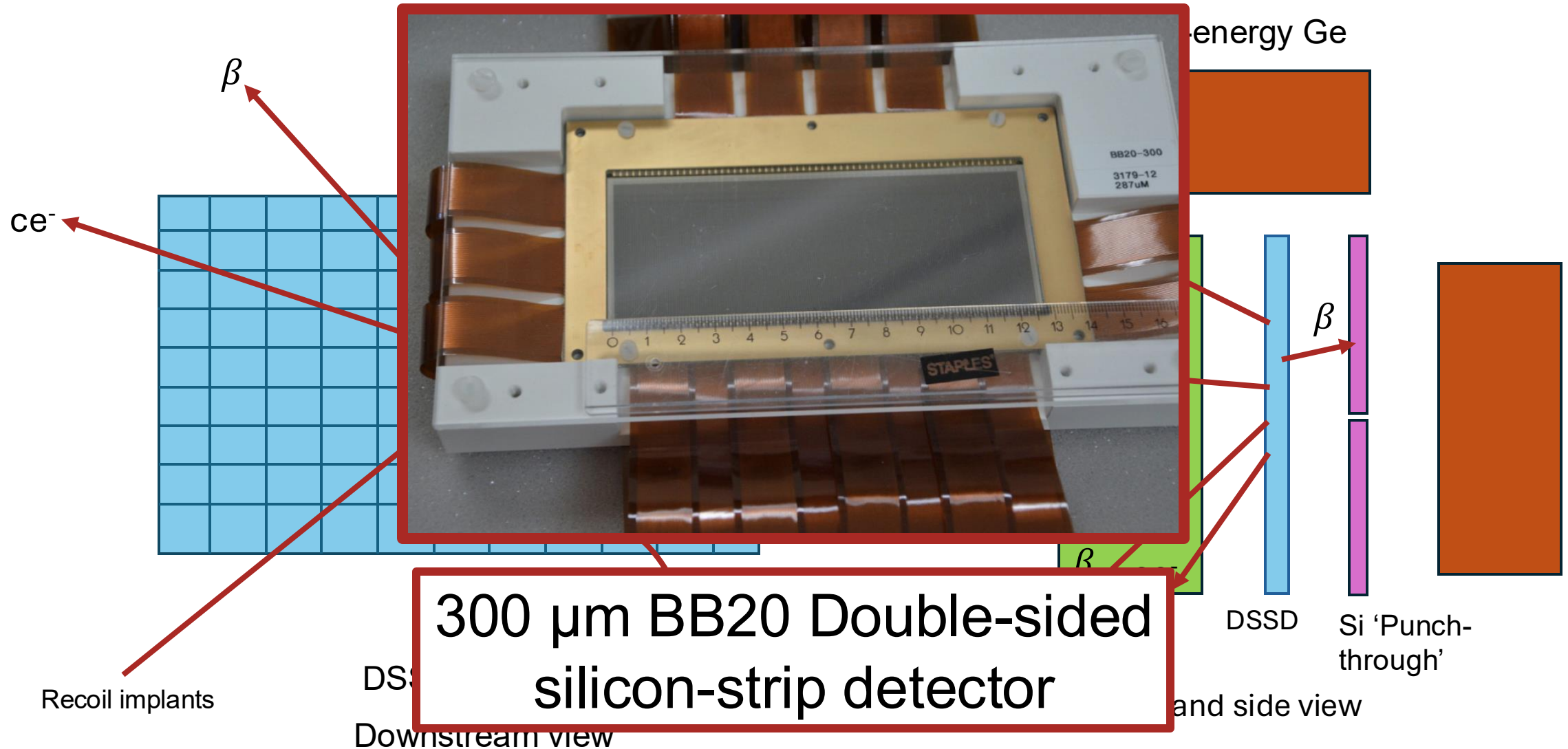

Experimental details: decay station

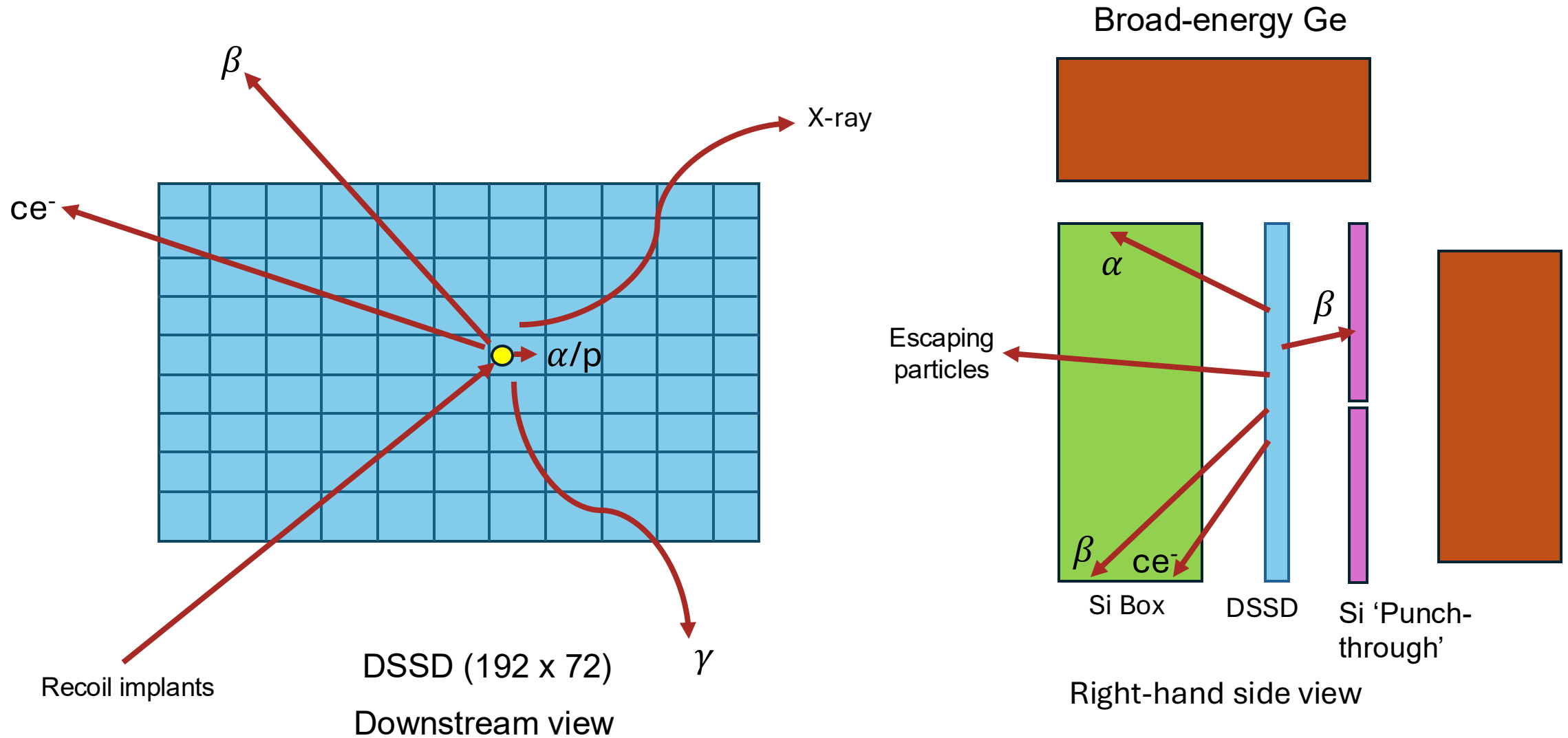

Experimental details: decay station

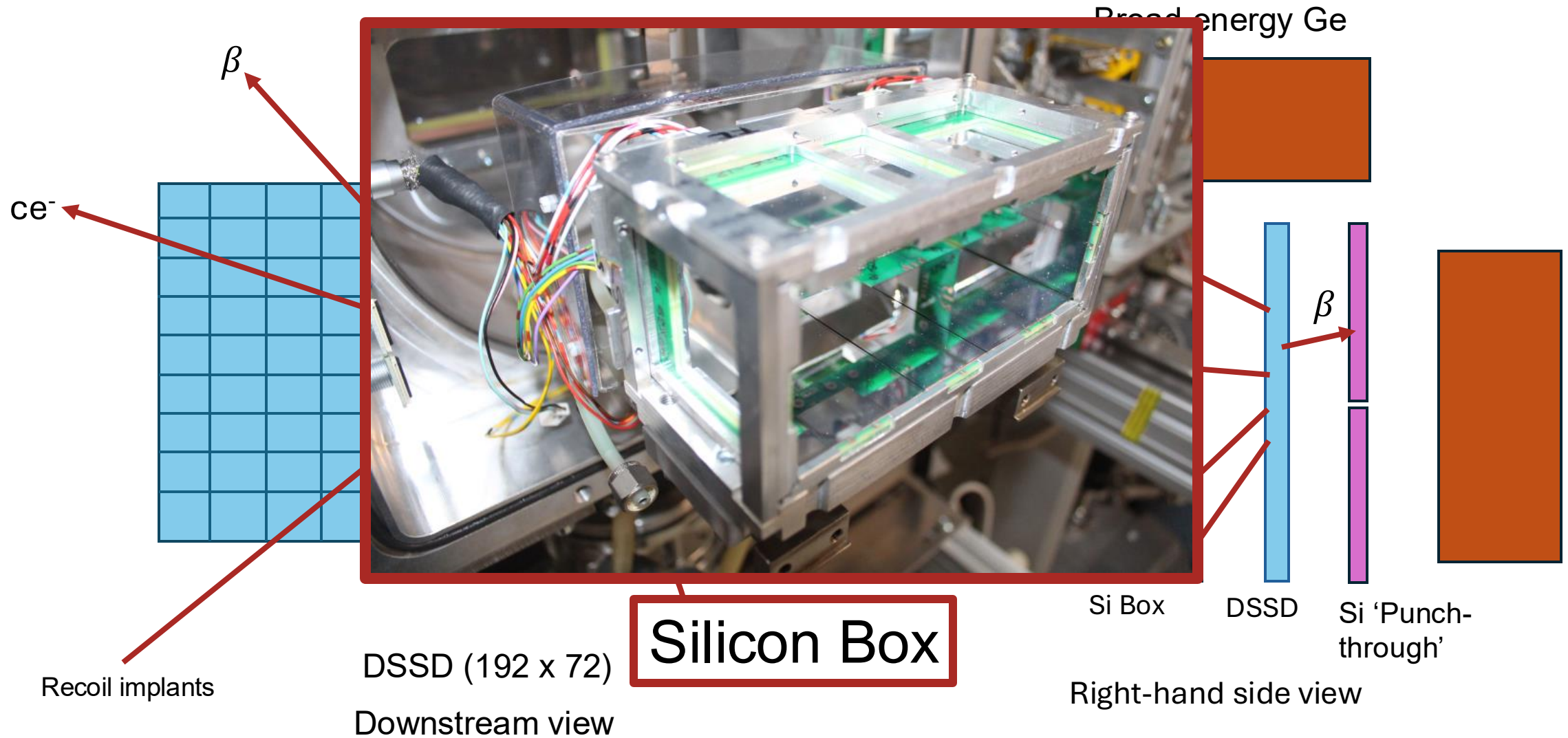

Experimental details: decay station

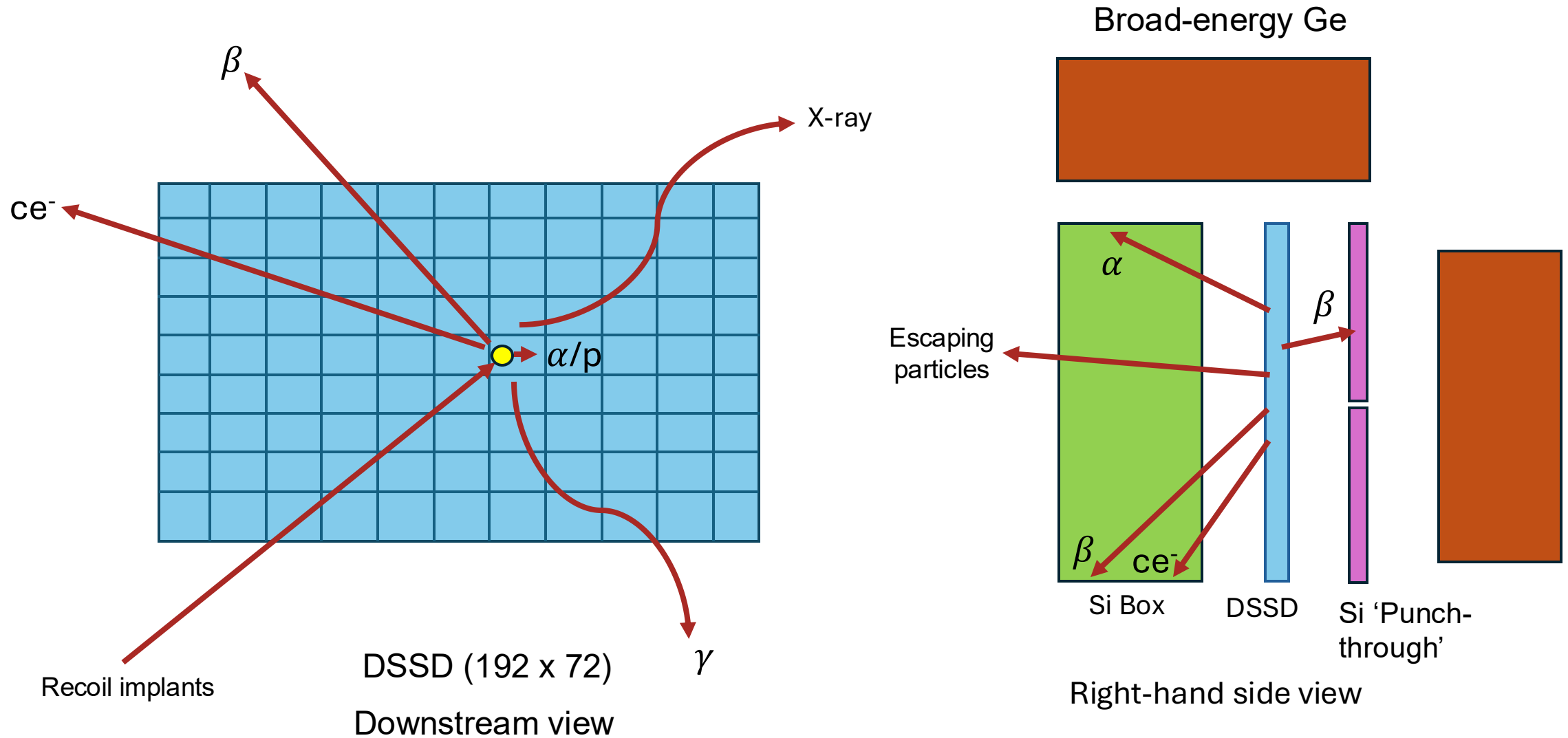

Experimental details: decay station

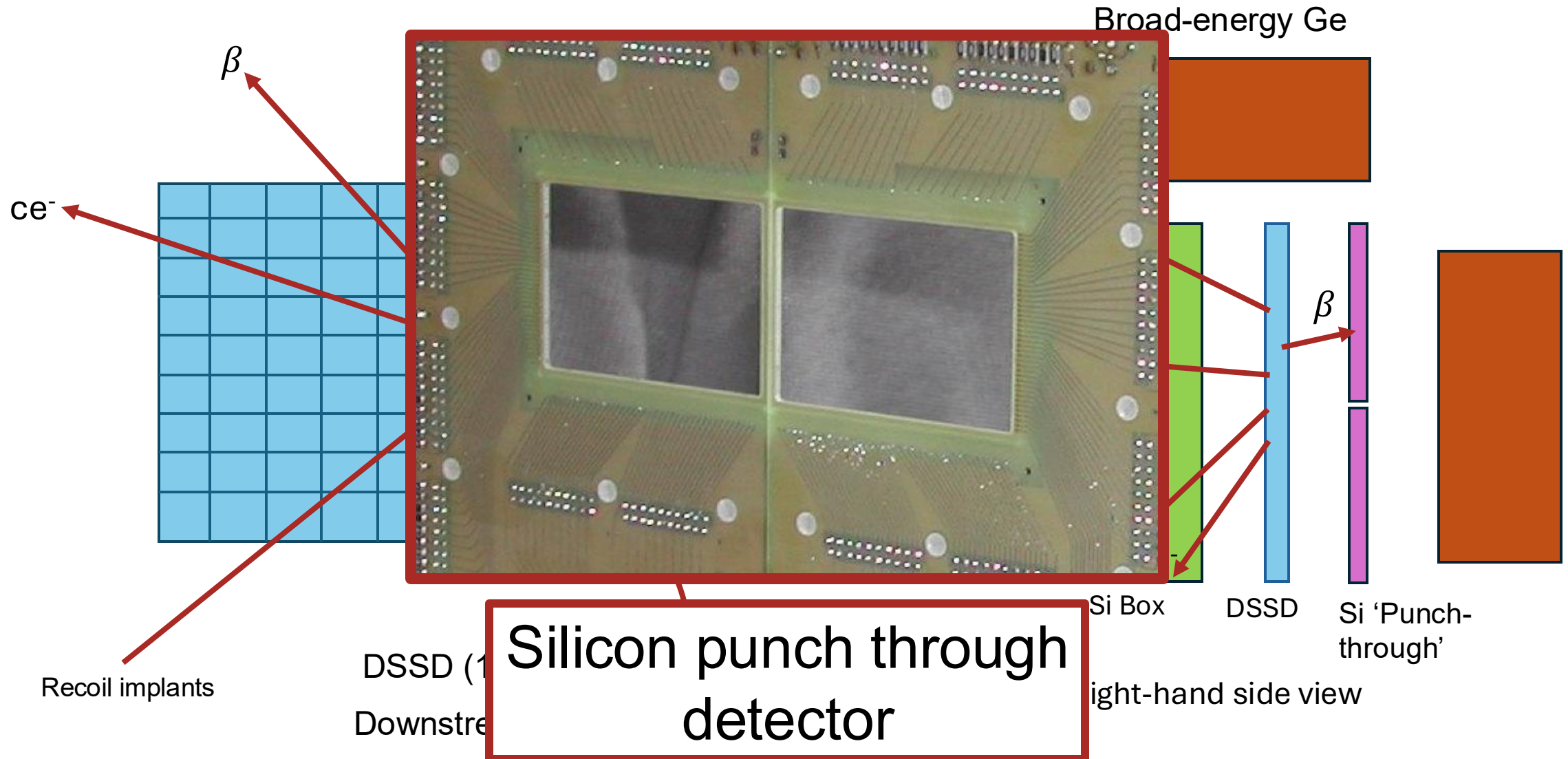

Experimental details: decay station

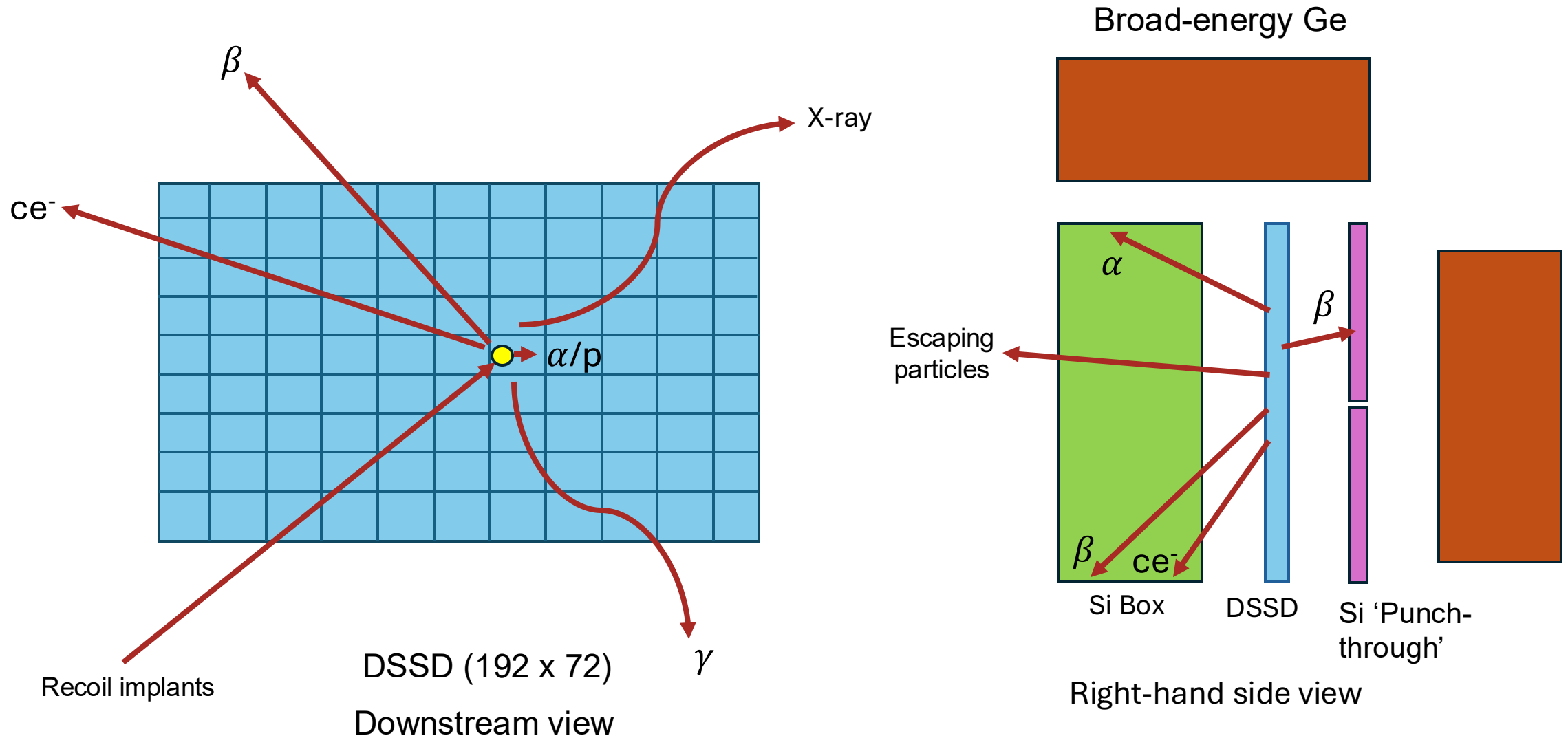

Recoil-decay tagging

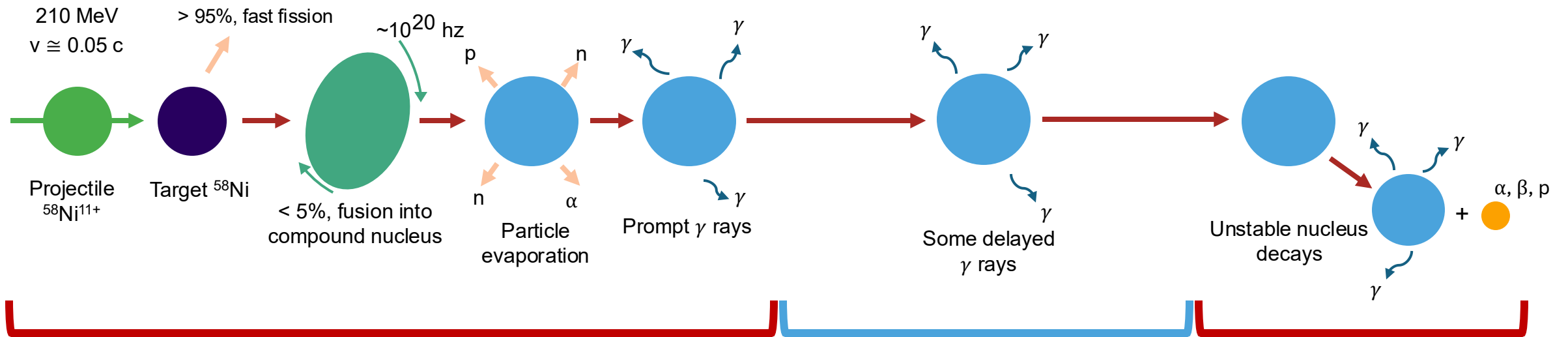

ToF ~ few ns

ToF ~ 1 μs

Decay time: μs - seconds

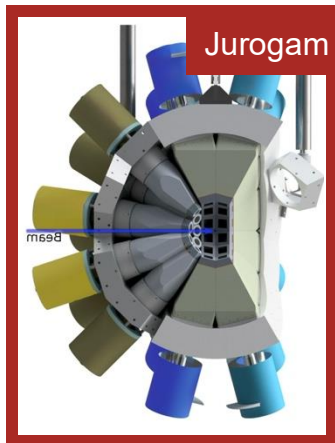

+

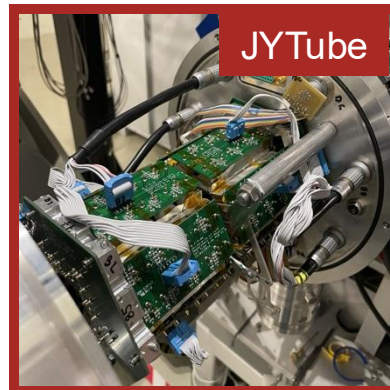

Preliminary analysis: reaction products

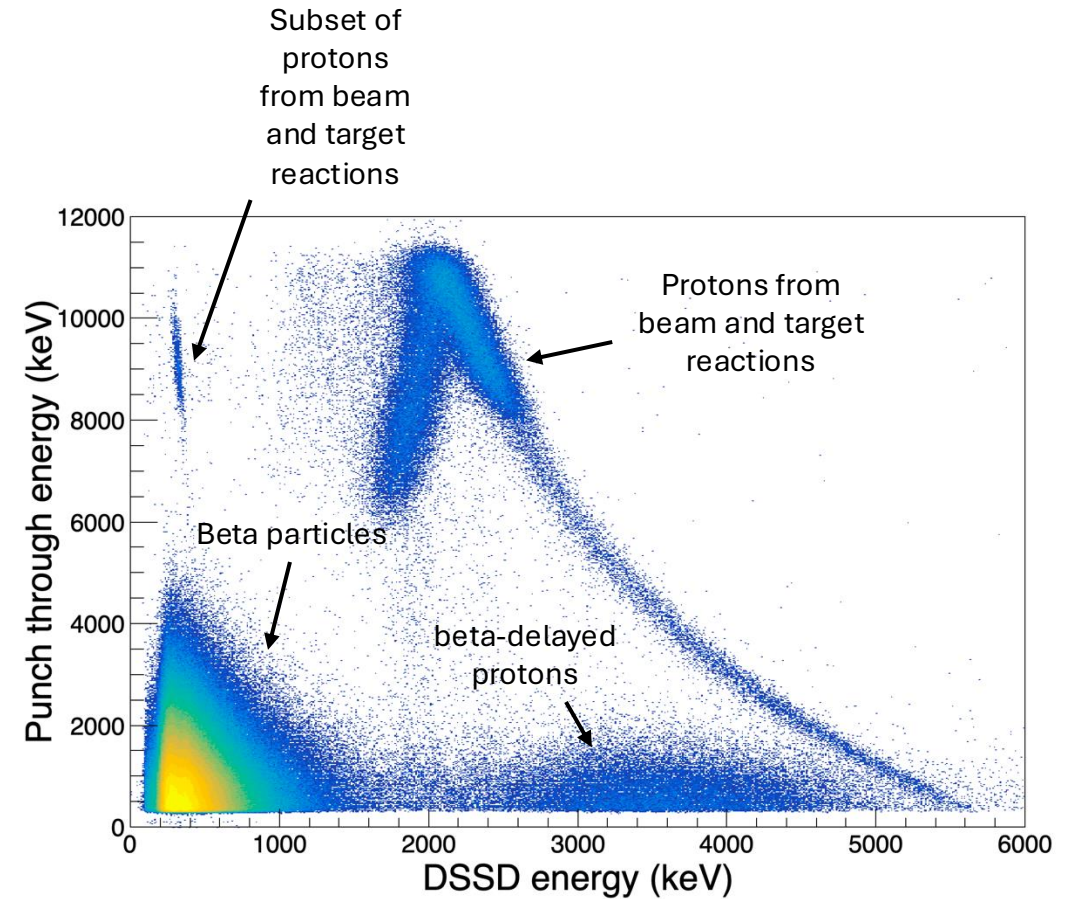
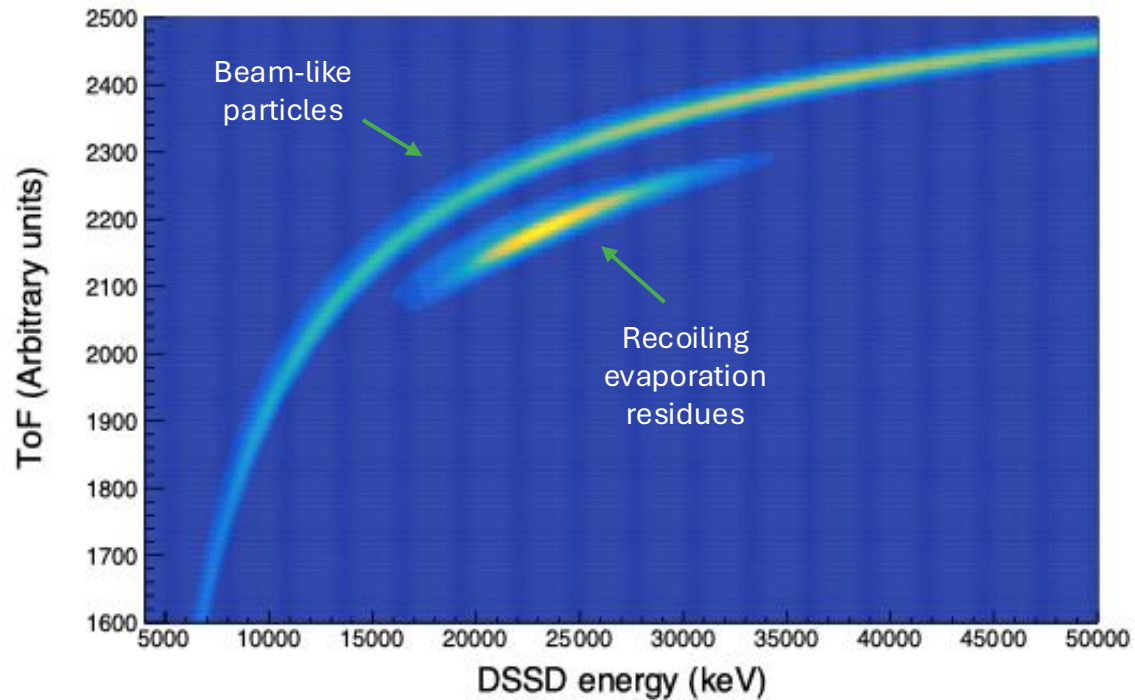

Preliminary analysis: mass-to-charge ratio

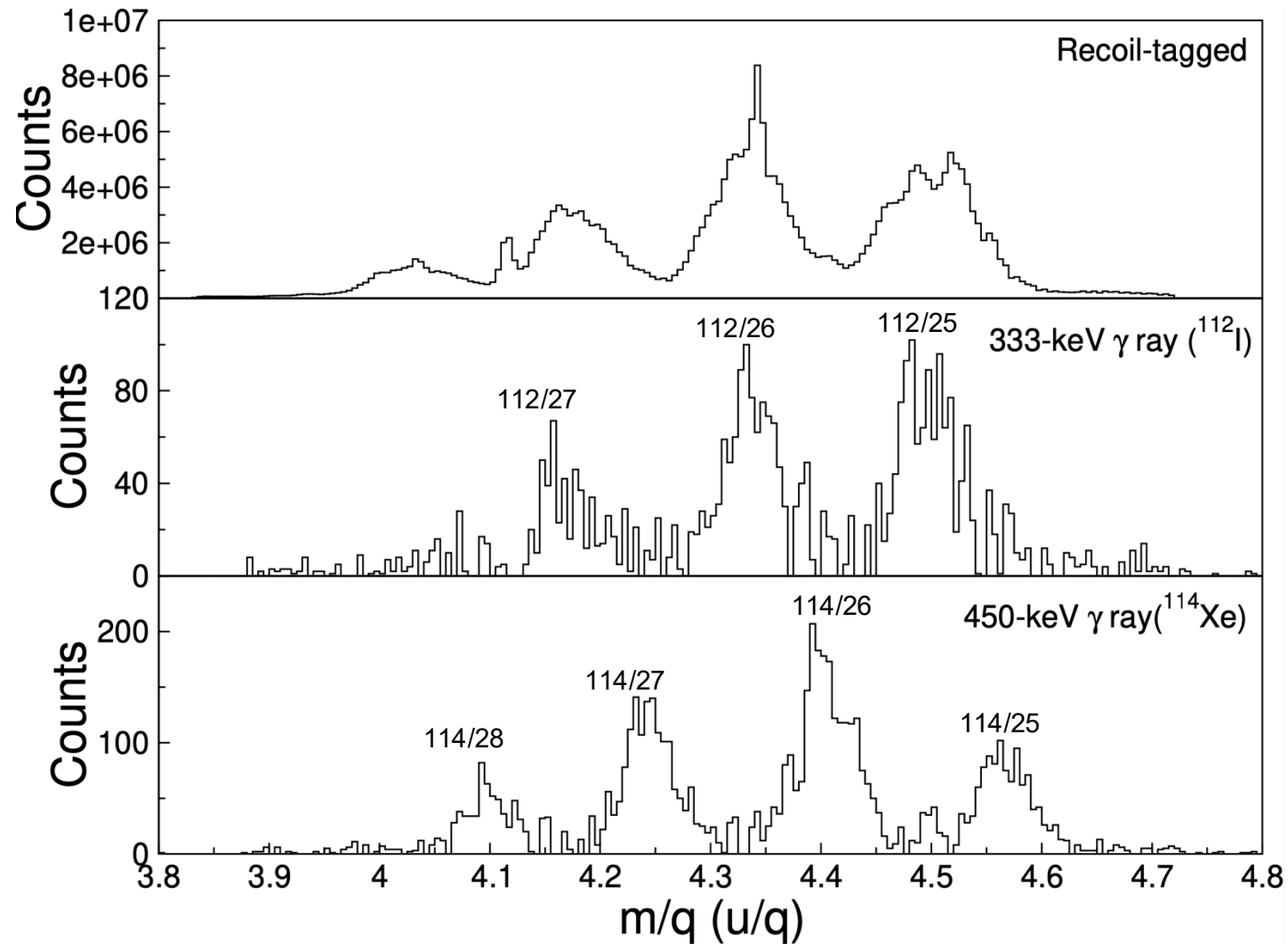

Preliminary analysis: presence of ^{114}Ba

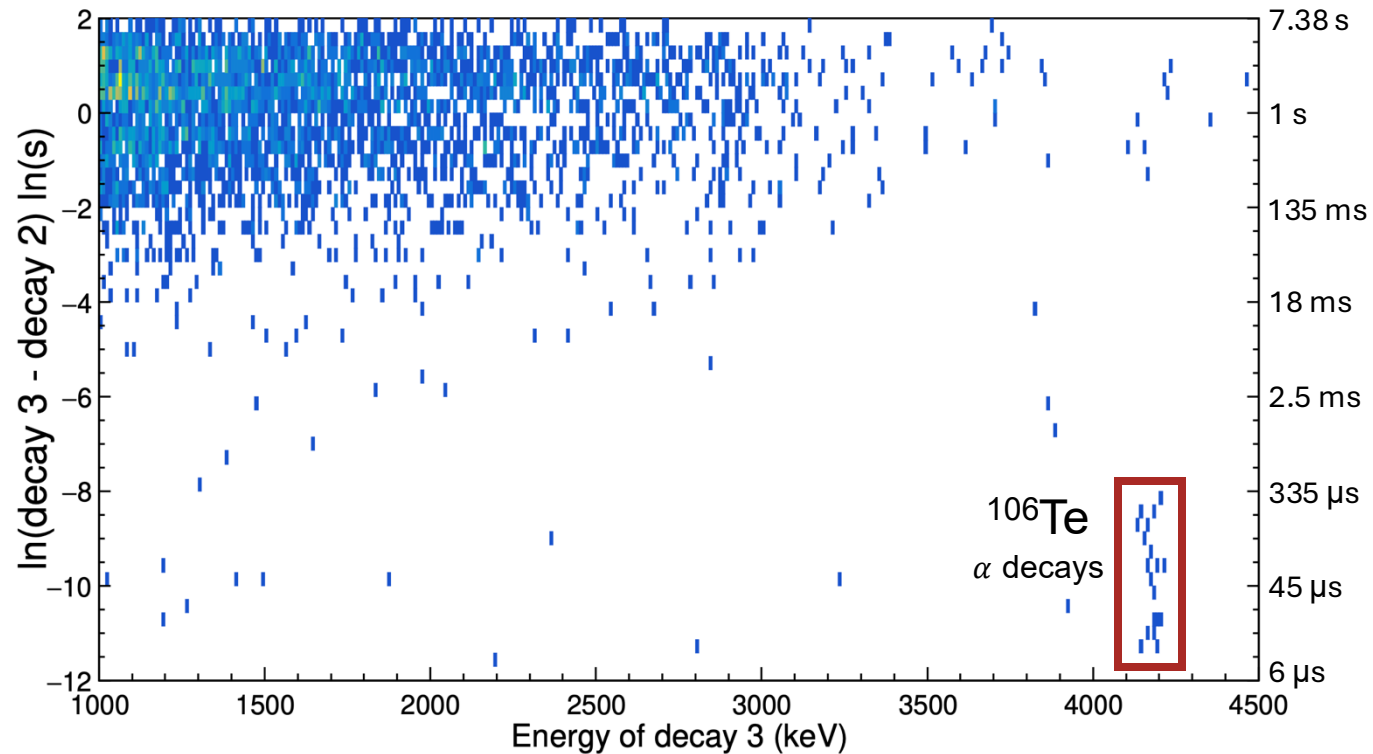
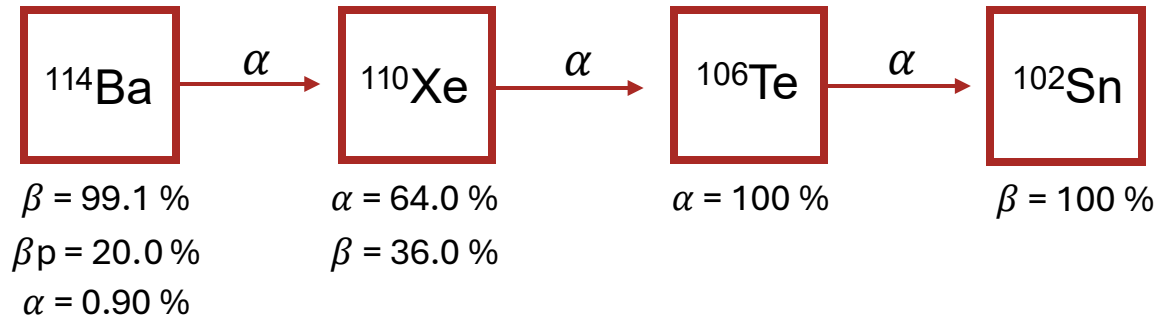

Acknowledgements and summary

B. J. M. Hogg¹, A. Illana², J. J. Valiente Dobon^{3,5}, J. F. Smith¹,
P-A. Aden⁴, K. Auranen⁴, H. Ayatollahzadeh¹,
G. B. Petrisor⁶, J. Benito², V. Bogdanoff⁴, N. S. Bondili¹,
A. D. Briscoe⁷, C. Cassells¹, R. Chapman¹, J. Curry⁶,
F. Galtarossa⁵, A. Gottardo⁵, T. Grahn⁴, P. T. Greenlees⁴,
R. Guaman³, H. Joukainen⁴, J. M. Keatings¹, H. Kokkonen⁴,
N. Landsman⁴, D. Lazzaretto⁴, D. Mengoni^{5,9}, J. Monago²,
D. O'Donnell¹, J. Ojala⁴, J. Pakarinen⁴, J. Pellumaj⁵,
X. Pereira-Lopez⁸, P. Rahkila⁴, P. Ruotsalainen⁴, J. Sarén⁴,
M. Scheck¹, P. Spagnoletti⁷, K. Spohr^{1,6}, D. Stamaccioni^{5,9},
C. Sullivan⁷, E. Uusikylä⁴, J. Uusitalo⁴, P. Vicente², R. Perez³,
G. García², R. Nicolás⁵

1. University of the West of Scotland | 2. Universidad Complutense de Madrid
3. Instituto de Física Corpuscular, University of Valencia | 4. University of Jyväskylä
5. Istituto Nazionale Fisica Nucleare | 6. Extreme-Light Infrastructure, Bucharest
7. University of Liverpool | 8. Institute for Basic Science, Daejeon
9. University of Padua

Extra: ^{113}Cs , sample of RDT

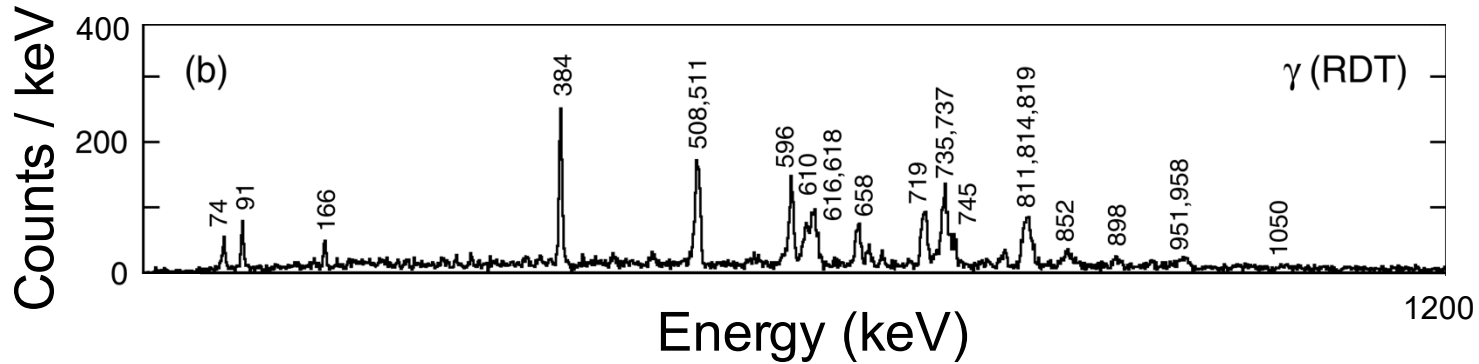

P. T. Wady et al. *Physics Letters B* 740 243-249 (2015)

$^{58}\text{Ni}(^{58}\text{Ni}, p2n)^{113}\text{Cs}$ $E_{\text{beam}} = 230 \text{ MeV}$
target thickness = 500 ug/cm^2 $I_{\text{beam}} \approx 1.5 \text{ pA}$

Total data: ~390 GB.

Recoil-proton tagged: 969(8)-keV proton, 100us.

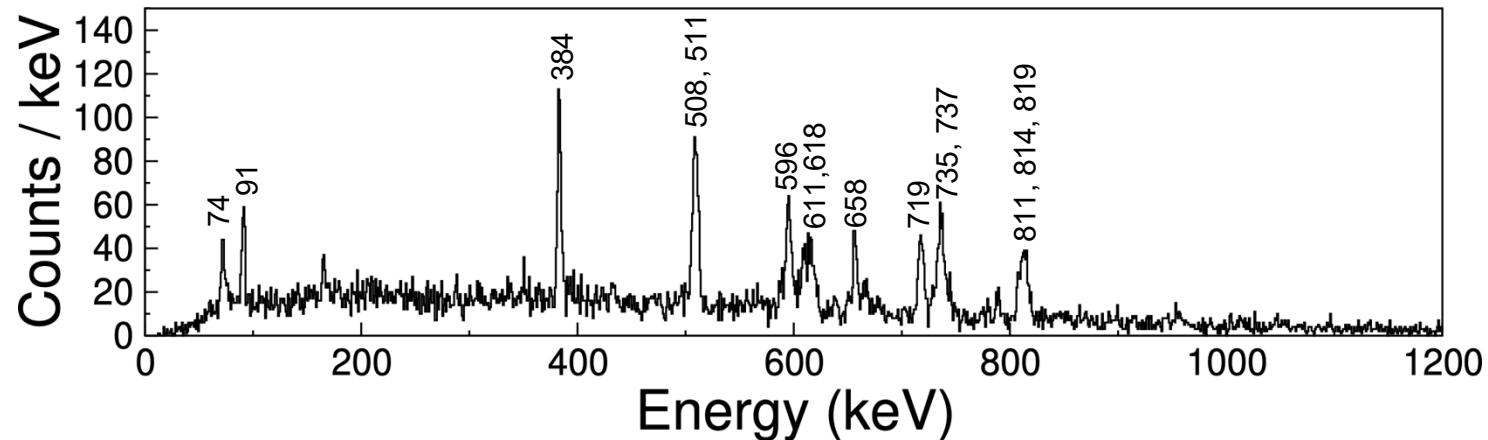

This experiment

$^{58}\text{Ni}(^{58}\text{Ni}, p2n)^{113}\text{Cs}$ $E_{\text{beam}} = 230 \text{ MeV}$
target thickness = 700 ug/cm^2 $I_{\text{beam}} \approx 3 \text{ pA}$

Total data
represented in figure :
~221 GB

Recoil-proton tagged: [930, 1100]-keV proton, 100us.

Extra: Δt between DSSD and Punch through

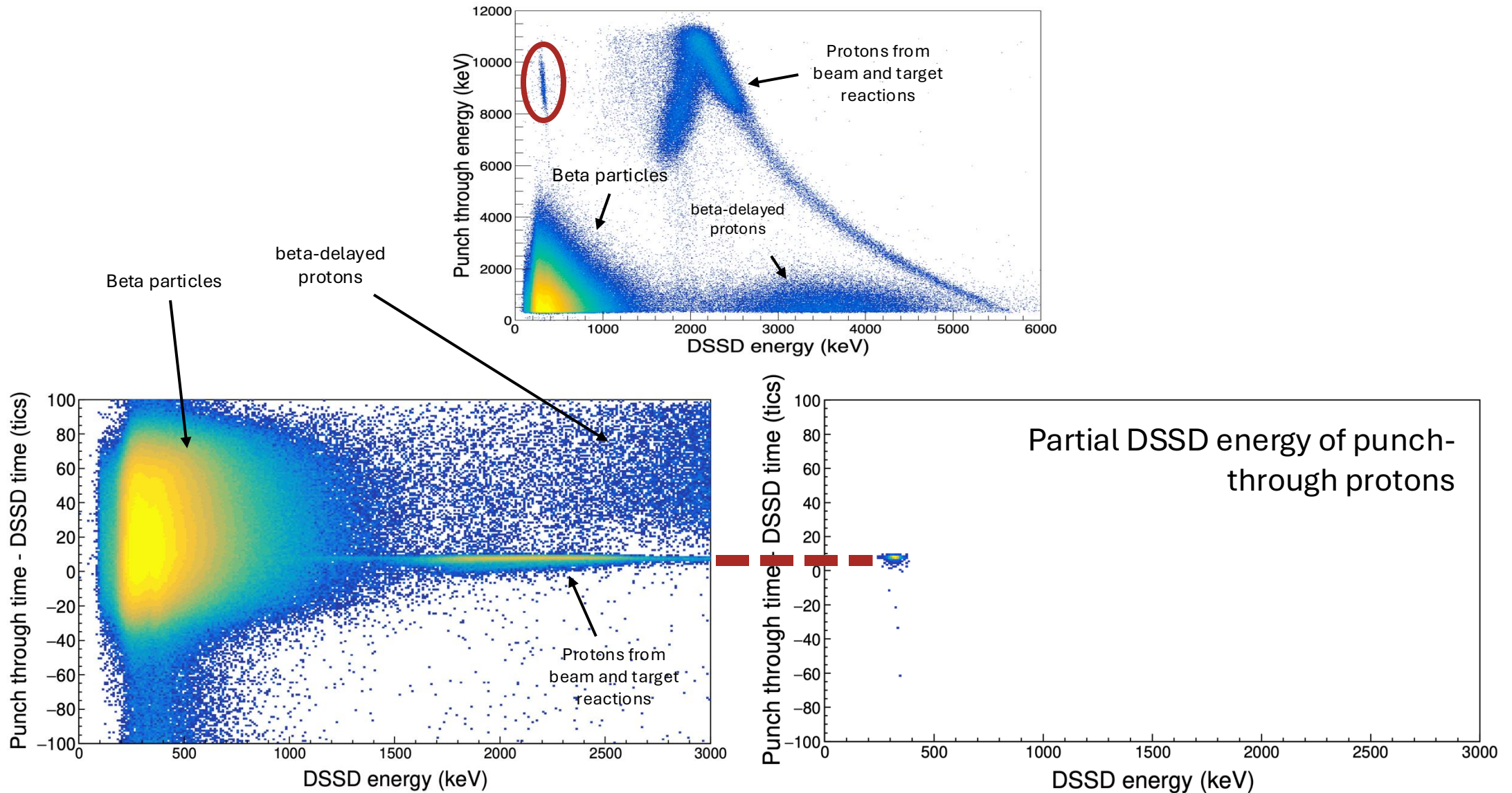

Extra: Protons hitting dead strips of the DSSD

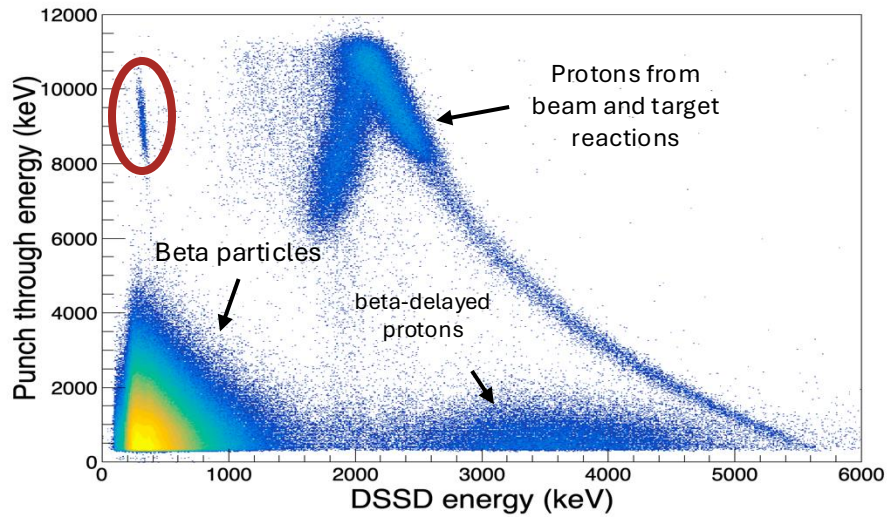

- Dead strip hit on DSSD
- Induced charge partially collected in neighbouring strips

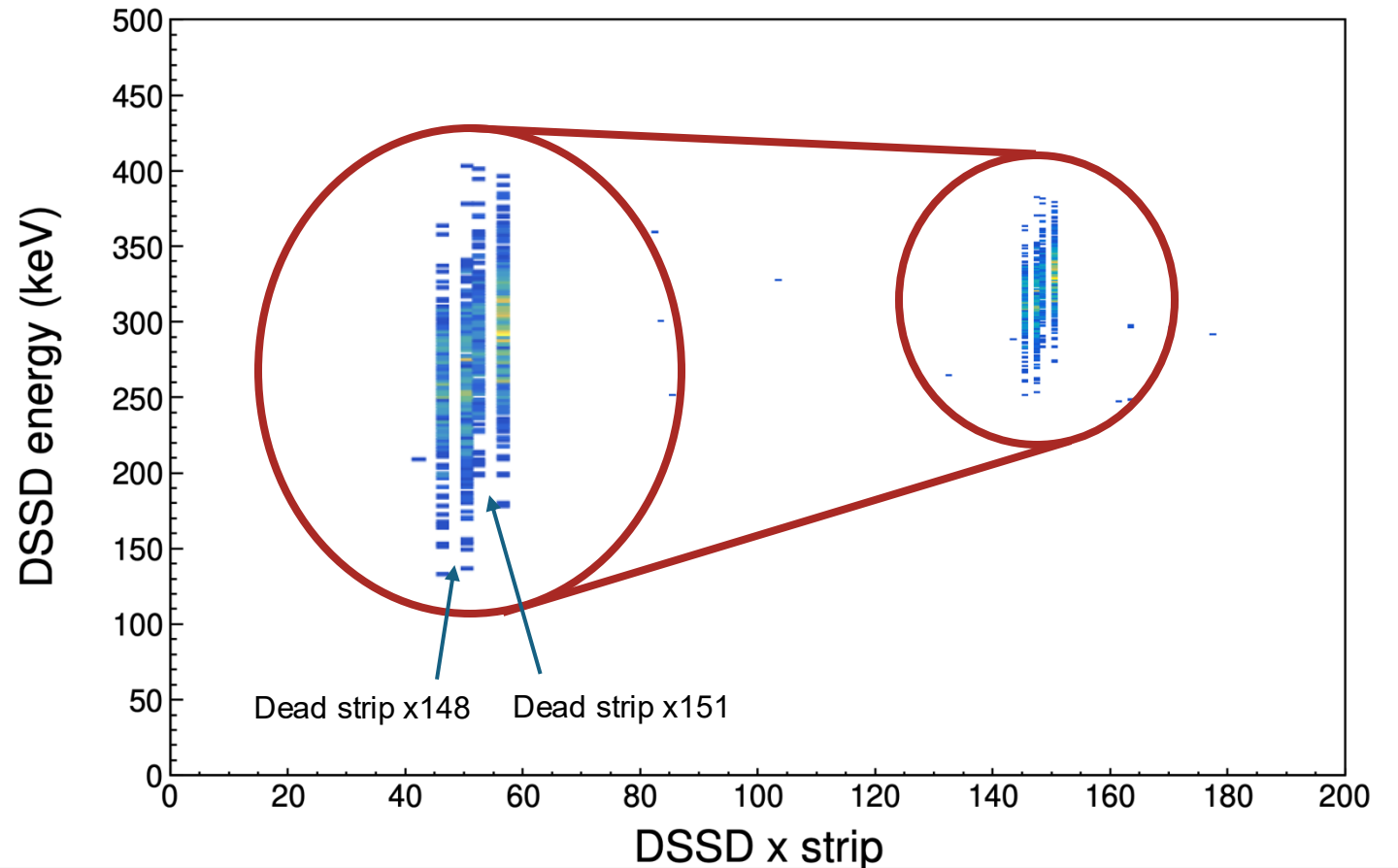

Extra: Relative efficiency of jurogam

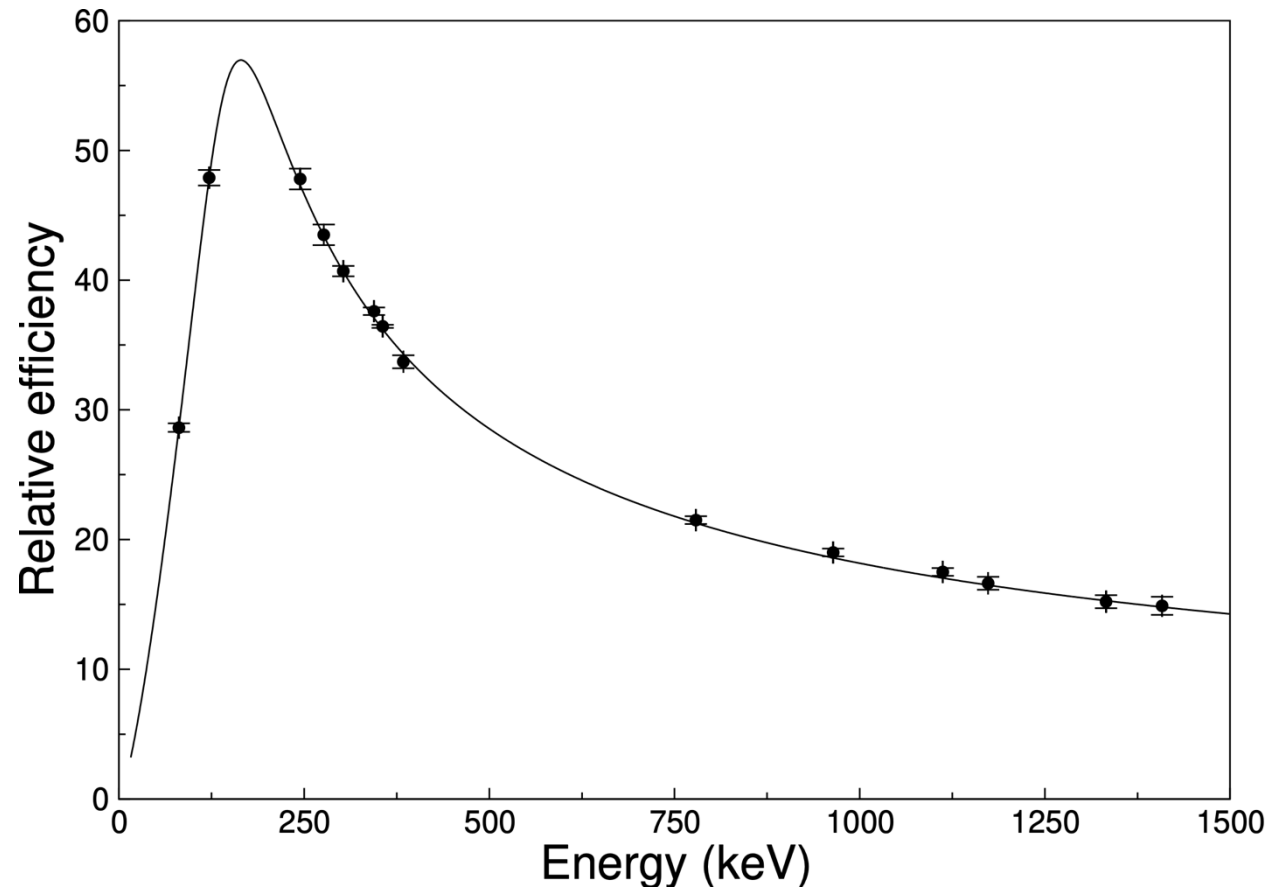

Extra: MARA mass slits

