

PoPLAR PMQs and Measurements

Hywel Owen, Thomas Smith, Ben Shepherd, Neil Thompson
STFC Daresbury Laboratory
Accelerator Science and Technology Centre

7th April 2025

LhARA 7th Collaboration Meeting, <https://indico.stfc.ac.uk/event/1438/>

Beamline Layout

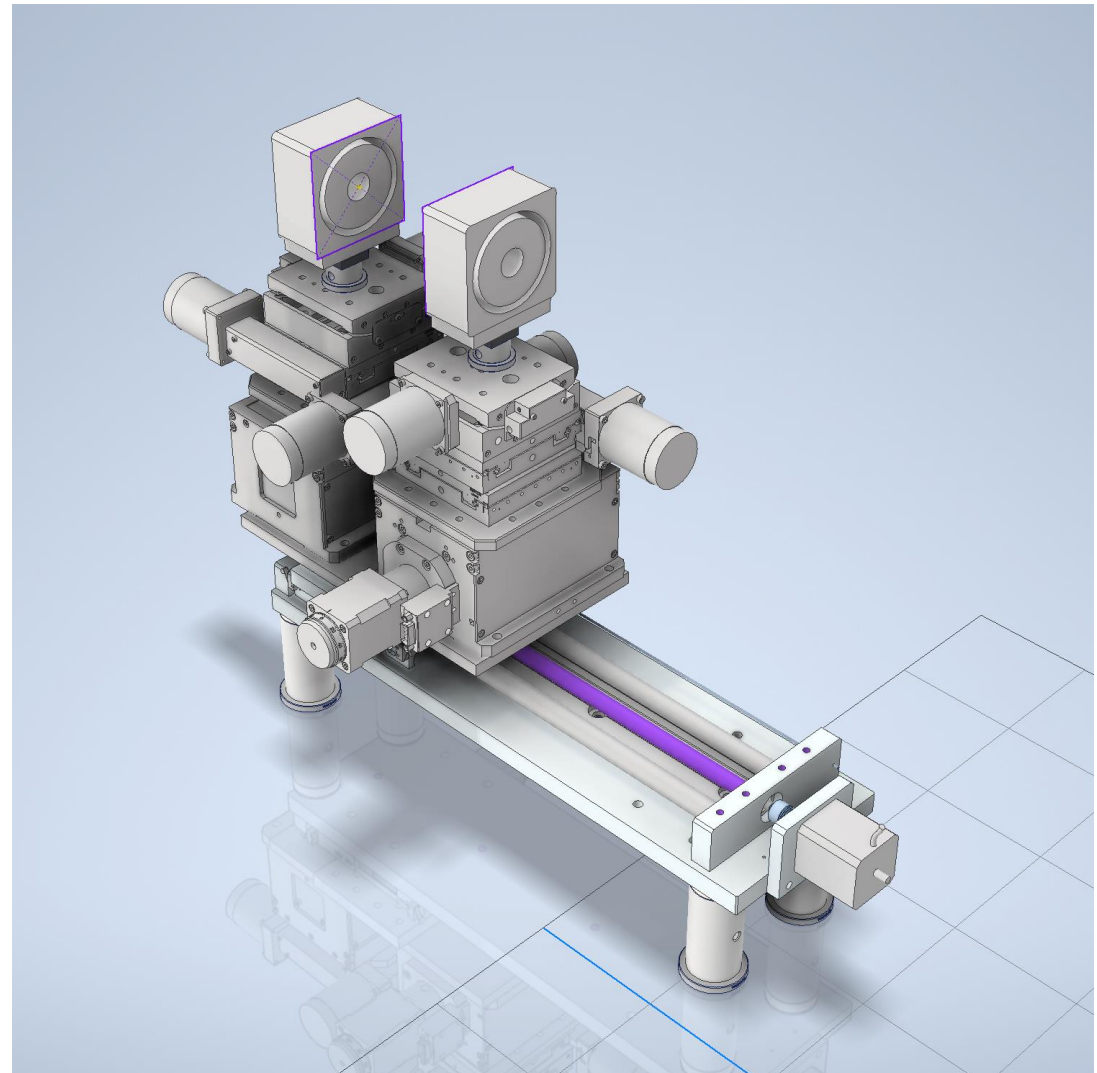
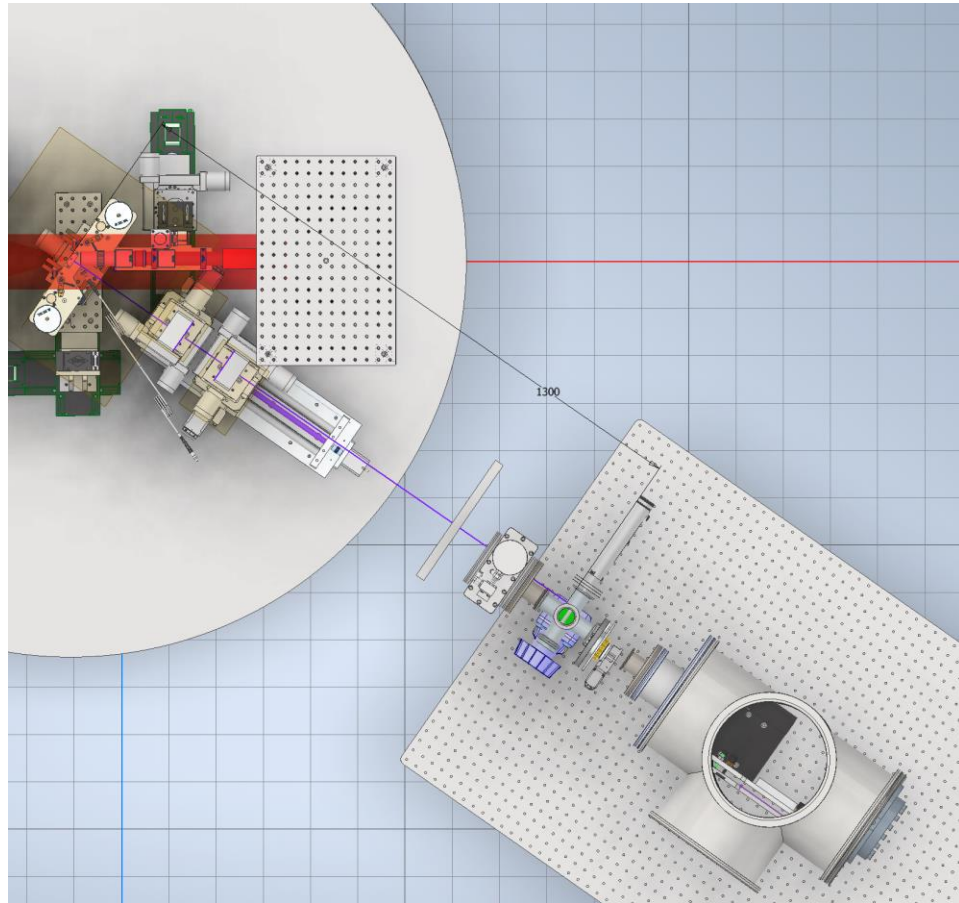

Specification

- Pure PPM design
- Four mounting faces to enable F/D in both orientations
- Serial number and reference marks to reference against field maps
- Ni-coated for vacuum compatibility

Table 1: Main Parameters for PoPLAR quadrupoles.

Parameter	Value
Number off	6
Internal clear aperture	20 mm (diameter)
Good field region	18 mm (diameter)
Integrated gradient	3 T
Maximum physical length	20 mm
Implied peak gradient	≈ 150 T/m

MagnetSales models

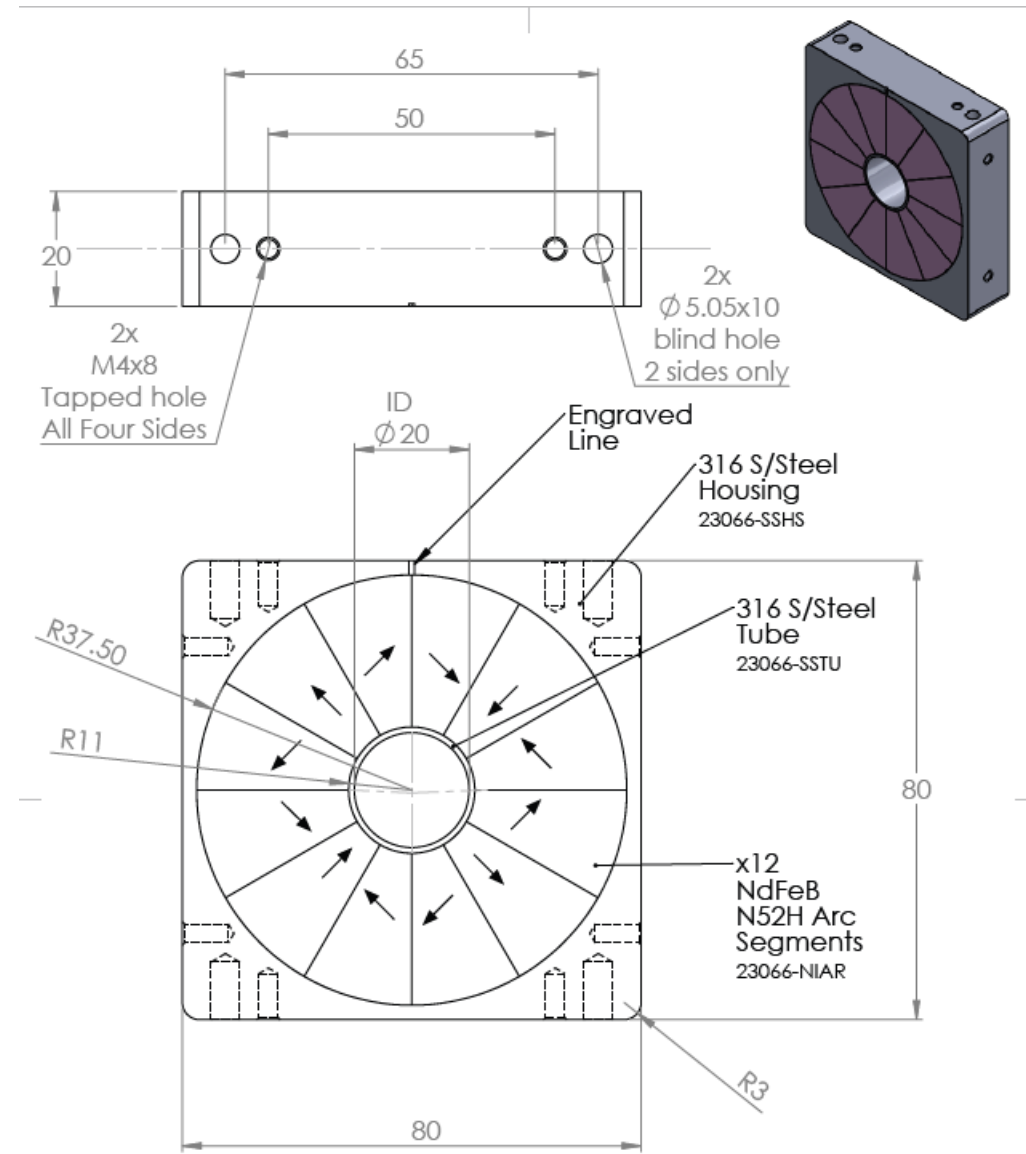
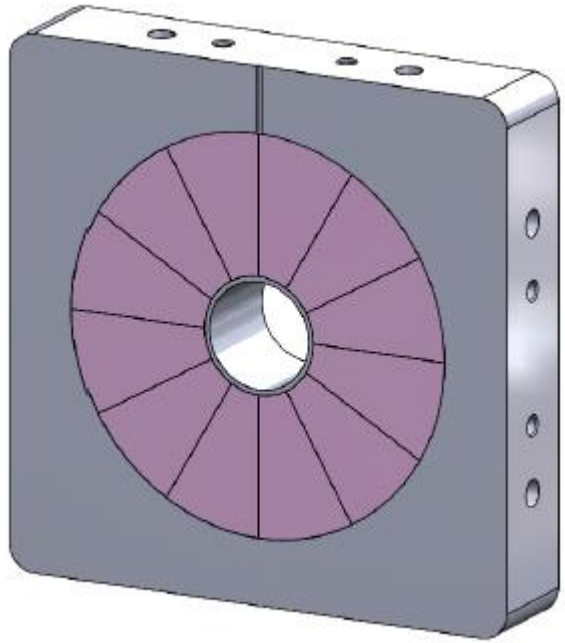

Measurement
(same scale)



ONE QUAD

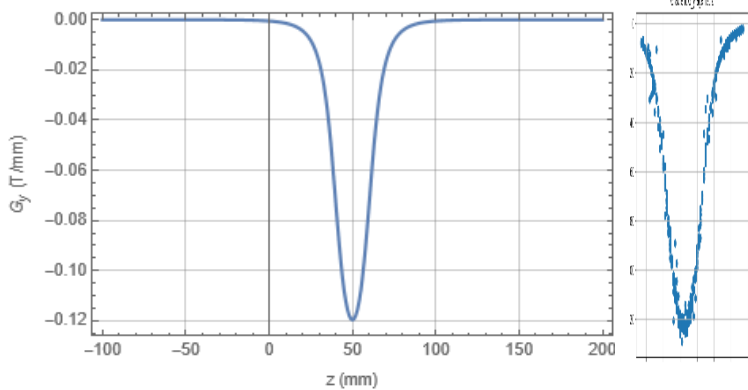
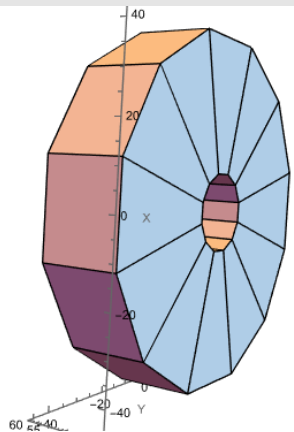

Integrated Gradient **$G_1 = -3.12883 \text{ T}$**

TWO QUADS, 5mm GAP

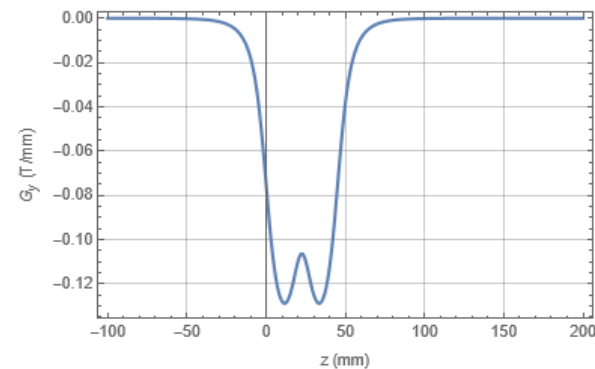
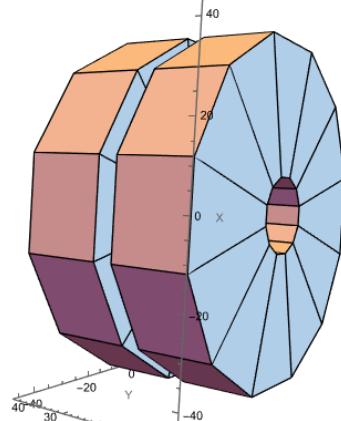

Integrated Gradient = $-6.26385 \text{ T} = \mathbf{G_1 * 2.002}$

TWO QUADS, NO GAP

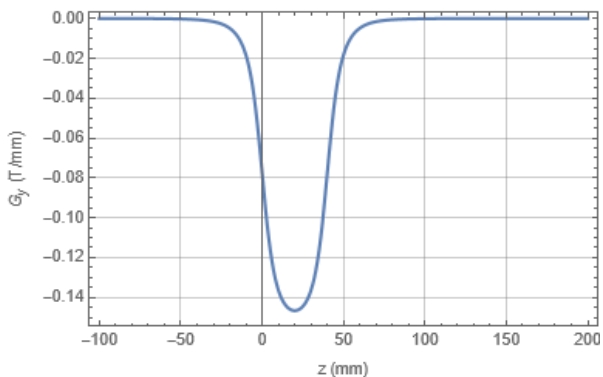
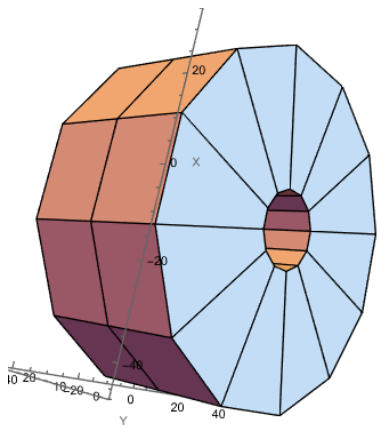

Integrated Gradient = $-6.25824 \text{ T} = \mathbf{G_1 * 2.0002}$

TWO QUADS, 20mm GAP

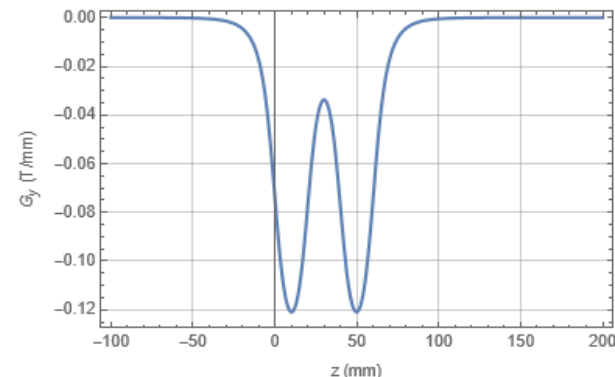
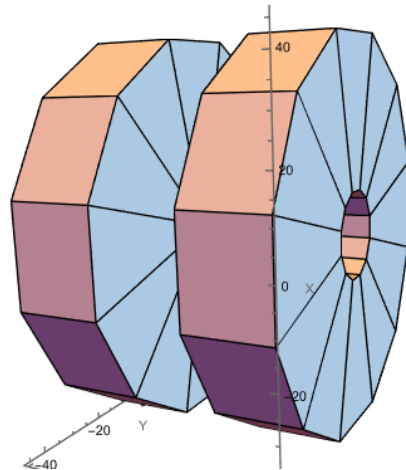

Integrated Gradient = $-6.25036 \text{ T} = \mathbf{G_1 * 1.9997}$

Issue: Magnetic Forces

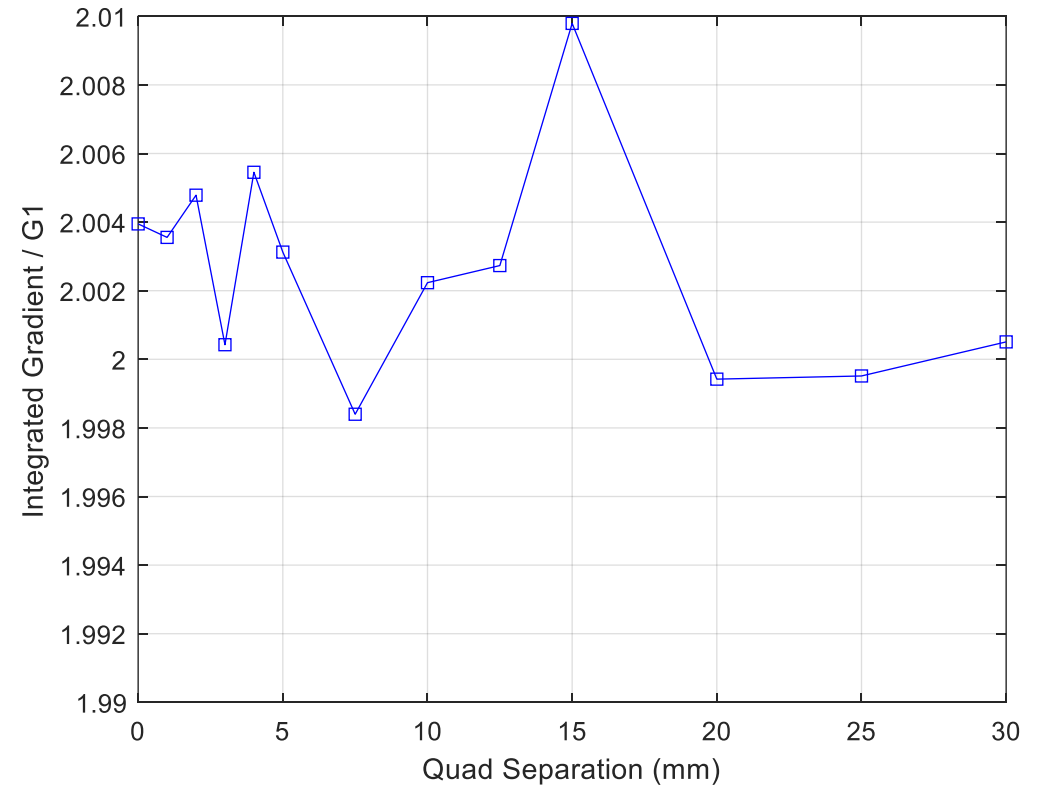
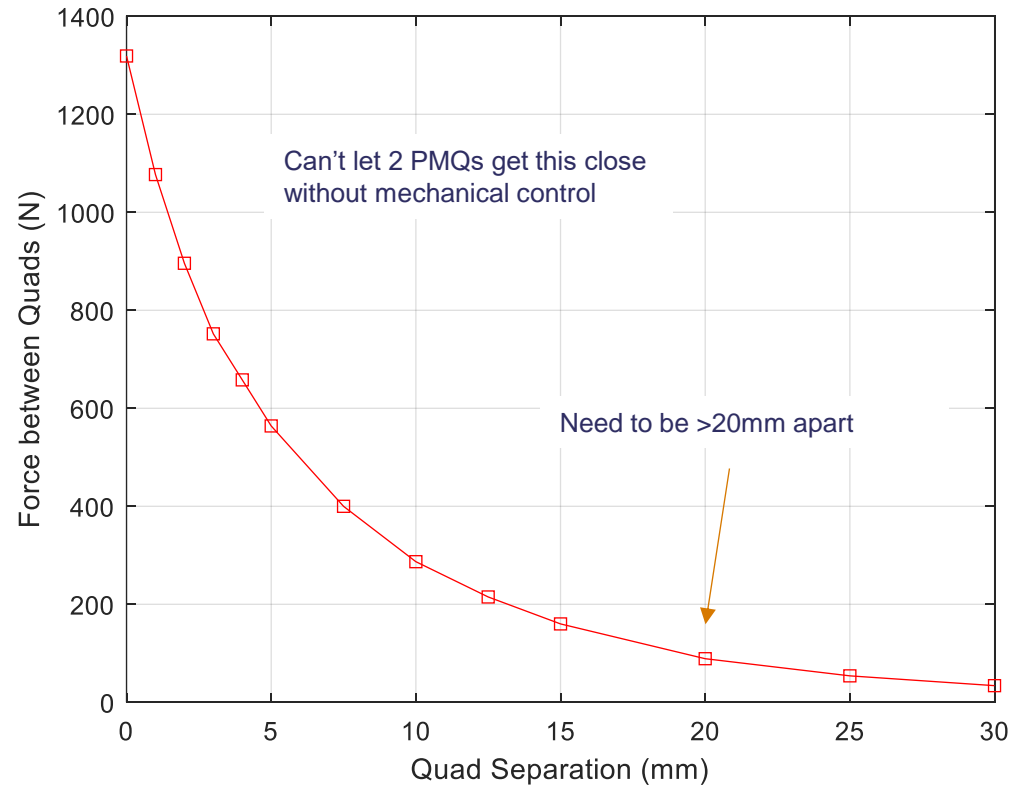

Bench measurements

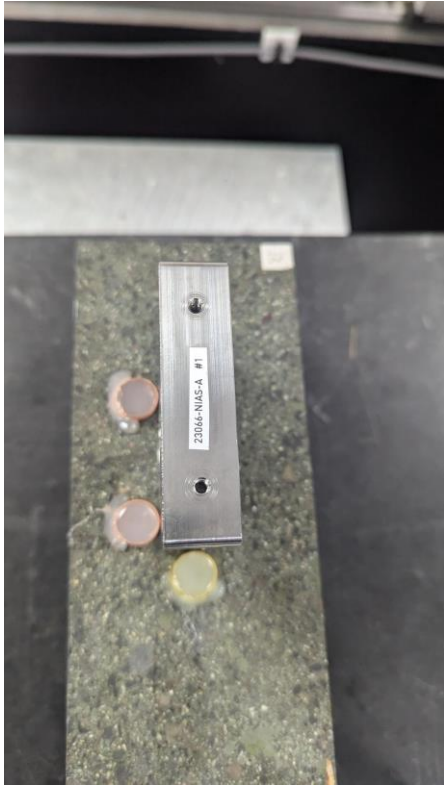

(spot the difference!)

- Hall probe has a finite size and length
- Can only scan +/-4mm in x/y
- Can't map full z field fall-off in one go
- Measured all 6 quads from both sides

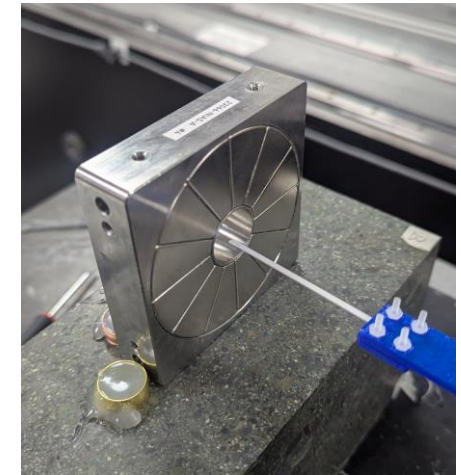
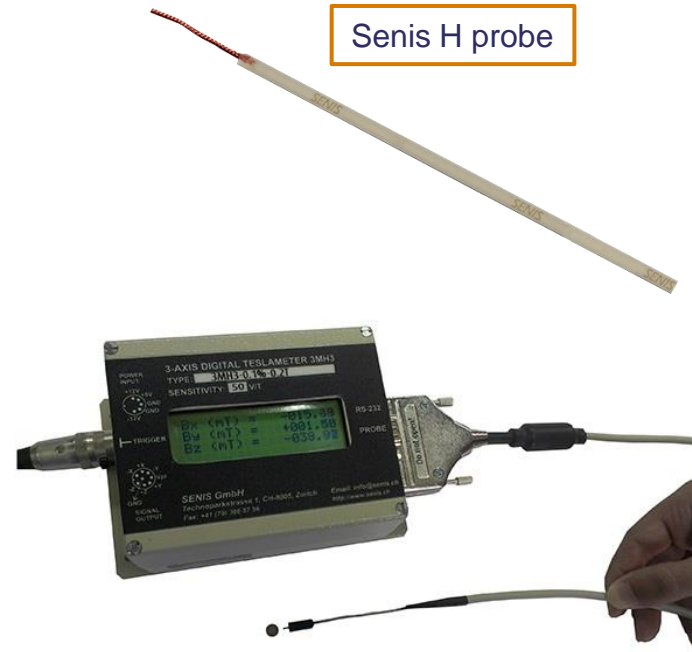

Probe toolpath

- Sequential points over x,y,z
- 1st-order interpolation from points (could do 2nd-order but haven't yet)

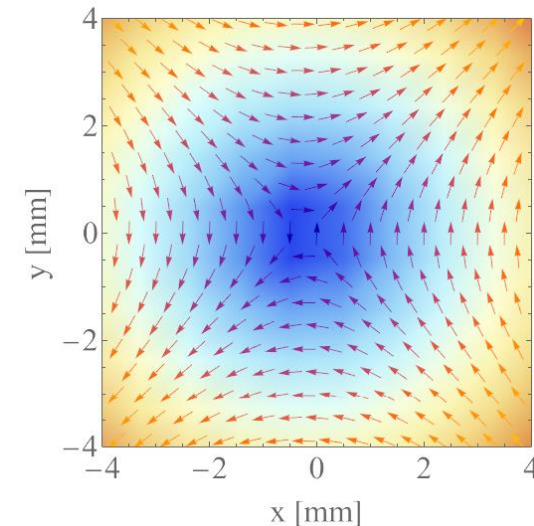
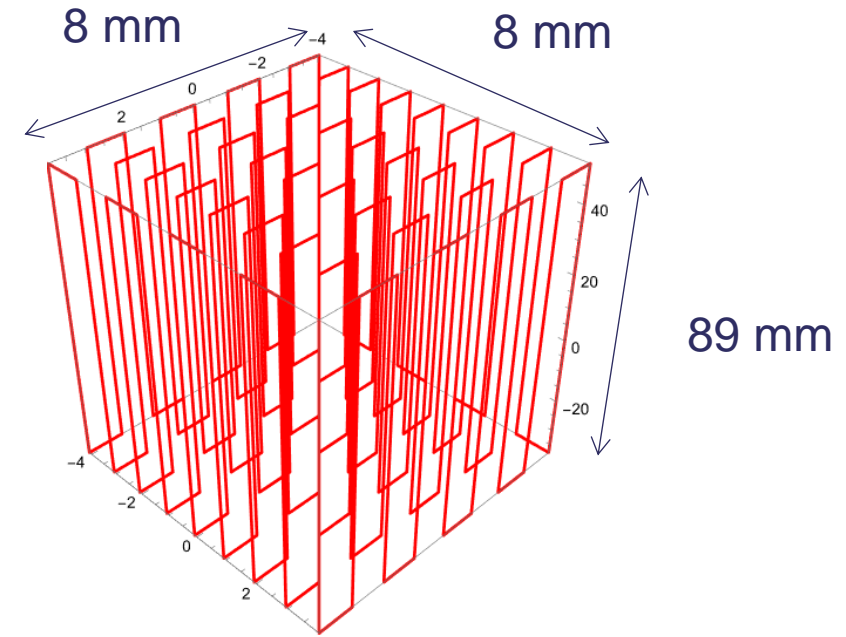
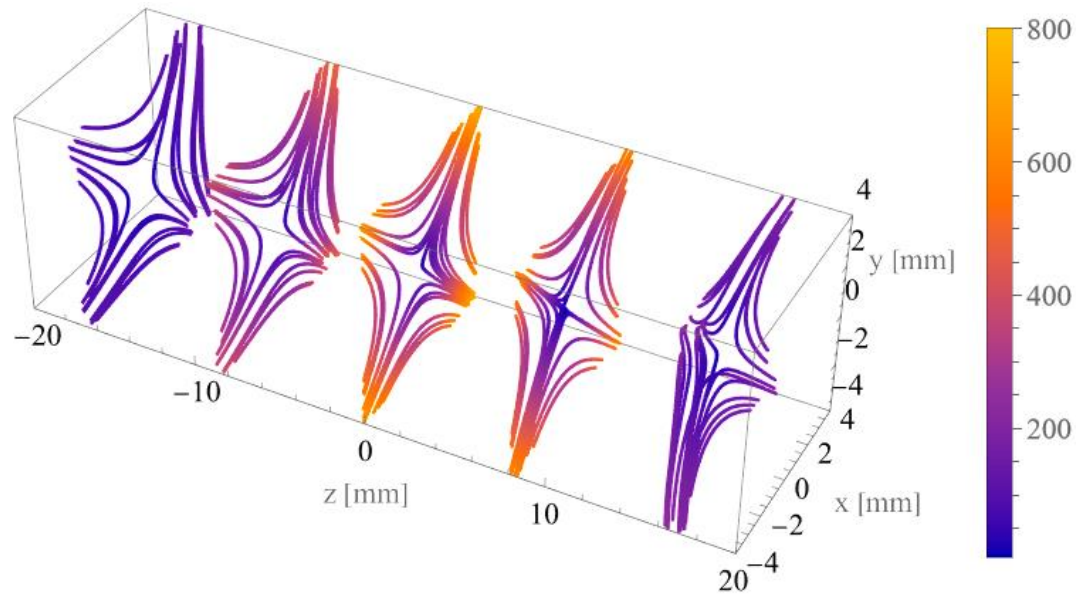

Matching the magnet positions

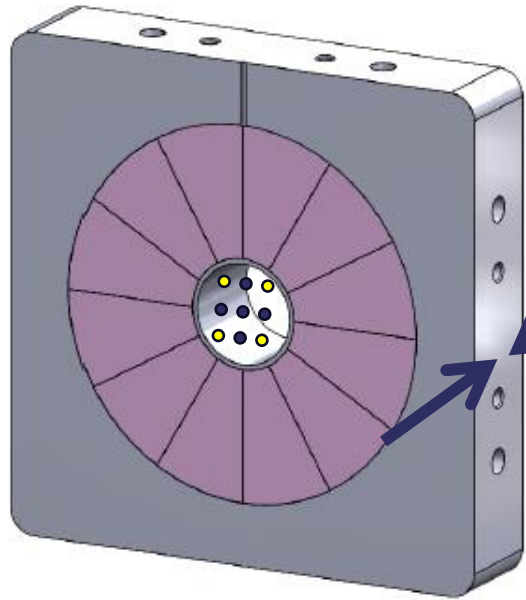

- z-field fitting
- x/y-field fitting

- Least-squares fit in z,x,y fields:
- Finds magnetic centre
- Matches 'Forward' and 'Backward' field maps to each other

Q1

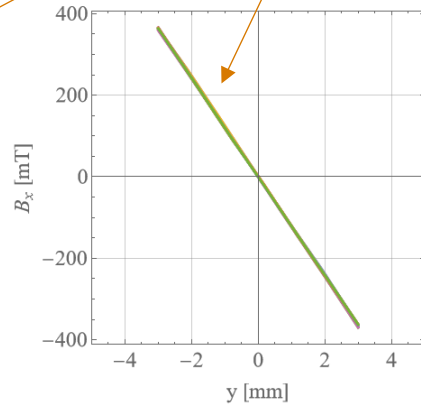
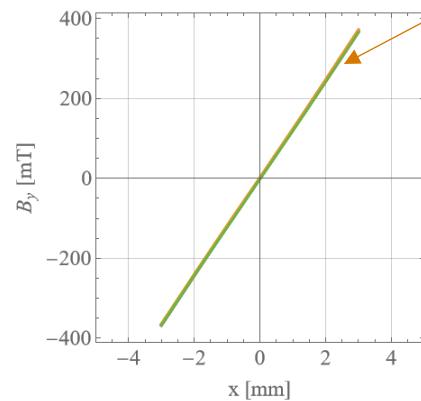

These are each 18 lines overlying each other.

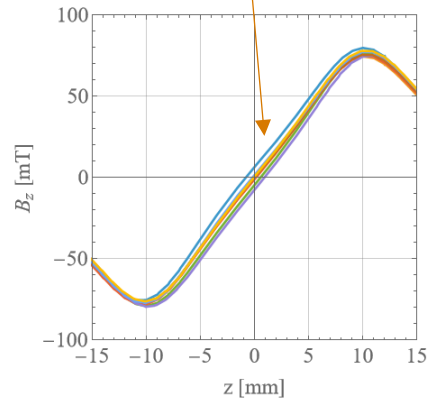

Some spread of 8 z fields; indicates some discretization error in measurements

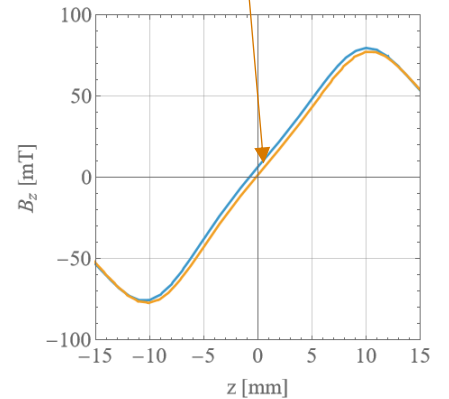

Comparing 'FWD' and 'BWD' for one offset location; indicates how well we can match the two field maps together.

Q1 to Q6

Q1

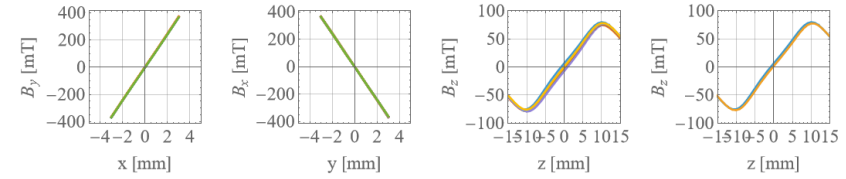

Q2

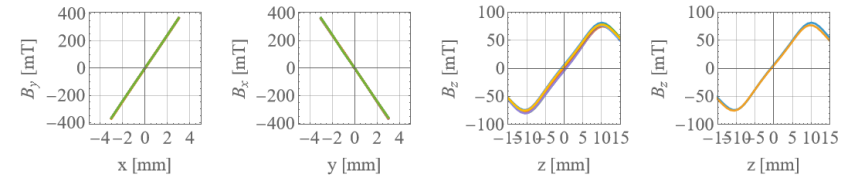

Q3

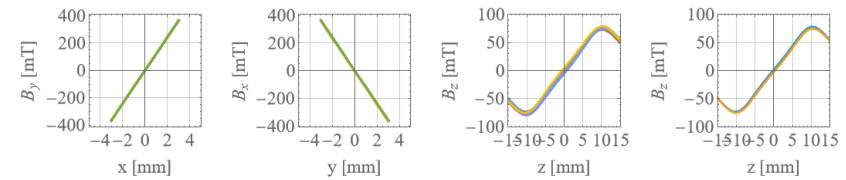

Q4

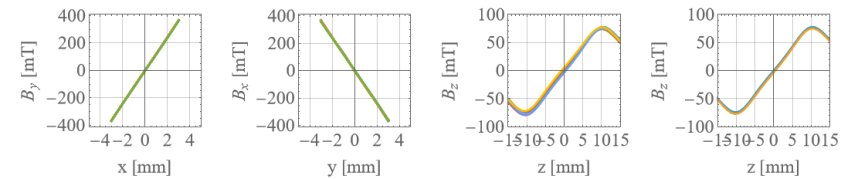

Q5

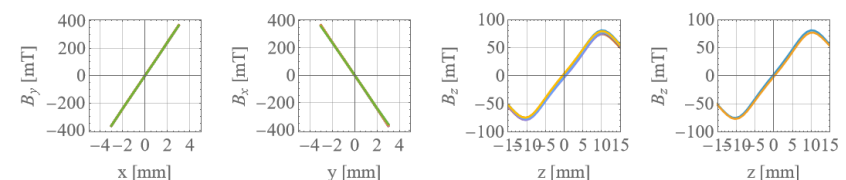

Q6

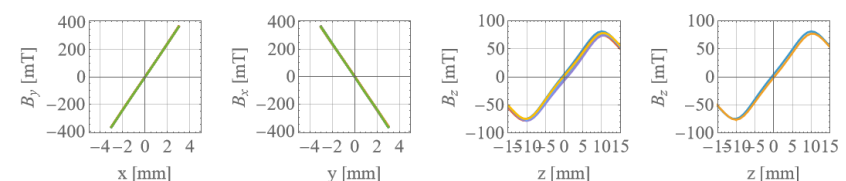

Longitudinal Gradient

- Can obtain gradient by differentiating the field map
- Do either for the (B_x, y) field or the (B_y, x) field
- Can clearly see where the probe 'can't go' on the 'Forward' and 'Backward' orientations
- Gradients all agree
- Can extract integrated gradient

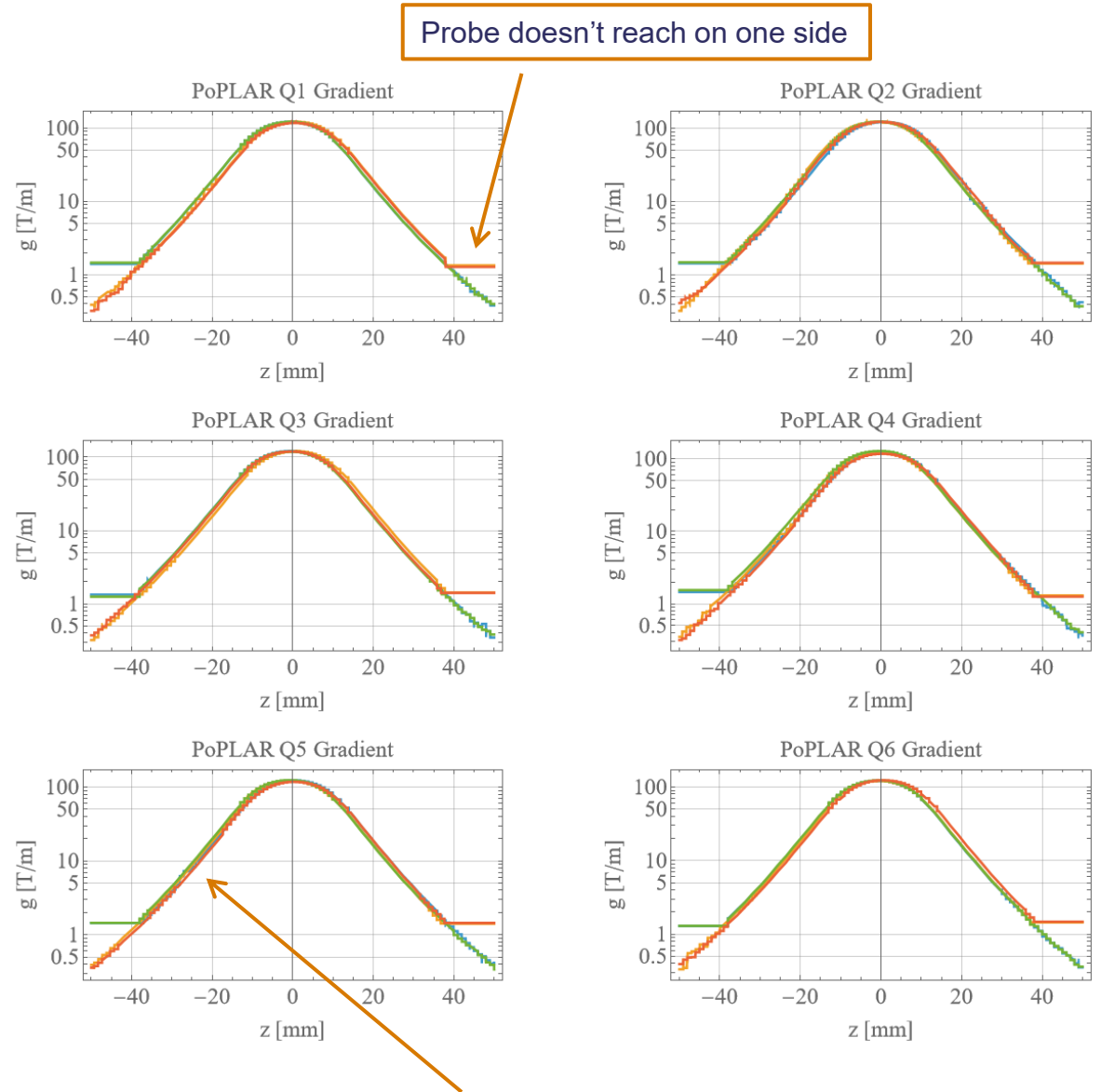

Gradient variation with x & y

- Limitation here is that measurements are on a 1mm grid spacing
- Linear interpolation gives numerical artefacts when differentiated (expected)
- **Underlying field map is fine!**
- Looks fine

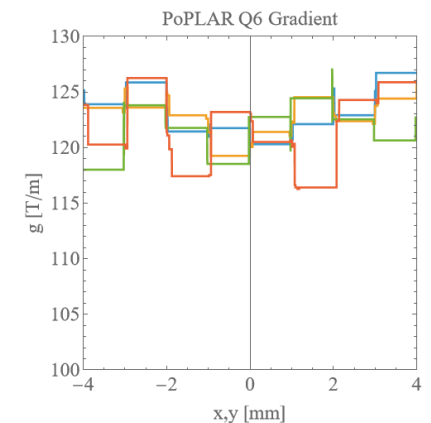
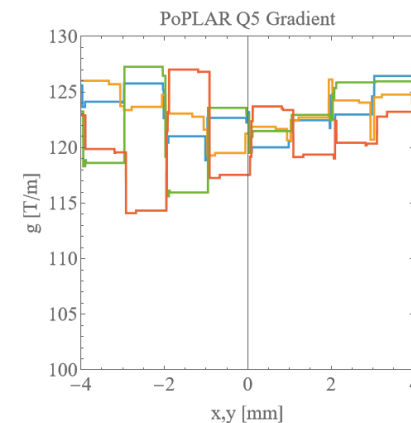
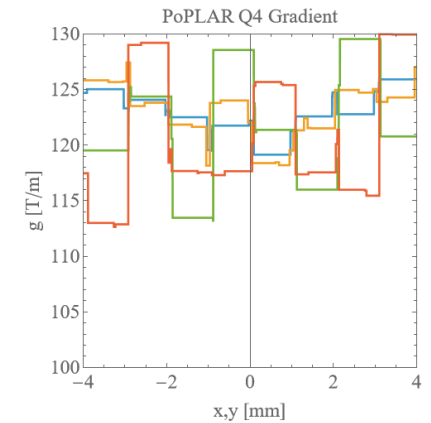
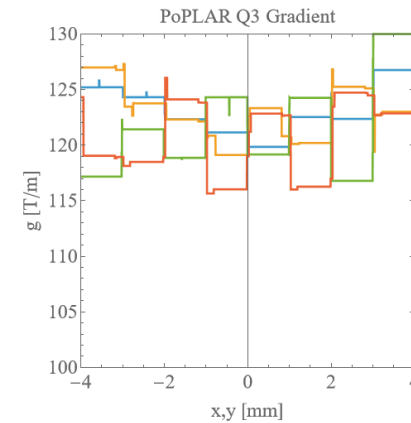
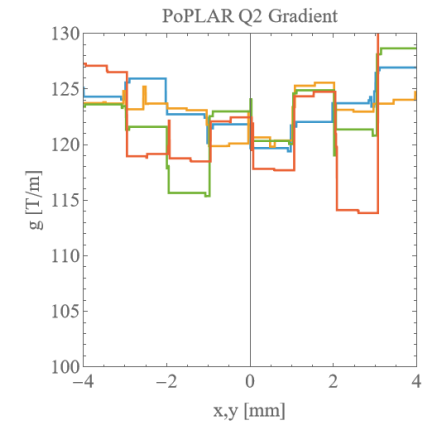
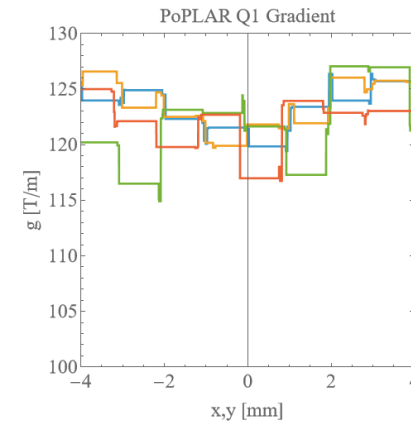

Summary of Measurements

- Variation and quality as expected for this type of quad/price:
- Achieves central gradient
- 5% variation in integrated gradient (but we know which is which)
- Can determine centre position to around 60um
- Roll error <0.5 deg

Serial Number	Int. Norm. Skew. *	Roll error (mRad)	Roll error (deg)
23066-NIAS-A #1	146	7.3	0.418
23066-NIAS-A #2	-79	-3.95	-0.226
23066-NIAS-A #3	-64	-3.2	-0.183
23066-NIAS-A #4	29	-1.45	0.083
23066-NIAS-A #5	13	-6.5	0.037
23066-NIAS-A #6	61	3.04	0.174

Comparison of survey and field map data (Forward only)	Q1	Q2	Q3	Q4	Q5	Q6
x Difference	13um	9um	10um	-5um	-4um	16um
y Difference	-68um	-30um	-34um	40um	49um	10um
z Difference	39um	100um	1um	8um	-65um	1um

Field Integrals Along Beam Axis (T) (from fieldmapping)	Q1	Q2	Q3	Q4	Q5	Q6						
Forward By	3.06	3.31	3.06	3.30	3.32	3.05						
Forward Bx	3.08	3.11	3.00	3.25	3.09	3.08						
Backward By	3.05	3.38	3.01	3.30	3.31	3.24						
Backward Bx	2.95	3.19	3.23	3.00	3.00	3.10						
Average	3.04	0.06	3.25	0.12	3.08	0.11	3.21	0.14	3.18	0.16	3.12	0.08

Recommendations

- Can't really rely on external surfaces to determine magnetic centre
- Proven difficult to get matched field map that includes all the fringe field (probe limitation)
- Field maps can be generated from measured data, but have interpolation limitation due to map size and range
- However, field maps confirm that the quads are as originally modelled
- Should probably use field maps generated from simulation if tracking is to be done.