

INTRODUCTION TO BEAM DYNAMICS (24/25)

Ian Bailey Lancaster University/Cockcroft Institute

ian.bailey@cockcroft.ac.uk

Introduction to beam dynamics

Syllabus (6 lectures)

Multipole fields

Equations of motion in dipoles and quadrupoles

Thin lens approximation

FODO cells

Hill's equation

Piecewise solutions

Courant-Snyder solutions

Tunes and resonances

Transverse emittance and Liouville's theorem

Dispersion

Chromaticity

Phase slip and momentum compaction factor

Synchrotron motion

Synchrotron radiation (damping and quantum excitation)

Introduction to beam dynamics

Today!

Syllabus (6 lectures)

Multipole fields

Equations of motion in dipoles and quadrupoles

Thin lens approximation

FODO cells

Hill's equation

Piecewise solutions

Courant-Snyder solutions

Tunes and resonances

Transverse emittance and Liouville's theorem

Dispersion

Chromaticity

Phase slip and momentum compaction factor

Synchrotron motion

Synchrotron radiation (damping and quantum excitation)

Additional learning material for this course

Course Material

CI Courses

<https://www.cockcroft.ac.uk/education/lectures>

CERN Accelerator Schools

<https://cas.web.cern.ch/>

Accelerator Science

Beam Dynamics

RF Systems

Magnets and Radiation Sources

Etc

Books (mostly available online)

Appleby et al, "The Science and Technology of Particle Accelerators"

Wolski, "Beam dynamics in high energy particle accelerators"

Lee, "Accelerator physics"

Wiedemann, "Particle accelerator physics"

Chao and Tigner, "The handbook"

Wille, "The physics of particle accelerators"

Forest, "Beam dynamics"

Wangler, "RF linear accelerators"

And many more....

PART ONE - INTRODUCTION

What is beam dynamics?

Particle accelerators are arrays of magnets and accelerating structures through which charged particles move in a predictable fashion, such that the particles can be thought of as forming a beam.

In the absence of the external forces provided by a particle accelerator, a bunch of charged particles will diverge.

Beam dynamics is the study of the motion of these particles :
Individually
Collectively

Beam dynamics allows us to design, optimise, upgrade, and operate accelerators.

Essentially, we need to solve the (relativistic) Lorentz force equation for each particle in a bunch of particles travelling through electromagnetic fields.

The standard approach to this problem and the standard terminology have been developed for common 'circular' accelerators such as synchrotrons. This is where we'll start.

Example - DIAMOND light source (an electron synchrotron)



Example - The LHC (a proton synchrotron)



Example - LHC parameters



Parameter	Design	2012	2016	2017
beam energy [TeV]	7	4	6.5	6.5
bunch spacing [ns]	25	50	25	25
β^* CMS/ATLAS [cm]	55	60	40	40 (33)
crossing angle [μ rad]	285	290	370 / 280	300
bunch population N [10^{11} ppb]	1.15	1.65	1.1	1.2
normalized emittance ε [μ m]	3.75	2.5	2.2	2.2
number of bunches per ring k	2808	1374	2220	2556
peak luminosity L [10^{34} cm ⁻² s ⁻¹]	1	0.75	1.4	1.7
peak average event pile-up μ	~ 20	~ 35	~ 50	~ 55
peak stored energy [MJ]	360	145	270	320

Example - LHC parameters



HL-LHC TECHNICAL EQUIPMENT:



Parameter	Design	2012	2016	2017
beam energy [TeV]	7	4	6.5	6.5
bunch spacing [ns]	25	50	25	25
β^* CMS/ATLAS [cm]	55	60	40	40 (33)
crossing angle [μ rad]	285	290	370 / 280	300
bunch population N [10^{11} ppb]	1.15	1.65	1.1	1.2
normalized emittance ϵ [μ m]	3.75	2.5	2.2	2.2
number of bunches per ring k	2808	1374	2220	2556
peak luminosity L [10^{34} cm ⁻² s ⁻¹]	1	0.75	1.4	1.7
peak average event pile-up μ	~ 20	~ 35	~ 50	~ 55
peak stored energy [MJ]	360	145	270	320

Energy of each particle

Example - LHC parameters

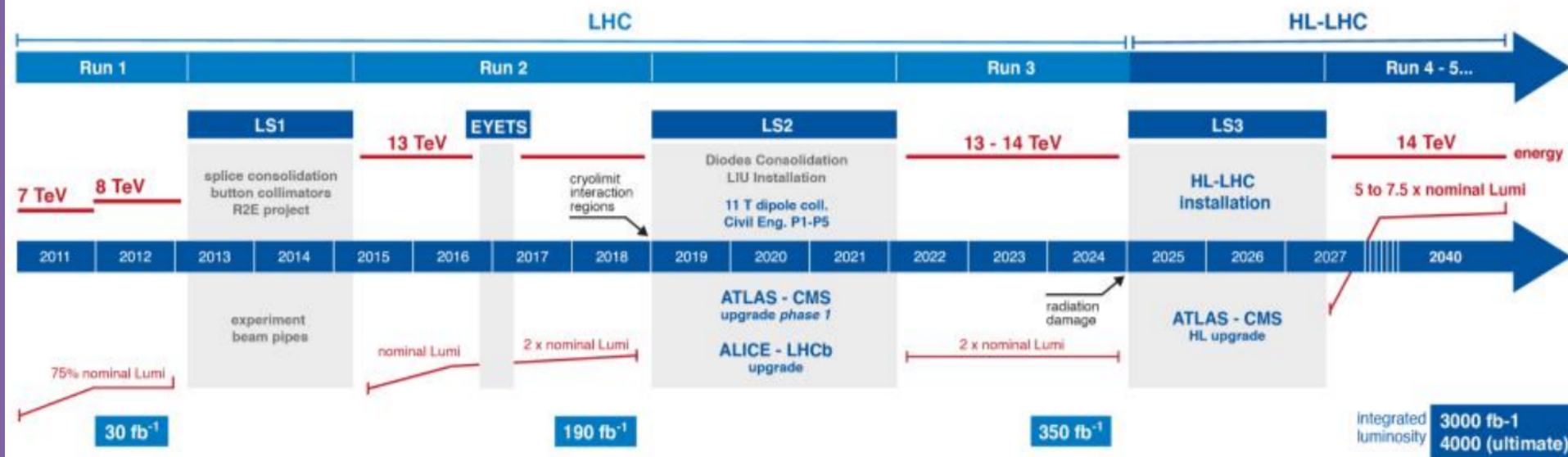

HL-LHC TECHNICAL EQUIPMENT:



Parameter	Design	2012	2016	2017
beam energy [TeV]	7	4	6.5	6.5
bunch spacing [ns]	25	50	25	25
β^* CMS/ATLAS [cm]	55	60	40	40 (33)
crossing angle [μ rad]	285	290	370 / 280	300
bunch population N [10^{11} ppb]	1.15	1.65	1.1	1.2
normalized emittance ε [μ m]	3.75	2.5	2.2	2.2
number of bunches per ring k	2808	1374	2220	2556
peak luminosity L [10^{34} cm $^{-2}$ s $^{-1}$]	1	0.75	1.4	1.7
peak average event pile-up μ	~ 20	~ 35	~ 50	~ 55
peak stored energy [MJ]	360	145	270	320

The closed orbit

There is a “closed design orbit” around the ring.

To maintain long lifetimes we need to focus the beam such that all particles oscillate around this design orbit with a small oscillation amplitude.

An example below shows the LHC beam (with size of a few microns) oscillating around the closed orbit ($\sim 27\text{km}$ long) with deviations of only a few millimetres.

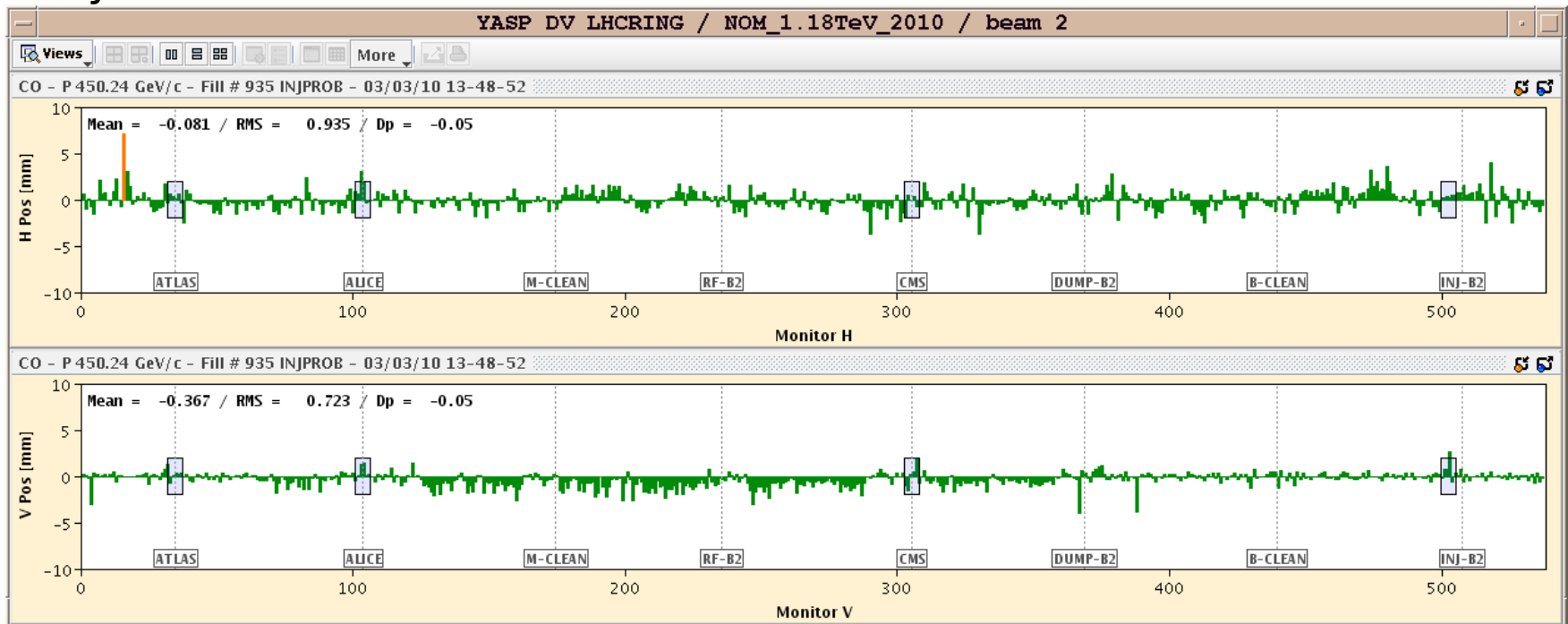

The role of beam dynamics

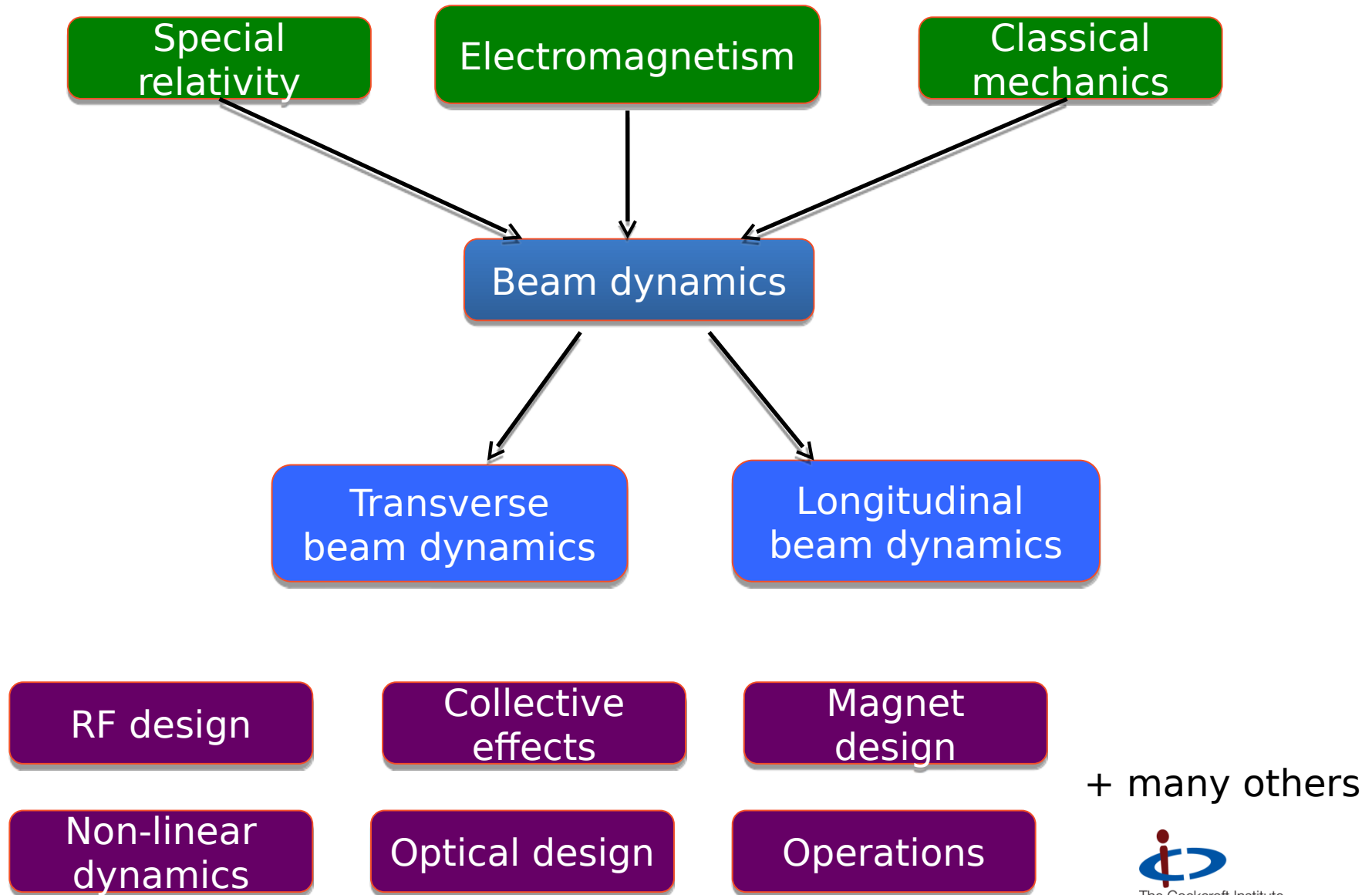

The role of beam dynamics

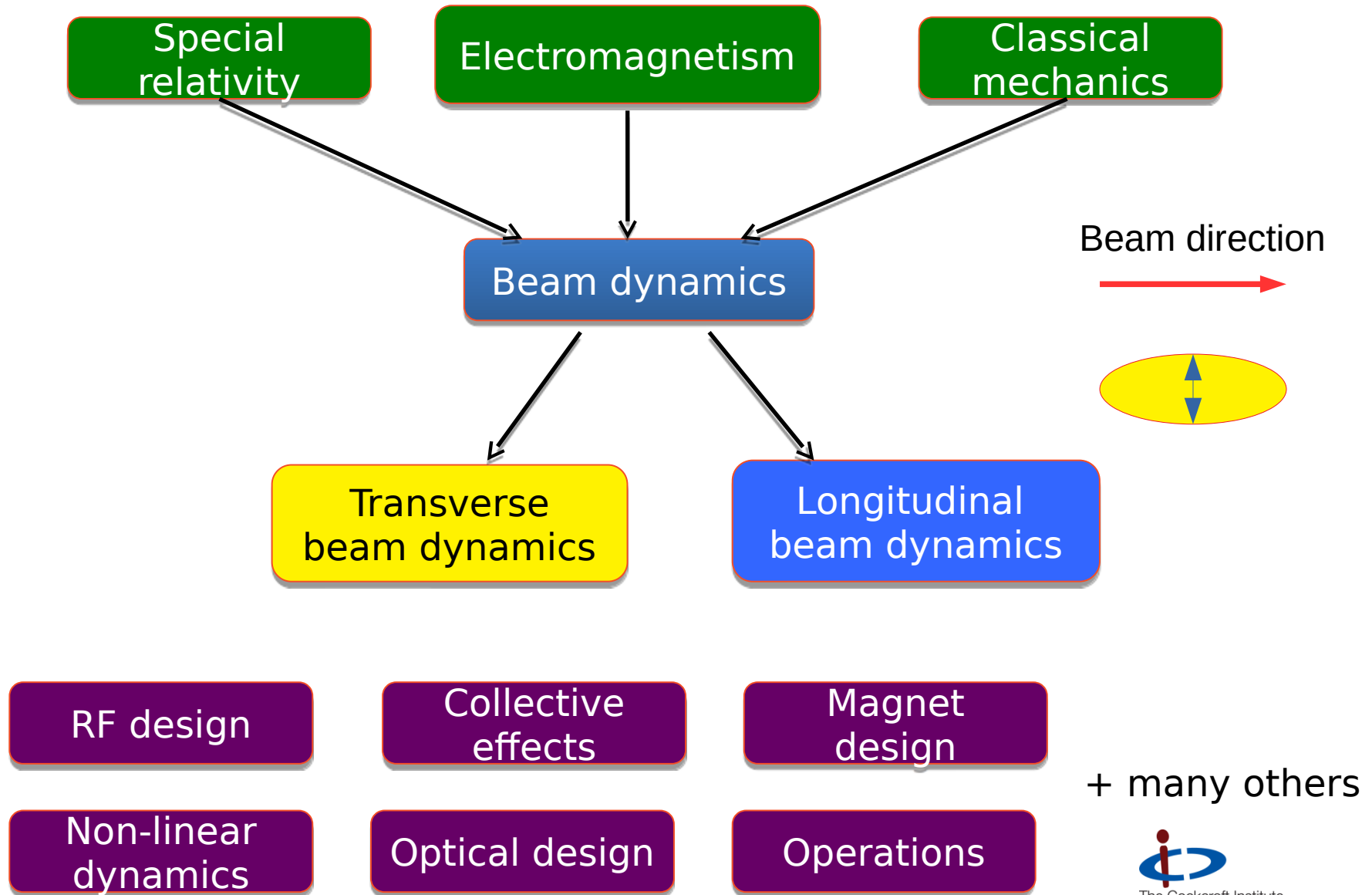

The role of beam dynamics

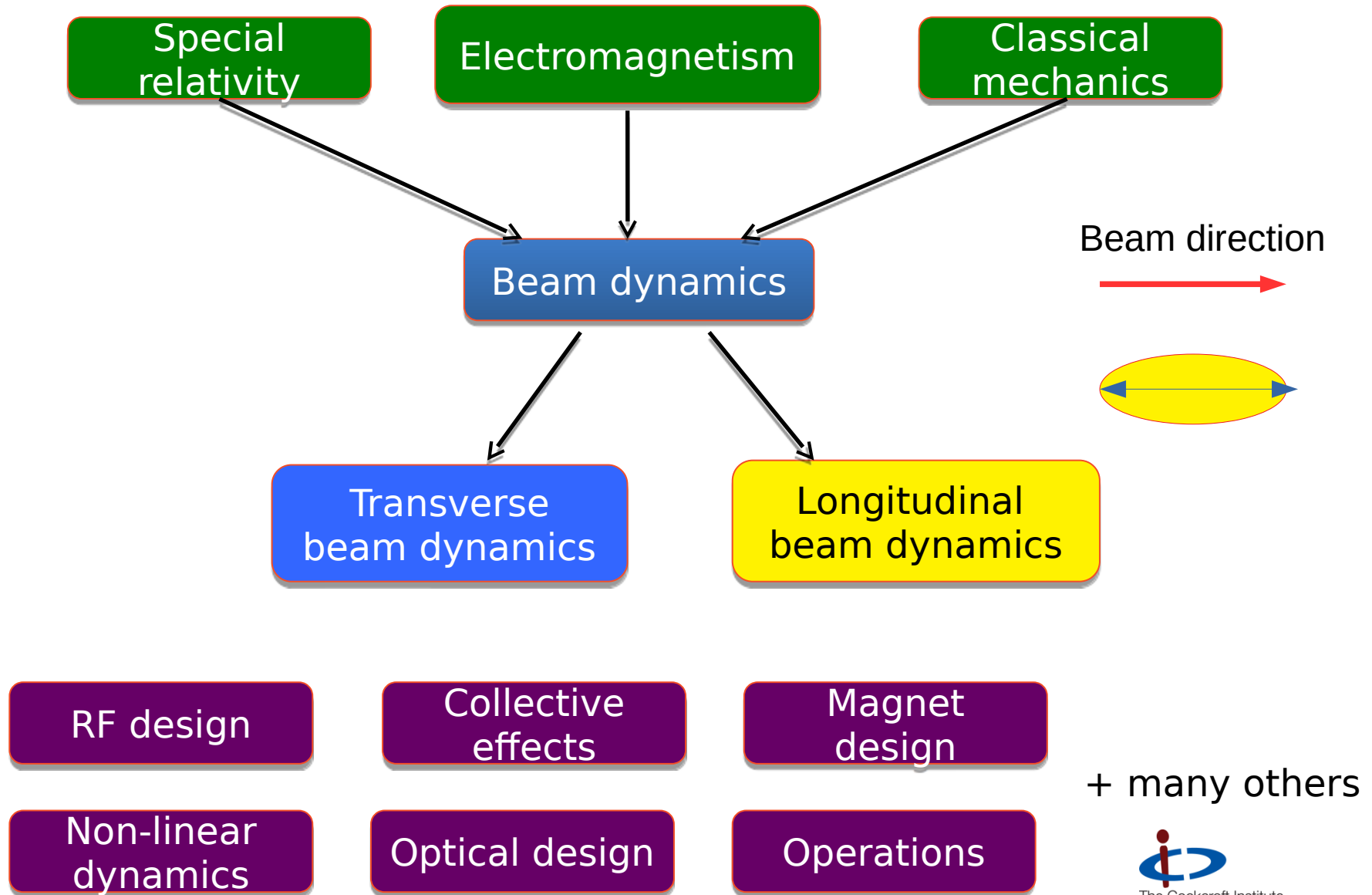

General simplifying assumptions (not always valid!)

- 1) The machine is periodic.
- 2) The particles spend a long time in the machine.
 - Their motion is **stable**.
- 3) The motion of an individual particle does not have the same periodicity as the machine, but the envelope of the motion (considering the motion of many particles or of one particle orbiting the machines many times) follows the machine periodicity.
- 4) The 'longitudinal' and 'transverse' motions of the particles happen on very different timescales, and so can be treated independently.

A simple harmonic oscillator

Let's consider another simple system which displays stable oscillations. Consider a mass, m , on a spring with spring constant k .

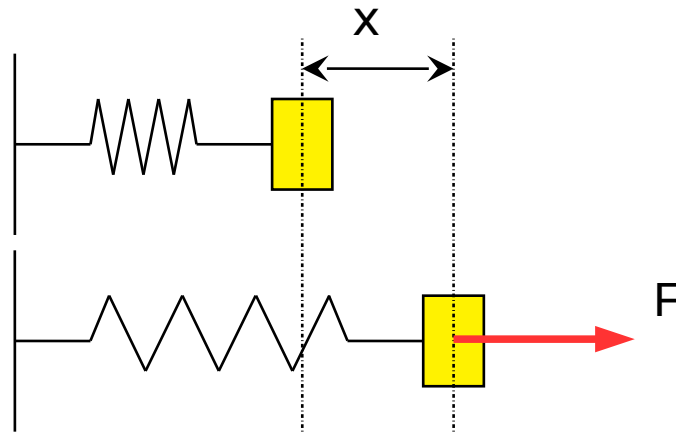

$$F = -kx$$

If the mass is displaced from equilibrium then the force on the mass from the spring returns the mass back towards the equilibrium point.

A simple harmonic oscillator

The force is given by

$$F = -kx$$

When we use Newton's law we get the equation of motion

$$m \frac{d\dot{x}}{dt} = -kx \quad \text{or equivalently} \quad \frac{d^2x}{dt^2} = -\frac{k}{m}x$$

This differential equation has an oscillatory solution (with two constants)

$$x(t) = A \sin(\omega t + \phi_0) \quad \omega = \sqrt{\frac{k}{m}}$$

Which we can also write as

$$x(t) = A_1 \sin(\omega t) + A_2 \cos(\omega t)$$

A simple harmonic oscillator with the opposite force

Consider a 'negative' spring constant

$$F = |k|x$$

Which leads to the standard equation of motion

$$\frac{d^2x}{dt^2} = \frac{|k|}{m}x$$

Note the force is now pushing the particle to larger amplitude, and we can write the solution (again with two constants) as

$$\omega = \sqrt{\frac{|k|}{m}} \quad x(t) = A_1 \sinh(\omega t) + A_2 \cosh(\omega t)$$

The Lorentz force law

We need to know what force plays the role of the spring in our mass-spring analogy.

The force on a charged particle of charge q from an electric field \mathbf{E} and magnetic field \mathbf{B} is given by the Lorentz force law

$$\vec{F} = q(\vec{E} + \vec{x} \times \vec{B})$$

\mathbf{E} and \mathbf{B} themselves are vector fields which can be calculated from Maxwell's equations in the presence of sources and boundary conditions (see courses on magnet design and rf cavities).

Often the particle speed in an accelerator can be approximated by the speed of light.

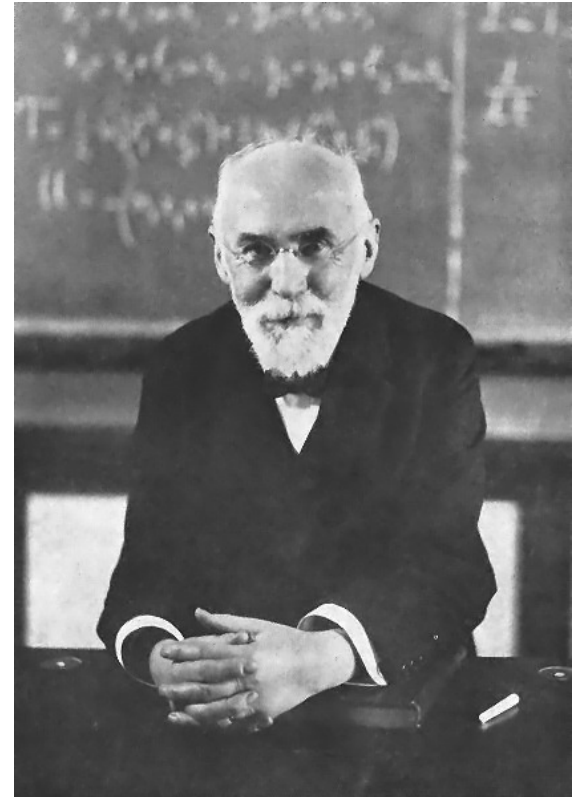

The Lorentz force law

We use electric fields to accelerate particles, and **generally** use magnetic fields to steer the particles. The force from a magnetic field benefits from the presence of the velocity in the Lorentz force law

$$\vec{F} = q(\vec{E} + \vec{x} \times \vec{B})$$

Consider a uniform magnetic field perpendicular to the particle velocity such that

$$B = 1T$$

The magnetic force on a particle of velocity $\approx c$ and charge q can be written as

$$F_B = q \times 3 \times 10^8 [m/s] \times 1 [Vs/m^2]$$

Which we could write in terms of an equivalent electric field

$$F_B = q \times 300 [MV/m]$$

NB - It is challenging to produce electric fields above 1 MV/m !

Transverse motion in an accelerator

We've seen that the simple harmonic oscillator equation, with different signs for the spring constant, can lead to oscillating and diverging solutions.

In the next lecture we will show that the basic equations of transverse motion for a particle in a simple accelerator take the form:

$$x''(s) + K(s).x(s) = 0$$

where s is the distance along the closed orbit. $K(s)$ can be thought of as a spring constant, and we expect that if it is positive we will get oscillating solutions, and if it is negative we will get diverging solutions, just as in our simple case of the simple harmonic oscillator.

We can think of an accelerator as being made up of piece-wise regions with different sizes and signs of the spring constant.

A circular design orbit

Let's start by assuming we apply a constant, uniform magnetic field to give circular motion.

The force on the particle is always at right-angles to the motion and given by

$$F_B = qvB$$

We equate this to the centripetal force

$$F = \frac{\gamma m_0 v^2}{\rho}$$

$$\Rightarrow qBv = \frac{\gamma m_0 v^2}{\rho}$$

$$\Rightarrow B\rho = \frac{p}{q}$$

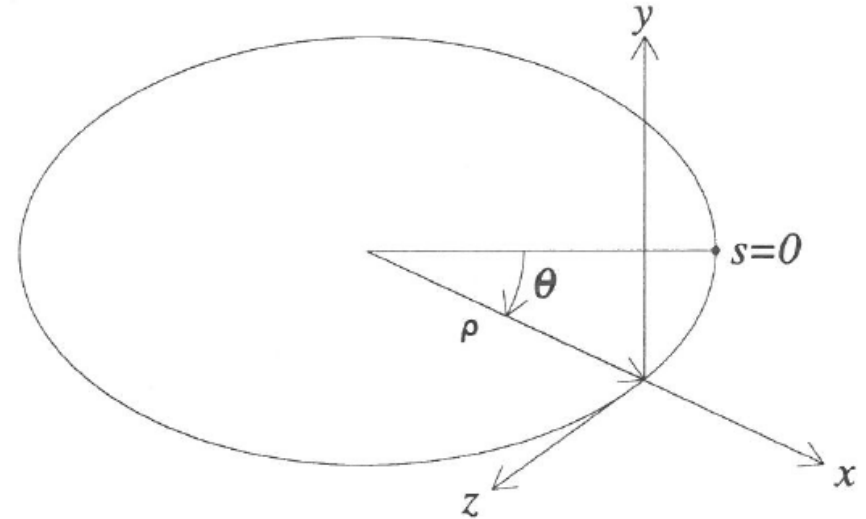

Here, γ is the Lorentz factor. Warning! Later we will use it to denote a different quantity!

A circular design orbit

Let's start by assuming we apply a constant, uniform magnetic field to give circular motion.

The force on the particle is always at right-angles to the motion and given by

$$F_B = qvB$$

We equate this to the centripetal force

$$F = \frac{\gamma m_0 v^2}{\rho}$$

$$\Rightarrow qBv = \frac{\gamma m_0 v^2}{\rho}$$

$$\Rightarrow B\rho = \frac{p}{q}$$

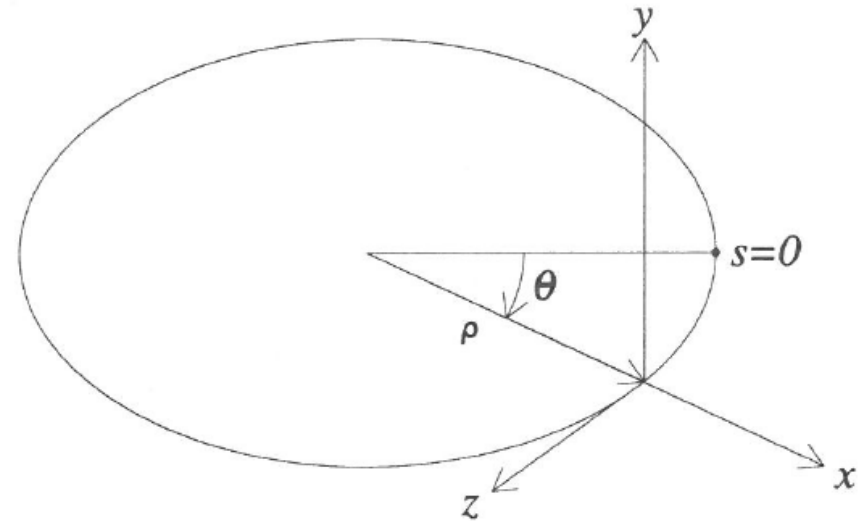

Here, γ is the Lorentz factor. Warning! Later we will use it to denote a different quantity!

A circular design orbit and beam rigidity

$$B\rho = \frac{p}{q}$$

A particle with relativistic momentum p and charge q in a guide field B will follow a circular path of radius ρ .

The product of the field and the radius is a function only of the particle momentum and charge.

p/q appears in the normalisation of many physical quantities in beam dynamics.

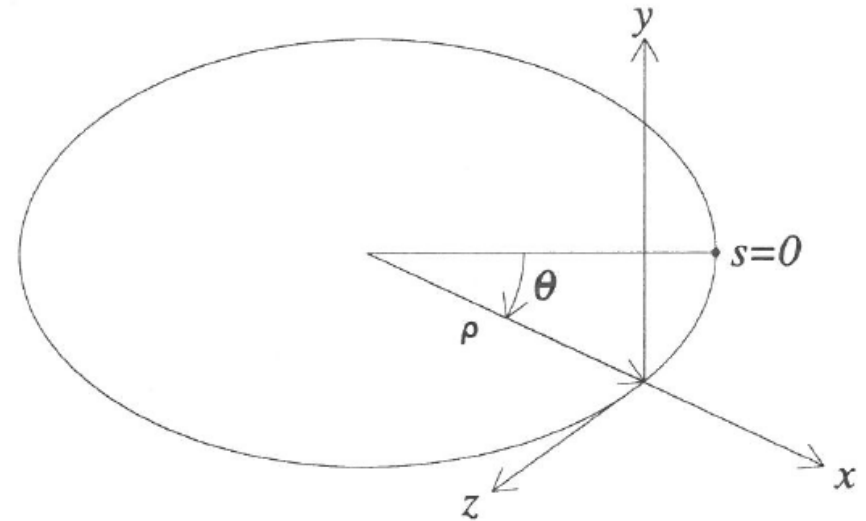

The quantity $B\rho$, called the beam rigidity, is often used instead of p/q .

NB particles in a bunch may have momenta that differ from 'p' which is the reference momentum.

Beam rigidity

For the highly-relativistic case
(often encountered)

$$E \gg m_0 c^2 \quad p \approx \frac{E}{c}$$

We can calculate the beam rigidity from the easy-to-remember equation

$$B\rho[\text{Tm}] = \frac{E_0[\text{J}]}{q[\text{C}]c[\text{m/s}]}$$

$$B\rho[\text{Tm}] = 3.3 p_0[\text{GeV}/c]$$

which is useful when working with high energy colliders, as the beam energy is often expressed in units of GeV.

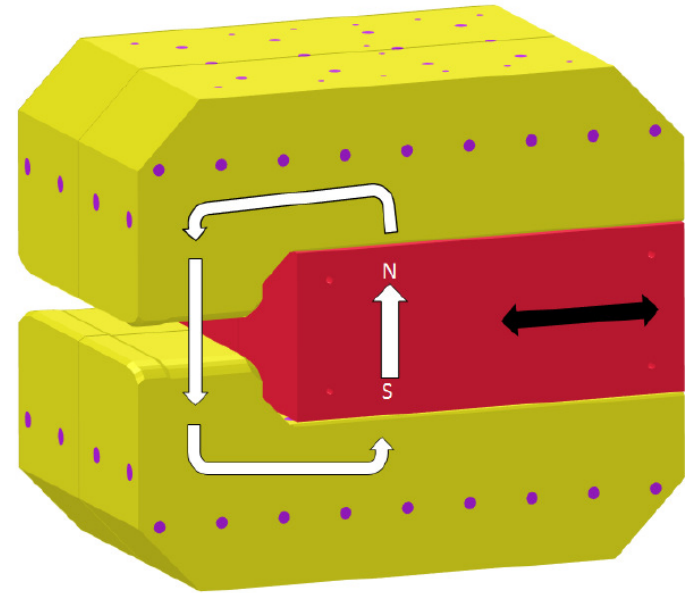

Beam rigidity

For the highly-relativistic case
(often encountered)

$$E \gg m_0 c^2 \quad p \approx \frac{E}{c}$$

We can calculate the beam rigidity from the easy-to-remember equation

$$B\rho[\text{Tm}] = \frac{E_0[\text{eV}]}{c[\text{m/s}]}$$

$$B\rho[\text{Tm}] = 3.3 p_0[\text{GeV}/c]$$

which is useful when working with high energy colliders, as the beam energy is often expressed in units of GeV.

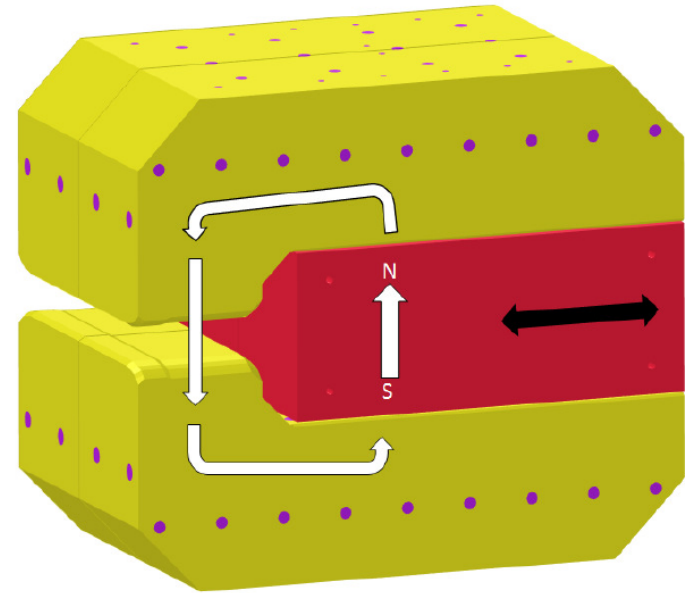

Beam rigidity

For the highly-relativistic case
(often encountered)

$$E \gg m_0 c^2 \quad p \approx \frac{E}{c}$$

We can calculate the beam rigidity from the easy-to-remember equation

$$B\rho[\text{Tm}] = \frac{E_0[\text{eV}]}{c[\text{m/s}]}$$

$$B\rho[\text{Tm}] = 3.3 p_0[\text{GeV}/c]$$

which is useful when working with high energy colliders, as the beam energy is often expressed in units of GeV.

I am using '0' here to emphasise that we are talking about the reference (design) energy and momentum.

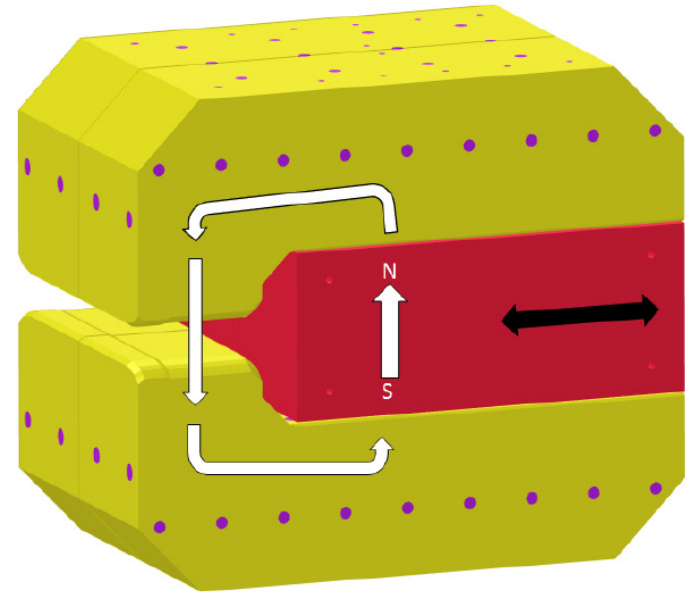

We will generally normalise magnetic field strengths to the beam rigidity, and obtain energy-independent 'k values', e.g. for a uniform B field

$$k_0 = \frac{q}{p_0} B$$

The magnetic guide field (dipole magnets)

$$B\rho = \frac{p}{q} \Rightarrow k = \frac{B}{B\rho} = \frac{1}{\rho} = \frac{qB}{p}$$

Consider the LHC design

$$B=8.3 \text{ T}$$

$$p=7000 \text{ GeV}/c$$

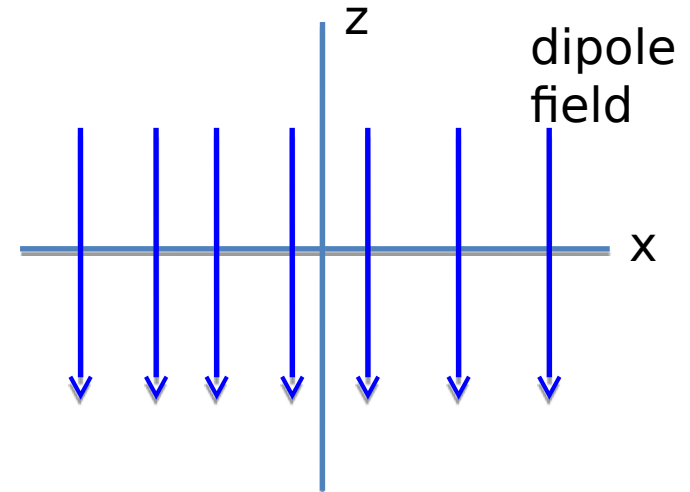
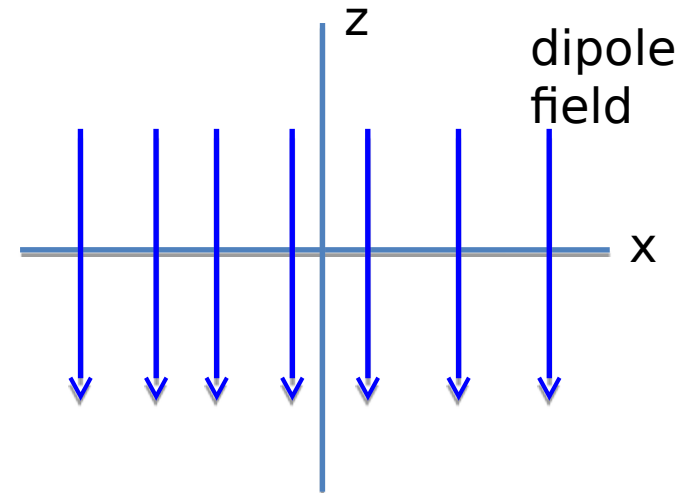

Image of a dipole magnet.

The magnetic guide field (dipole magnets)

$$B\rho = \frac{p}{q} \Rightarrow k = \frac{B}{B\rho} = \frac{1}{\rho} = \frac{qB}{p}$$



Consider the LHC design

$$B=8.3 \text{ T}$$

$$p=7000 \text{ GeV}/c$$



Image of a dipole magnet.

$$\frac{1}{\rho} = q[\text{C}] \frac{8.3[\text{Vs}/\text{m}^2]}{7000 \times 10^9[\text{eV}/c]} = \frac{8.3[\text{s}] \times 3 \times 10^8[\text{m}/\text{s}]}{7000 \times 10^9[\text{m}^2]}$$

The magnetic guide field (dipole magnets)

$$B\rho = \frac{p}{q} \Rightarrow k = \frac{B}{B\rho} = \frac{1}{\rho} = \frac{qB}{p}$$

Consider the LHC design

$$B=8.3 \text{ T}$$

$$p=7000 \text{ GeV}/c$$

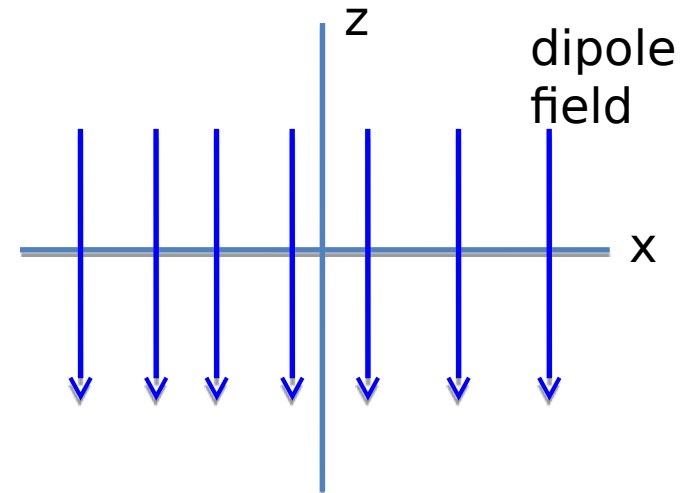

Image of a dipole magnet.

$$\frac{1}{\rho} = q[\text{C}] \frac{8.3[\text{Vs}/\text{m}^2]}{7000 \times 10^9[\text{eV}/c]} = \frac{8.3[\text{s}] \times 3 \times 10^8[\text{m}/\text{s}]}{7000 \times 10^9[\text{m}^2]}$$

$$\frac{1}{\rho} = 0.3 \frac{8.3}{7000} [\text{/m}] = 3.6 \times 10^{-4} [\text{/m}]$$

$$\Rightarrow \rho \approx 2800 \text{ m}$$

Oscillations and focusing

Consider a positively charged, constant energy particle in a fixed dipole field (into the page).

The reference particle executes 'cyclotron motion'.

Other particles of the same energy but at different starting positions execute cyclotron motion of the same radius.

Compared to the reference trajectory, this looks like an **oscillation**. This is called a **betatron oscillation**.

The number of oscillations per turn is called the 'tune'.

In this case, the tune is 1.

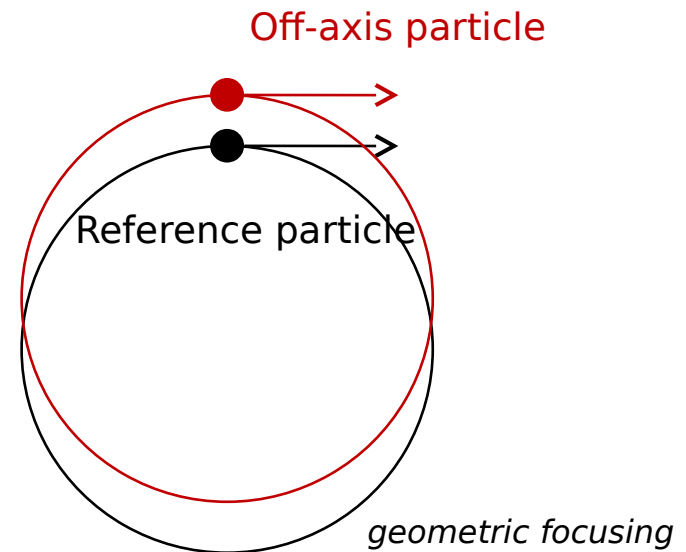

Oscillations and focusing

This effect only applies to small displacements in the horizontal position.

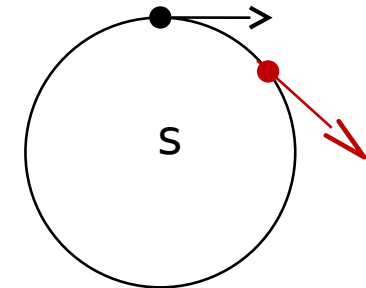
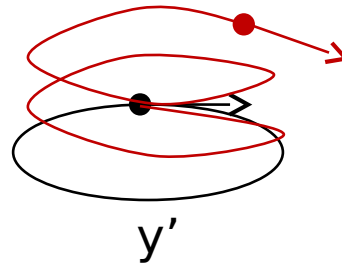
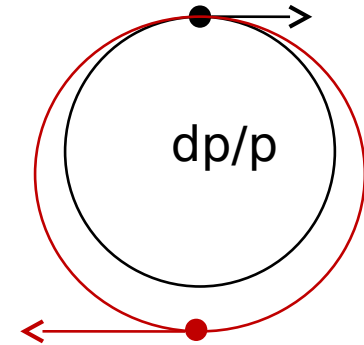
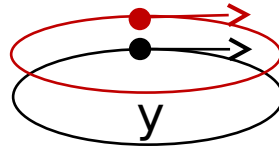
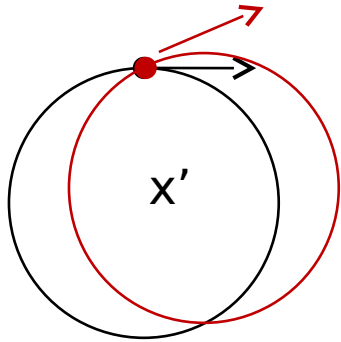

The coordinate system is x (horizontal), y (vertical), z or s (along the design orbit).

Focussing magnets

- The particles in a bunch will diverge unless focussed.
- The angle of deflection of a particle moving a distance l perpendicular to a uniform magnetic field can be found from integrating

$$\rho d\theta = ds \quad \Rightarrow \quad d\theta = \frac{ds}{\rho} \quad \rho(s) = \frac{p}{qB(s)}$$

- To get focussing in all directions we need the B field to be azimuthal around the particle trajectory. To get a focal point we need the magnetic field and deflection angle to be proportional to the radial distance from the design orbit, as in a conventional optical lens.

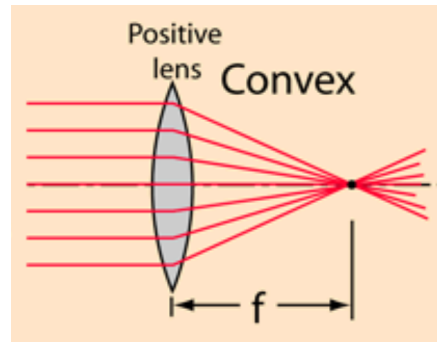

- This principle is used in specialised magnets such as Lithium lenses, but the focussing achievable is quite weak, and it requires the particle beam to pass through a physical lens.
- This isn't generally suitable for high energy particles...
- The best solution is generally to use quadrupole magnets (strong focussing).

Focussing magnets

- The particles in a bunch will diverge unless focussed.
- The angle of deflection of a particle moving a distance l perpendicular to a uniform magnetic field is

$$\theta = -\frac{q}{p} \int^l B ds$$

- To get focussing in all directions we need the B field to be azimuthal around the particle trajectory. To get a focal point we need the magnetic field and deflection angle to be proportional to the radial distance from the design orbit, as in a conventional optical lens.

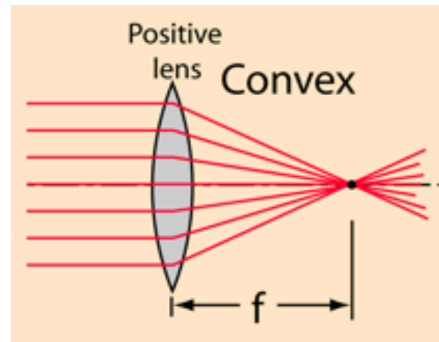

- This principle is used in specialised magnets such as Lithium lenses, but the focussing achievable is quite weak, and it requires the particle beam to pass through a physical lens.
- This isn't generally suitable for high energy particles...
- The best solution is generally to use quadrupole magnets (strong focussing).

Focussing magnets

- The particles in a bunch will diverge unless focussed.
- The angle of deflection of a particle moving a distance l perpendicular to a uniform magnetic field is

$$\theta = -\frac{q}{p} \int^l B ds$$

- To get focussing in all directions we need the B field to be azimuthal around the particle trajectory. To get a focal point we need the magnetic field and deflection angle to be proportional to the radial distance from the design orbit, as in a conventional optical lens.

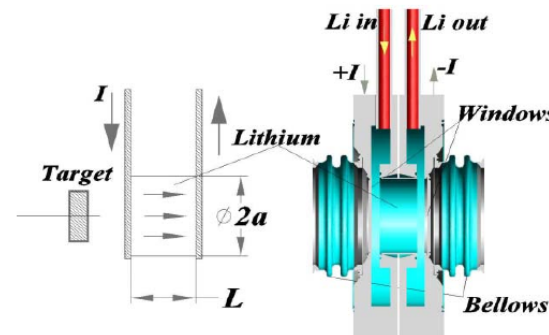

- This principle is used in specialised magnets such as **Lithium lenses**, but the focussing achievable is quite weak, and it requires the particle beam to pass through a physical lens.
- This isn't generally suitable for high energy particles...
- The best solution is generally to use quadrupole magnets (strong focussing).

Focussing magnets

- The particles in a bunch will diverge unless focussed.
- The angle of deflection of a particle moving a distance l perpendicular to a uniform magnetic field is

$$\theta = -\frac{q}{p} \int^l B ds$$

- To get focussing in all directions we need the B field to be azimuthal around the particle trajectory. To get a focal point we need the magnetic field and deflection angle to be proportional to the radial distance from the design orbit, as in a conventional optical lens.

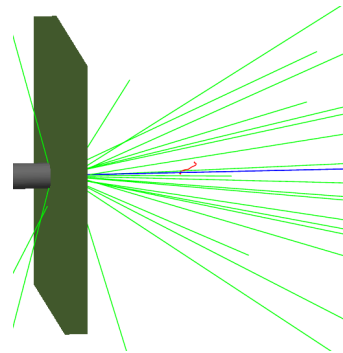

- This principle is used in specialised magnets such as Lithium lenses, but the focussing achievable is quite weak and it requires the particle beam to pass through a physical lens.
- This isn't generally suitable for **high energy particles...**
- The best solution is generally to use quadrupole magnets (strong focussing).

A (normal) quadrupole

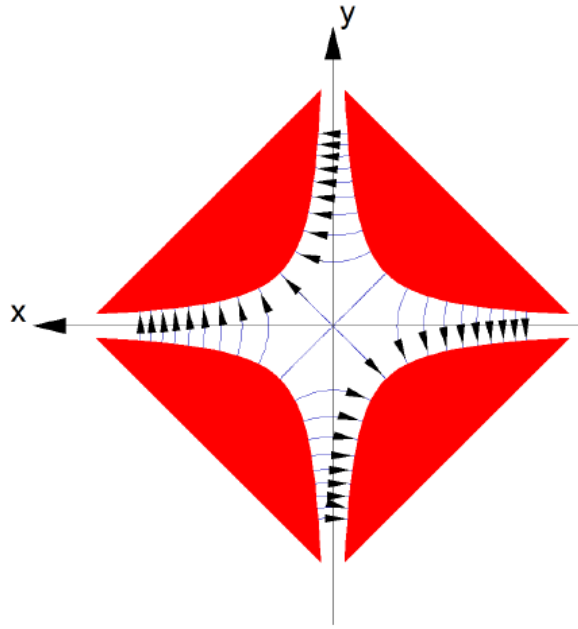

(Normalised field gradient k_1)

$$k_1 = \frac{q}{p_0} g$$

$$B_x = gy \quad B_y = gx$$

For positively charged particles moving into the page, this quadrupole (above) gives a focusing force in x . However it defocuses in y , due to Maxwell's equations. The opposite is shown in the diagram to the right.

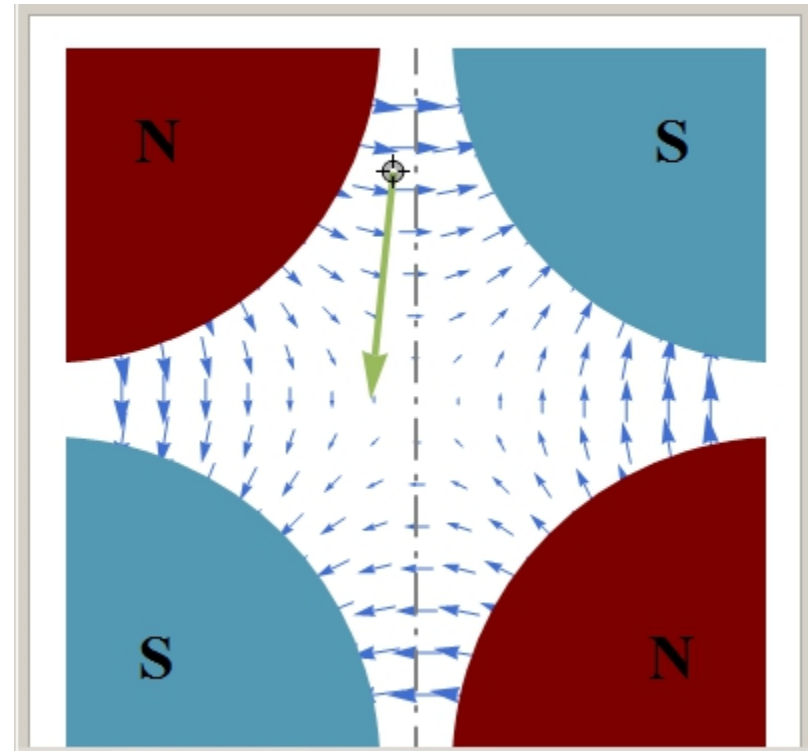

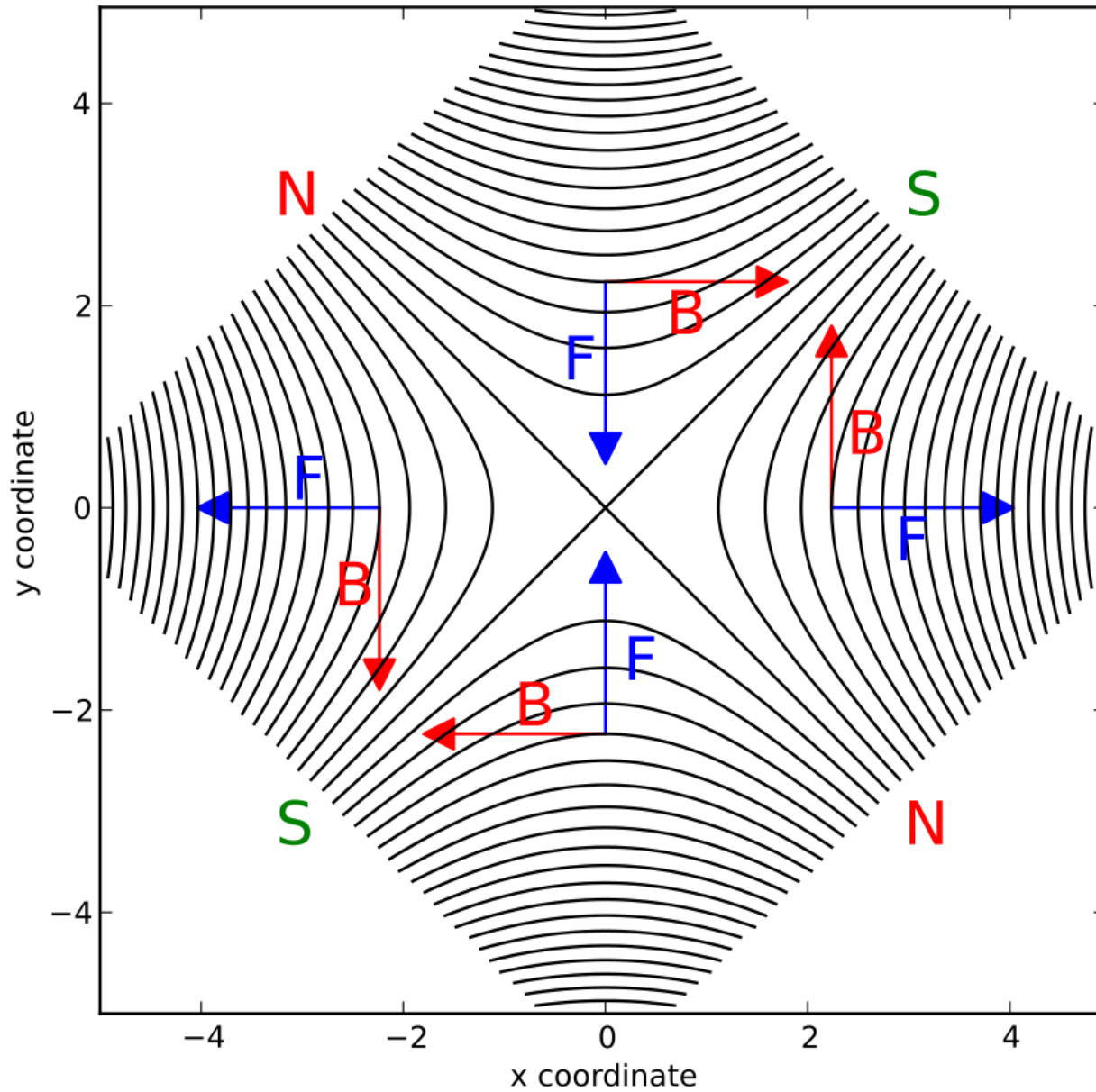

Defocuses in x for positive particle moving into page.

The expansion of the magnetic fields

We now derive the equations of motion for a particle in an accelerator containing dipoles and quadrupoles

- 1) We consider the motion of the particles w.r.t. a design orbit
- 2) We assume the deviation of the particle from this design orbit is small, so $x, y \ll$ the bending radius

Assumption (2) means that we only need to take into account linear terms in the dependence of the field B w.r.t. x and y .

So it makes sense to make a Taylor expansion of B around the design orbit and normalise to the beam rigidity. E.g.

$$B_y(x) = B_{y0} + \frac{dB_y}{dx}x + \frac{1}{2} \frac{d^2 B_y}{dx^2}x^2 + \frac{1}{3!} \frac{d^3 B_y}{dx^3}x^3 + \dots$$

$$\frac{q}{p_0} B_y(x) = \frac{q}{p_0} B_{y0} + \frac{q}{p_0} \frac{dB_y}{dx}x + \frac{q}{p_0} \frac{1}{2} \frac{d^2 B_y}{dx^2}x^2 + \frac{q}{p_0} \frac{1}{3!} \frac{d^3 B_y}{dx^3}x^3 + \dots$$

$$\frac{q}{p_0} B_y(x) = k_0 + k_1 x + k_2 x^2 + k_3 x^3 + \dots$$

The expansion of the magnetic fields

We now derive the equations of motion for a particle in an accelerator containing dipoles and quadrupoles

- 1) We consider the motion of the particles w.r.t. a design orbit
- 2) We assume the deviation of the particle from this design orbit is small, so $x, y \ll$ the bending radius

Assumption (2) means that we only need to take into account linear terms in the dependence of the field B w.r.t. x and y .

So it makes sense to make a Taylor expansion of B around the design orbit and normalise to the beam rigidity. E.g.

$$B_y(x) = B_{y0} + \frac{dB_y}{dx}x + \frac{1}{2} \frac{d^2 B_y}{dx^2}x^2 + \frac{1}{3!} \frac{d^3 B_y}{dx^3}x^3 + \dots$$

$$\frac{q}{p_0} B_y(x) = \frac{q}{p_0} B_{y0} + \frac{q}{p_0} \frac{dB_y}{dx}x + \frac{q}{p_0} \frac{1}{2} \frac{d^2 B_y}{dx^2}x^2 + \frac{q}{p_0} \frac{1}{3!} \frac{d^3 B_y}{dx^3}x^3 + \dots$$

$$\frac{q}{p_0} B_y(x) = \frac{1}{\rho} + kx + \frac{1}{2} mx^2 + \frac{1}{3!} ox^3 + \dots$$

A storage ring, with a design orbit determined by dipoles and beam focussed around the design orbit by quadrupoles.

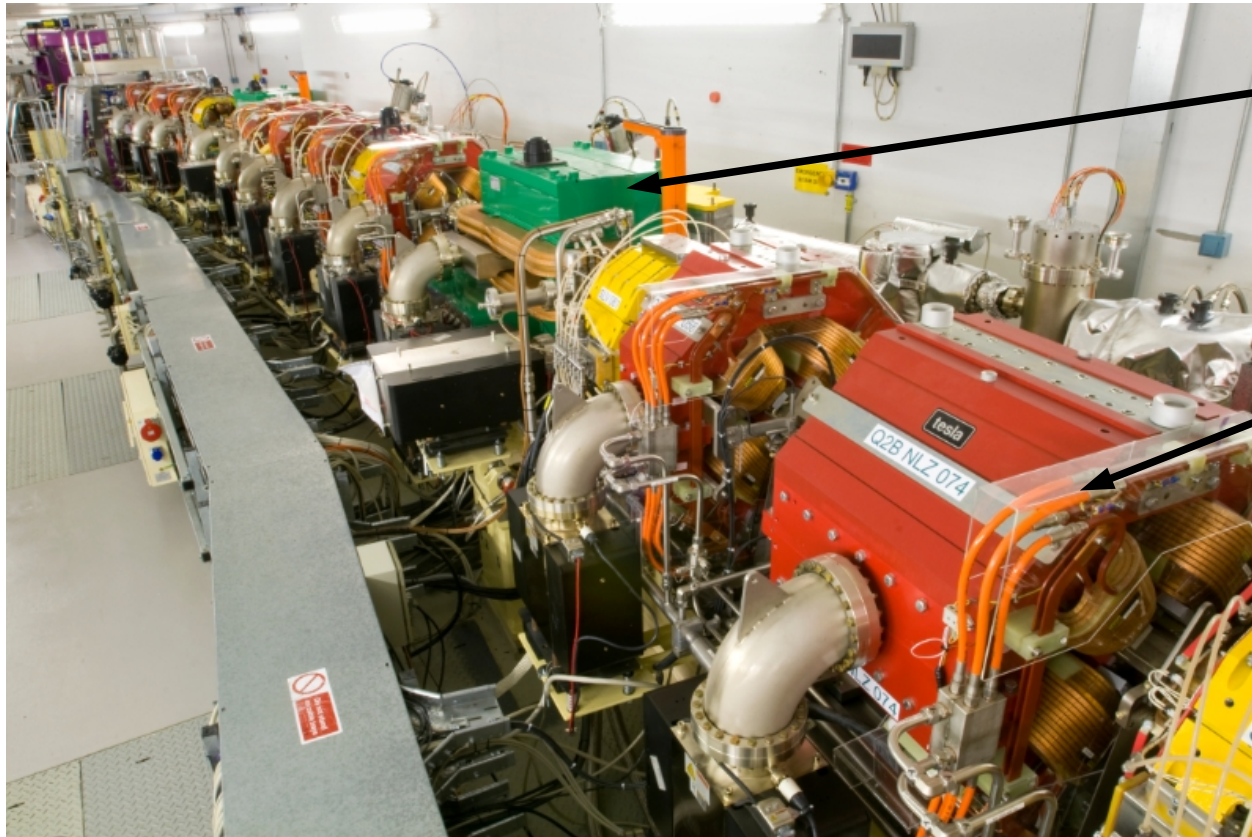

Dipole

Quadrupole

A combined function magnet

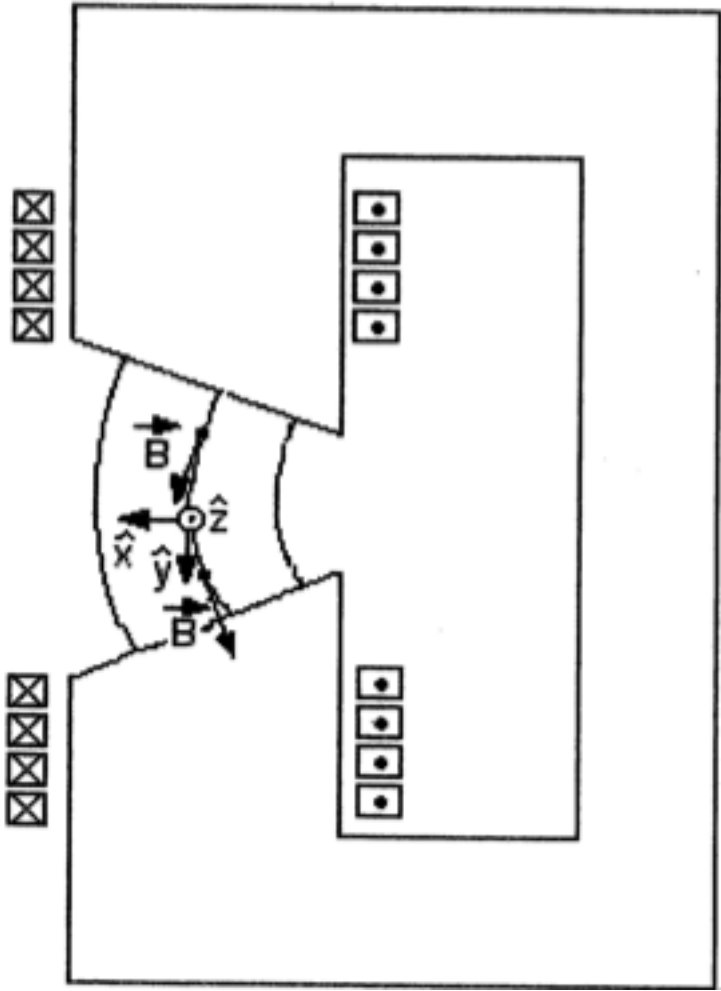

We can also provide the magnetic field gradient needed for beam focusing by tilting the magnetic pole faces of a dipole magnet.

Notice that there is a component of B such that B_x is proportional to y .

Hence this magnet has both a dipole and a quadrupole component (giving some vertical focussing): a **combined function magnet**.

(The pole face tilt must be small for stable motion. This style of focussing where the horizontal focussing is only from the dipoles, and a small amount of vertical focussing is used, is often called 'weak focusing').

The equations of motion in an accelerator

We continue to derive the equations of motion for a particle moving under the influence of dipole and quadrupole fields in an accelerator. The steps we will follow are

- 1) Define a 'curved' coordinate system and its coordinates
- 2) Calculate the position, velocity and acceleration vectors in this coordinate system. We are only concerned with the transverse motion around the design orbit, so we will discard other terms.
- 3) Use the Lorentz force law to calculate the forces on the particle, and write down an expression for the change in particle momentum.
- 4) Change the independent variable from time to position along the design orbit.
- 5) Expand the equations and approximate them as linear in x and z .
- 6) Specialise to the case of pure dipole and quadrupole fields.

The result will be two second-order ordinary differential equations (one for the horizontal plane and one for the vertical).

Our coordinate system and our coordinates (x, z, s)

When discussing motion previously we used 'y' as our vertical coordinate. In this section we use 'z'. You'll see both in the literature.

We'll use a curved coordinate system, with this curvature produced by a local dipole field.

The curved reference trajectory is normally called the **design orbit**, and the coordinate system moves with a reference particle around the design orbit defined by the **dipoles**.

We'll denote the local curvature of the orbit as ρ .

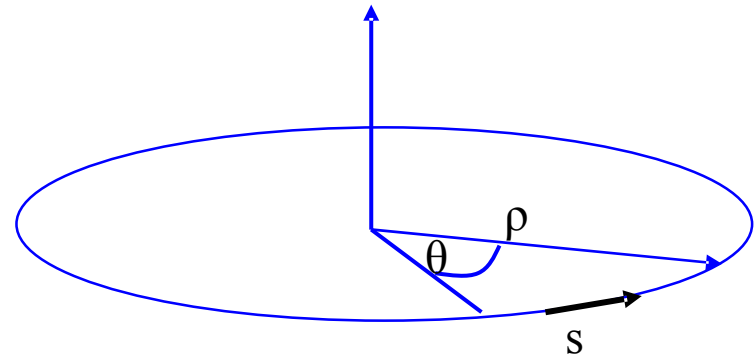

The distance along this design trajectory will be s . The total length of the design orbit is therefore

$$L = \oint ds$$

Our coordinates (x and z) represent deviations with respect to the design (**ideal**) orbit, and we assume these deviations will be small (x is typically a few millimetres).

In addition to the positions (x and z) we also consider the slopes **$dx/ds=x'$** and **$dz/ds=z'$**

Coordinates are with respect to the design orbit

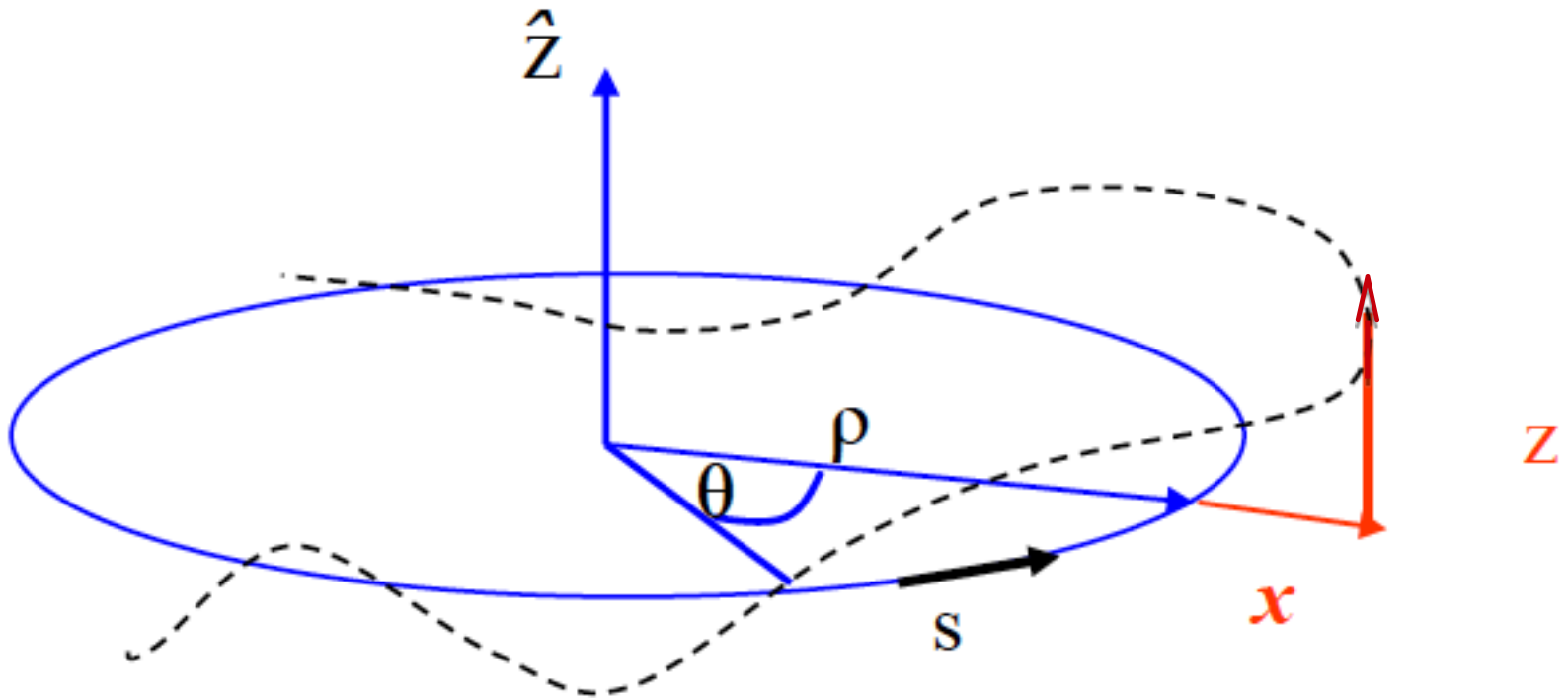

The path length along this orbit is labelled by s .

For now, we start off with time (t) as the independent variable.

At any point on the design orbit we have a coordinate system (x, z, s) .

For simplicity, we assume the design orbit lies in the horizontal plane.

Motion of unit vectors in this coordinate system

$$\vec{F} = m_0 \gamma \frac{d^2 \vec{r}}{dt^2} = q \left(\frac{d\vec{r}}{dt} \times \vec{B} \right)$$

Evaluating $\dot{\vec{r}}$ and $\ddot{\vec{r}}$ is messy.
We do it here for completeness.
We are more interested in the result than the method.

Motion of the unit vectors of our rotating coordinate system wrt static unit vectors :

$$\vec{x}(\theta) = \vec{x}(0) \cos(\theta) + \vec{s}(0) \sin(\theta)$$

$$\vec{s}(\theta) = \vec{s}(0) \cos(\theta) - \vec{x}(0) \sin(\theta)$$

} From geometry.

$$\Rightarrow \frac{d\vec{s}}{d\theta} = -\vec{x} \quad \frac{d\vec{x}}{d\theta} = \vec{s}$$

Changing the independent variable from theta to t

Convert from $\frac{d}{d\theta}$ to $\frac{d}{dt}$

$$ds = \rho d\theta \quad \Rightarrow \quad \frac{d\theta}{dt} = \frac{1}{\rho} \frac{ds}{dt}$$

$$\left\{ \begin{array}{l} \frac{d\vec{s}}{d\theta} = -\vec{x} \\ \frac{d\vec{x}}{d\theta} = \vec{s} \end{array} \right\}$$

$$\Rightarrow \frac{d\vec{x}}{dt} = \frac{d\vec{x}}{d\theta} \frac{d\theta}{dt} = \frac{1}{\rho} \frac{ds}{dt} \vec{s}$$

$$\frac{d\vec{s}}{dt} = \frac{d\vec{s}}{d\theta} \frac{d\theta}{dt} = -\frac{1}{\rho} \frac{ds}{dt} \vec{x}$$

$$\frac{d\vec{z}}{dt} = 0$$

The position vector of any particle can then be written with respect to a point \vec{r}_0 on the design orbit as

$$\vec{r} = \vec{r}_0 + \lambda \vec{x} + z \vec{z} \quad \text{where} \quad \frac{d\vec{r}_0}{dt} = \frac{ds}{dt} \vec{s}$$

Changing the independent variable from theta to t

Convert from $\frac{d}{d\theta}$ to $\frac{d}{dt}$

$$ds = \rho d\theta \quad \Rightarrow \quad \frac{d\theta}{dt} = \frac{1}{\rho} \frac{ds}{dt}$$

$$\left\{ \frac{d\vec{s}}{d\theta} = -\vec{x} \quad \left\{ \frac{d\vec{x}}{d\theta} = \vec{s} \right. \right\}$$

$$\Rightarrow \frac{d\vec{x}}{dt} = \frac{d\vec{x}}{d\theta} \frac{d\theta}{dt} = \frac{1}{\rho} \frac{ds}{dt} \vec{s}$$

$$\frac{d\vec{s}}{dt} = \frac{d\vec{s}}{d\theta} \frac{d\theta}{dt} = -\frac{1}{\rho} \frac{ds}{dt} \vec{x}$$

$$\frac{d\vec{z}}{dt} = 0$$

The position vector of any particle can then be written with respect to a point \vec{r}_0 on the design orbit as

$$\vec{r} = \vec{r}_0 + x\vec{x} + z\vec{z} \quad \text{where} \quad \frac{d\vec{r}_0}{dt} = \frac{ds}{dt} \vec{s}$$

Changing the independent variable from theta to t

Convert from $\frac{d}{d\theta}$ to $\frac{d}{dt}$

$$ds = \rho d\theta \quad \Rightarrow \quad \frac{d\theta}{dt} = \frac{1}{\rho} \frac{ds}{dt}$$

$$\left. \begin{aligned} \frac{d\vec{s}}{d\theta} &= -\vec{x} \\ \frac{d\vec{x}}{d\theta} &= \vec{s} \end{aligned} \right\}$$

$$\Rightarrow \frac{d\vec{x}}{dt} = \frac{d\vec{x}}{d\theta} \frac{d\theta}{dt} = \frac{1}{\rho} \frac{ds}{dt} \vec{s}$$

$$\frac{d\vec{s}}{dt} = \frac{d\vec{s}}{d\theta} \frac{d\theta}{dt} = -\frac{1}{\rho} \frac{ds}{dt} \vec{x}$$

$$\frac{d\vec{z}}{dt} = 0$$

The position vector of any particle can then be written with respect to a point \vec{r}_0 on the design orbit as

$$\vec{\mathbf{r}} = \vec{\mathbf{r}}_0 + \lambda \vec{\mathbf{X}} + z \vec{\mathbf{Z}} \quad \text{where} \quad \frac{d\vec{\mathbf{r}}_0}{dt} = \frac{ds}{dt} \vec{\mathbf{s}}$$

Velocity and acceleration in the comoving frame

$$\vec{r} = \vec{r}_0 + x\vec{x} + z\vec{z}$$

$$\begin{aligned}\Rightarrow \frac{d\vec{r}}{dt} &= \frac{ds}{dt}\vec{s} + \frac{dx}{dt}\vec{x} + \frac{dz}{dt}\vec{z} + \frac{x}{\rho} \frac{ds}{dt}\vec{s} \\ &= \frac{dx}{dt}\vec{x} + \frac{dz}{dt}\vec{z} + \left(1 + \frac{x}{\rho}\right) \frac{ds}{dt}\vec{s}\end{aligned}$$

$$\Rightarrow \frac{d^2\vec{r}}{dt^2} = \left(\frac{d^2x}{dt^2} - \left(1 + \frac{x}{\rho}\right) \frac{1}{\rho} \left(\frac{ds}{dt}\right)^2 \right) \vec{x}$$

$$+ \frac{d^2z}{dt^2} \vec{z}$$

$$+ \left(\frac{2}{\rho} \frac{dx}{dt} \frac{ds}{dt} + \left(1 + \frac{x}{\rho}\right) \frac{d^2s}{dt^2} \right) \vec{s}$$

Evaluate the first and second derivatives with respect to time...

Now we make one last transformation. Instead of using the derivative with respect to time for 'x' and 'z', we can use the derivative with respect to 's'.

Velocity and acceleration in the comoving frame

$$\vec{r} = \vec{r}_0 + x\vec{x} + z\vec{z}$$

$$\Rightarrow \frac{d\vec{r}}{dt} = \frac{ds}{dt}\vec{s} + \frac{dx}{dt}\vec{x} + \frac{dz}{dt}\vec{z} + \frac{x}{\rho} \frac{ds}{dt}\vec{s}$$

$$= \frac{dx}{dt}\vec{x} + \frac{dz}{dt}\vec{z} + \left(1 + \frac{x}{\rho}\right) \frac{ds}{dt}\vec{s}$$

$$\Rightarrow \frac{d^2\vec{r}}{dt^2} = \left(\frac{d^2x}{dt^2} - \left(1 + \frac{x}{\rho}\right) \frac{1}{\rho} \left(\frac{ds}{dt}\right)^2 \right) \vec{x}$$

$$+ \frac{d^2z}{dt^2} \vec{z}$$

$$+ \left(\frac{2}{\rho} \frac{dx}{dt} \frac{ds}{dt} + \left(1 + \frac{x}{\rho}\right) \frac{d^2s}{dt^2} \right) \vec{s}$$

Evaluate the first and second derivatives with respect to time...

Now we make one last transformation. Instead of using the derivative with respect to time for 'x' and 'z', we can use the derivative with respect to 's'.

Velocity and acceleration in the comoving frame

$$\vec{r} = \vec{r}_0 + x\vec{\bar{x}} + z\vec{\bar{z}}$$

$$\begin{aligned} \Rightarrow \frac{d\vec{r}}{dt} &= \frac{ds}{dt}\vec{\bar{s}} + \frac{dx}{dt}\vec{\bar{x}} + \frac{dz}{dt}\vec{\bar{z}} + \frac{x}{\rho} \frac{ds}{dt}\vec{\bar{s}} \\ &= \frac{dx}{dt}\vec{\bar{x}} + \frac{dz}{dt}\vec{\bar{z}} + \left(1 + \frac{x}{\rho}\right) \frac{ds}{dt}\vec{\bar{s}} \end{aligned}$$

$$\Rightarrow \frac{d^2\vec{r}}{dt^2} = \left(\frac{d^2x}{dt^2} - \left(1 + \frac{x}{\rho}\right) \frac{1}{\rho} \left(\frac{ds}{dt}\right)^2 \right) \vec{\bar{x}}$$

$$+ \frac{d^2z}{dt^2} \vec{\bar{z}}$$

$$+ \left(\frac{2}{\rho} \frac{dx}{dt} \frac{ds}{dt} + \left(1 + \frac{x}{\rho}\right) \frac{d^2s}{dt^2} \right) \vec{\bar{s}}$$

Evaluate the first and second derivatives with respect to time...

Now we make one last transformation. Instead of using the derivative with respect to time for 'x' and 'z', we can use the derivative with respect to 's'.

Velocity and acceleration in the comoving frame

$$\vec{r} = \vec{r}_0 + x\vec{x} + z\vec{z}$$

$$\begin{aligned} \Rightarrow \frac{d\vec{r}}{dt} &= \frac{ds}{dt}\vec{s} + \frac{dx}{dt}\vec{x} + \frac{dz}{dt}\vec{z} + \frac{x}{\rho} \frac{ds}{dt}\vec{s} \\ &= \frac{dx}{dt}\vec{x} + \frac{dz}{dt}\vec{z} + \left(1 + \frac{x}{\rho}\right) \frac{ds}{dt}\vec{s} \end{aligned}$$

$$\Rightarrow \frac{d^2\vec{r}}{dt^2} = \left(\frac{d^2x}{dt^2} - \left(1 + \frac{x}{\rho}\right) \frac{1}{\rho} \left(\frac{ds}{dt}\right)^2 \right) \vec{x}$$

$$+ \frac{d^2z}{dt^2} \vec{z}$$

$$+ \left(\frac{2}{\rho} \frac{dx}{dt} \frac{ds}{dt} + \left(1 + \frac{x}{\rho}\right) \frac{d^2s}{dt^2} \right) \vec{s}$$

Evaluate the first and second derivatives with respect to time...

Now we make one last transformation. Instead of using the derivative with respect to time for 'x' and 'z', we can use the derivative with respect to 's'.

Velocity and acceleration in the comoving frame

$$\vec{r} = \vec{r}_0 + x\vec{\bar{x}} + z\vec{\bar{z}}$$

$$\begin{aligned} \Rightarrow \frac{d\vec{r}}{dt} &= \frac{ds}{dt}\vec{\bar{s}} + \frac{dx}{dt}\vec{\bar{x}} + \frac{dz}{dt}\vec{\bar{z}} + \frac{x}{\rho} \frac{ds}{dt}\vec{\bar{s}} \\ &= \frac{dx}{dt}\vec{\bar{x}} + \frac{dz}{dt}\vec{\bar{z}} + \left(1 + \frac{x}{\rho}\right) \frac{ds}{dt}\vec{\bar{s}} \end{aligned}$$

$$\Rightarrow \frac{d^2\vec{r}}{dt^2} = \left(\frac{d^2x}{dt^2} - \left(1 + \frac{x}{\rho}\right) \frac{1}{\rho} \left(\frac{ds}{dt}\right)^2 \right) \vec{\bar{x}}$$

$$+ \frac{d^2z}{dt^2} \vec{\bar{z}}$$

$$+ \left(\frac{2}{\rho} \frac{dx}{dt} \frac{ds}{dt} + \left(1 + \frac{x}{\rho}\right) \frac{d^2s}{dt^2} \right) \vec{\bar{s}}$$

Evaluate the first and second derivatives with respect to time...

Now we make one last transformation. Instead of using the derivative with respect to time for 'x' and 'z', we can use the derivative with respect to 's'.

Velocity and acceleration in the comoving frame

$$\vec{r} = \vec{r}_0 + x\vec{\bar{x}} + z\vec{\bar{z}}$$

$$\begin{aligned} \Rightarrow \frac{d\vec{r}}{dt} &= \frac{ds}{dt}\vec{\bar{s}} + \frac{dx}{dt}\vec{\bar{x}} + \frac{dz}{dt}\vec{\bar{z}} + \frac{x}{\rho} \frac{ds}{dt}\vec{\bar{s}} \\ &= \frac{dx}{dt}\vec{\bar{x}} + \frac{dz}{dt}\vec{\bar{z}} + \left(1 + \frac{x}{\rho}\right) \frac{ds}{dt}\vec{\bar{s}} \end{aligned}$$

$$\Rightarrow \frac{d^2\vec{r}}{dt^2} = \left(\frac{d^2x}{dt^2} - \left(1 + \frac{x}{\rho}\right) \frac{1}{\rho} \left(\frac{ds}{dt}\right)^2 \right) \vec{\bar{x}}$$

$$+ \frac{d^2z}{dt^2} \vec{\bar{z}}$$

$$+ \left(\frac{2}{\rho} \frac{dx}{dt} \frac{ds}{dt} + \left(1 + \frac{x}{\rho}\right) \frac{d^2s}{dt^2} \right) \vec{\bar{s}}$$

Evaluate the first and second derivatives with respect to time...

Now we make one last transformation. Instead of using the derivative with respect to time for 'x' and 'z', we can use the derivative with respect to 's'.

Velocity and acceleration in the comoving frame

$$\vec{r} = \vec{r}_0 + x\vec{\bar{x}} + z\vec{\bar{z}}$$

$$\begin{aligned} \Rightarrow \frac{d\vec{r}}{dt} &= \frac{ds}{dt}\vec{\bar{s}} + \frac{dx}{dt}\vec{\bar{x}} + \frac{dz}{dt}\vec{\bar{z}} + \frac{x}{\rho} \frac{ds}{dt}\vec{\bar{s}} \\ &= \frac{dx}{dt}\vec{\bar{x}} + \frac{dz}{dt}\vec{\bar{z}} + \left(1 + \frac{x}{\rho}\right) \frac{ds}{dt}\vec{\bar{s}} \end{aligned}$$

$$\Rightarrow \frac{d^2\vec{r}}{dt^2} = \left(\frac{d^2x}{dt^2} - \left(1 + \frac{x}{\rho}\right) \frac{1}{\rho} \left(\frac{ds}{dt}\right)^2 \right) \vec{\bar{x}}$$

$$+ \frac{d^2z}{dt^2} \vec{\bar{z}}$$

$$+ \left(\frac{2}{\rho} \frac{dx}{dt} \frac{ds}{dt} + \left(1 + \frac{x}{\rho}\right) \frac{d^2s}{dt^2} \right) \vec{\bar{s}}$$

Evaluate the first and second derivatives with respect to time...

Now we make one last transformation. Instead of using the derivative with respect to time for 'x' and 'z', we can use the derivative with respect to 's'.

Velocity and acceleration in the comoving frame

$$\vec{r} = \vec{r}_0 + x\vec{x} + z\vec{z}$$

$$\begin{aligned} \Rightarrow \frac{d\vec{r}}{dt} &= \frac{ds}{dt}\vec{s} + \frac{dx}{dt}\vec{x} + \frac{dz}{dt}\vec{z} + \frac{x}{\rho} \frac{ds}{dt}\vec{s} \\ &= \frac{dx}{dt}\vec{x} + \frac{dz}{dt}\vec{z} + \left(1 + \frac{x}{\rho}\right) \frac{ds}{dt}\vec{s} \end{aligned}$$

$$\Rightarrow \frac{d^2\vec{r}}{dt^2} = \left(\frac{d^2x}{dt^2} - \left(1 + \frac{x}{\rho}\right) \frac{1}{\rho} \left(\frac{ds}{dt}\right)^2 \right) \vec{x}$$

$$+ \frac{d^2z}{dt^2} \vec{z}$$

$$+ \left(\frac{2}{\rho} \frac{dx}{dt} \frac{ds}{dt} + \left(1 + \frac{x}{\rho}\right) \frac{d^2s}{dt^2} \right) \vec{s}$$

Evaluate the first and second derivatives with respect to time...

Now we make one last transformation. Instead of using the derivative with respect to time for 'x' and 'z', we can use the derivative with respect to 's'.

Velocity and acceleration in the comoving frame

$$\vec{r} = \vec{r}_0 + x\vec{\bar{x}} + z\vec{\bar{z}}$$

$$\begin{aligned} \Rightarrow \frac{d\vec{r}}{dt} &= \frac{ds}{dt}\vec{\bar{s}} + \frac{dx}{dt}\vec{\bar{x}} + \frac{dz}{dt}\vec{\bar{z}} + \frac{x}{\rho} \frac{ds}{dt}\vec{\bar{s}} \\ &= \frac{dx}{dt}\vec{\bar{x}} + \frac{dz}{dt}\vec{\bar{z}} + \left(1 + \frac{x}{\rho}\right) \frac{ds}{dt}\vec{\bar{s}} \end{aligned}$$

$$\Rightarrow \frac{d^2\vec{r}}{dt^2} = \left(\frac{d^2x}{dt^2} - \left(1 + \frac{x}{\rho}\right) \frac{1}{\rho} \left(\frac{ds}{dt}\right)^2 \right) \vec{\bar{x}}$$

$$+ \frac{d^2z}{dt^2} \vec{\bar{z}}$$

$$+ \left(\frac{2}{\rho} \frac{dx}{dt} \frac{ds}{dt} + \left(1 + \frac{x}{\rho}\right) \frac{d^2s}{dt^2} \right) \vec{\bar{s}}$$

Evaluate the first and second derivatives with respect to time...

Now we make one last transformation. Instead of using the derivative with respect to time for 'x' and 'z', we can use the derivative with respect to 's'.

Velocity and acceleration in the comoving frame

$$\vec{r} = \vec{r}_0 + x\vec{\bar{x}} + z\vec{\bar{z}}$$

$$\begin{aligned}\Rightarrow \frac{d\vec{r}}{dt} &= \frac{ds}{dt}\vec{\bar{s}} + \frac{dx}{dt}\vec{\bar{x}} + \frac{dz}{dt}\vec{\bar{z}} + \frac{x}{\rho} \frac{ds}{dt}\vec{\bar{s}} \\ &= \frac{dx}{dt}\vec{\bar{x}} + \frac{dz}{dt}\vec{\bar{z}} + \left(1 + \frac{x}{\rho}\right) \frac{ds}{dt}\vec{\bar{s}}\end{aligned}$$

$$\Rightarrow \frac{d^2\vec{r}}{dt^2} = \left(\frac{d^2x}{dt^2} - \left(1 + \frac{x}{\rho}\right) \frac{1}{\rho} \left(\frac{ds}{dt}\right)^2 \right) \vec{\bar{x}}$$

$$+ \frac{d^2z}{dt^2} \vec{\bar{z}}$$

$$+ \left(\frac{2}{\rho} \frac{dx}{dt} \frac{ds}{dt} + \left(1 + \frac{x}{\rho}\right) \frac{d^2s}{dt^2} \right) \vec{\bar{s}}$$

Evaluate the first and second derivatives with respect to time...

Now we make one last transformation. Instead of using the derivative with respect to time for 'x' and 'z', we can use the derivative with respect to 's'.

Velocity and acceleration in the comoving frame

$$\vec{r} = \vec{r}_0 + x\vec{\mathbf{x}} + z\vec{\mathbf{z}}$$

$$\begin{aligned}\Rightarrow \frac{d\vec{r}}{dt} &= \frac{ds}{dt}\vec{\mathbf{s}} + \frac{dx}{dt}\vec{\mathbf{x}} + \frac{dz}{dt}\vec{\mathbf{z}} + \frac{x}{\rho} \frac{ds}{dt}\vec{\mathbf{s}} \\ &= \frac{dx}{dt}\vec{\mathbf{x}} + \frac{dz}{dt}\vec{\mathbf{z}} + \left(1 + \frac{x}{\rho}\right) \frac{ds}{dt}\vec{\mathbf{s}}\end{aligned}$$

$$\Rightarrow \frac{d^2\vec{r}}{dt^2} = \left(\frac{d^2x}{dt^2} - \left(1 + \frac{x}{\rho}\right) \frac{1}{\rho} \left(\frac{ds}{dt}\right)^2 \right) \vec{\mathbf{x}}$$

$$+ \frac{d^2z}{dt^2} \vec{\mathbf{z}}$$

$$+ \left(\frac{2}{\rho} \frac{dx}{dt} \frac{ds}{dt} + \left(1 + \frac{x}{\rho}\right) \frac{d^2s}{dt^2} \right) \vec{\mathbf{s}}$$

Evaluate the first and second derivatives with respect to time...

Now we make one last transformation. Instead of using the derivative with respect to time for 'x' and 'z', we can use the derivative with respect to 's'.



Changing the independent variable from time to path length

$$\frac{dx}{dt} = \frac{dx}{ds} \frac{ds}{dt}, \quad \frac{d^2x}{dt^2} = \frac{d^2x}{ds^2} \left(\frac{ds}{dt} \right)^2 + \frac{dx}{ds} \frac{d^2s}{dt^2}$$

...and the same for z of course.

$$\frac{d\vec{r}}{dt} = \frac{dx}{dt} \vec{x} + \frac{dz}{dt} \vec{z} + \left(1 + \frac{x}{\rho}\right) \frac{ds}{dt} \vec{s}$$

$$\Rightarrow \frac{d\vec{r}}{dt} = \frac{dx}{ds} \frac{ds}{dt} \vec{x} + \frac{dz}{ds} \frac{ds}{dt} \vec{z} + \left(1 + \frac{x}{\rho}\right) \frac{ds}{dt} \vec{s}$$

Changing the independent variable from time to path length

$$\frac{dx}{dt} = \frac{dx}{ds} \frac{ds}{dt}, \quad \frac{d^2x}{dt^2} = \frac{d^2x}{ds^2} \left(\frac{ds}{dt} \right)^2 + \frac{dx}{ds} \frac{d^2s}{dt^2}$$

...and the same for z of course.

$$\frac{d\vec{r}}{dt} = \frac{dx}{ds} \frac{ds}{dt} \vec{x} + \frac{dz}{ds} \frac{ds}{dt} \vec{z} + \left(1 + \frac{x}{\rho}\right) \frac{ds}{dt} \vec{s}$$

$$\frac{d^2\vec{r}}{dt^2} = \left(\frac{d^2x}{dt^2} - \left(1 + \frac{x}{\rho}\right) \frac{1}{\rho} \left(\frac{ds}{dt} \right)^2 \right) \vec{x} + \dots$$

For simplicity, we'll just look at the first term of the second derivative we obtained previously.

$$\frac{d^2\vec{r}}{dt^2} = \left(\frac{d^2x}{ds^2} \left(\frac{ds}{dt} \right)^2 + \frac{dx}{ds} \frac{d^2s}{dt^2} - \left(\frac{1}{\rho} + \frac{x}{\rho^2} \right) \left(\frac{ds}{dt} \right)^2 \right) \vec{x} + \dots$$

We repeat this for the other components to get the expression on the next slide.

Changing the independent variable from time to path length

$$\frac{dx}{dt} = \frac{dx}{ds} \frac{ds}{dt}, \quad \frac{d^2x}{dt^2} = \frac{d^2x}{ds^2} \left(\frac{ds}{dt} \right)^2 + \frac{dx}{ds} \frac{d^2s}{dt^2}$$

$$\Rightarrow \frac{d\vec{\mathbf{r}}}{dt} = \frac{dx}{ds} \frac{ds}{dt} \vec{\mathbf{x}} + \frac{dz}{ds} \frac{ds}{dt} \vec{\mathbf{z}} + \left(1 + \frac{x}{\rho} \right) \frac{ds}{dt} \vec{\mathbf{s}}$$

$$\Rightarrow \frac{d^2\vec{\mathbf{r}}}{dt^2} = \left(\frac{d^2x}{ds^2} \left(\frac{ds}{dt} \right)^2 + \frac{dx}{ds} \frac{d^2s}{dt^2} - \left(\frac{1}{\rho} + \frac{x}{\rho^2} \right) \left(\frac{ds}{dt} \right)^2 \right) \vec{\mathbf{x}}$$

$$+ \left(\frac{d^2z}{ds^2} \left(\frac{ds}{dt} \right)^2 + \frac{dz}{ds} \frac{d^2s}{dt^2} \right) \vec{\mathbf{z}}$$

$$+ \left(\frac{2}{\rho} \frac{dx}{ds} \left(\frac{ds}{dt} \right)^2 + \left(1 + \frac{x}{\rho} \right) \frac{d^2s}{dt^2} \right) \vec{\mathbf{s}}$$

Changing the independent variable from time to path length

$$\frac{dx}{dt} = \frac{dx}{ds} \frac{ds}{dt}, \quad \frac{d^2x}{dt^2} = \frac{d^2x}{ds^2} \left(\frac{ds}{dt} \right)^2 + \frac{dx}{ds} \frac{d^2s}{dt^2}$$

$$\Rightarrow \frac{d\vec{r}}{dt} = \frac{dx}{ds} \frac{ds}{dt} \vec{x} + \frac{dz}{ds} \frac{ds}{dt} \vec{z} + \left(1 + \frac{x}{\rho} \right) \frac{ds}{dt} \vec{s}$$

$$\Rightarrow \frac{d^2\vec{r}}{dt^2} = \left(\frac{d^2x}{ds^2} \left(\frac{ds}{dt} \right)^2 + \frac{dx}{ds} \frac{d^2s}{dt^2} - \left(\frac{1}{\rho} + \frac{x}{\rho^2} \right) \left(\frac{ds}{dt} \right)^2 \right) \vec{x}$$

$$+ \left(\frac{d^2z}{ds^2} \left(\frac{ds}{dt} \right)^2 + \frac{dz}{ds} \frac{d^2s}{dt^2} \right) \vec{z}$$

$$+ \left(\frac{2}{\rho} \frac{dx}{ds} \left(\frac{ds}{dt} \right)^2 + \left(1 + \frac{x}{\rho} \right) \frac{d^2s}{dt^2} \right) \vec{s}$$

Ignoring any rapid changes in the velocity of the particles as they pass through the magnetic fields, we can drop terms proportional to

Changing the independent variable from time to path length

$$\frac{dx}{dt} = \frac{dx}{ds} \frac{ds}{dt}, \quad \frac{d^2x}{dt^2} = \frac{d^2x}{ds^2} \left(\frac{ds}{dt} \right)^2 + \frac{dx}{ds} \frac{d^2s}{dt^2}$$

$$\Rightarrow \frac{d\vec{r}}{dt} = \frac{dx}{ds} \frac{ds}{dt} \vec{x} + \frac{dz}{ds} \frac{ds}{dt} \vec{z} + \left(1 + \frac{x}{\rho} \right) \frac{ds}{dt} \vec{s}$$

$$\Rightarrow \frac{d^2\vec{r}}{dt^2} = \left(\frac{d^2x}{ds^2} \left(\frac{ds}{dt} \right)^2 + \frac{dx}{ds} \frac{d^2s}{dt^2} - \left(\frac{1}{\rho} + \frac{x}{\rho^2} \right) \left(\frac{ds}{dt} \right)^2 \right) \vec{x}$$

$$+ \left(\frac{d^2z}{ds^2} \left(\frac{ds}{dt} \right)^2 + \frac{dz}{ds} \frac{d^2s}{dt^2} \right) \vec{z}$$

$$+ \left(\frac{2}{\rho} \frac{dx}{ds} \left(\frac{ds}{dt} \right)^2 + \left(1 + \frac{x}{\rho} \right) \frac{d^2s}{dt^2} \right) \vec{s}$$

Ignoring any rapid changes in the velocity of the particles as they pass through the magnetic fields, we can drop terms proportional to

That gives us everything we need for the Lorentz force equation apart from the B field.

Dipole and quadrupole fields

Now, consider a linearised magnetic field (dipoles and quadrupoles only)

Recall

- we assume the dipole magnets are providing horizontal bending only
- the quadrupole focuses in the x-s plane if $k < 0$ and focuses in the z-s plane if $k > 0$

$$B = \begin{pmatrix} gz \\ 0 \\ B_{z0} + gx \end{pmatrix} = \begin{pmatrix} \frac{p_0}{q} kz \\ 0 \\ \frac{p_0}{q} \left(\frac{1}{\rho} + kx \right) \end{pmatrix}$$

$$g = \partial B_z / \partial x = \partial B_x / \partial z$$

$$k = \frac{g}{B\rho}$$

In some books it's assumed that the particles are electrons and hence $q = -e$ which changes the sign of k .

Equations of motion in dipole and quadrupole fields

Combining our equations for the velocity, acceleration and linearised magnetic field, we have

$$m_0\gamma \frac{d^2\vec{\mathbf{r}}}{dt^2} = -e \frac{d\vec{\mathbf{r}}}{dt} \times \vec{\mathbf{B}}$$

Acceleration in the 's' direction due to the magnetic field will be negligible.
We ignore it here...

$$\Rightarrow \frac{d^2\vec{\mathbf{r}}}{dt^2} = \frac{-e}{m_0\gamma} \begin{pmatrix} \frac{p_0}{e} \left(1 + \frac{x}{\rho}\right) \left(\frac{1}{\rho} + kx\right) \frac{ds}{dt} \\ ? \\ -\frac{p_0}{e} kz \left(1 + \frac{x}{\rho}\right) \frac{ds}{dt} \end{pmatrix}$$

Equations of motion in dipole and quadrupole fields

Combining our equations for the velocity, acceleration and linearised magnetic field, we have

$$\Rightarrow \frac{d^2 \vec{\mathbf{r}}}{dt^2} = \frac{-e}{m_0 \gamma} \begin{pmatrix} \frac{P_0}{e} \left(1 + \frac{x}{\rho}\right) \left(\frac{1}{\rho} + kx\right) \frac{ds}{dt} \\ ? \\ -\frac{P_0}{e} kz \left(1 + \frac{x}{\rho}\right) \frac{ds}{dt} \end{pmatrix}$$

$p = \gamma m_0 v$

$v \approx \frac{ds}{dt} \frac{\rho + x}{\rho}$

Consider z motion first

$$\left(\frac{ds}{dt}\right)^2 \frac{d^2 z}{ds^2} = \left(1 + \frac{x}{\rho}\right) kz \frac{p_0 v}{p} \frac{ds}{dt} \approx \left(1 + \frac{x}{\rho}\right)^2 kz \left(\frac{ds}{dt}\right)^2$$

$$\Rightarrow \frac{d^2 z}{ds^2} - kz \approx 0$$

NB x and z are small.

Equations of motion in dipole and quadrupole fields

Now consider x motion

$$\left(\frac{ds}{dt}\right)^2 \left(\frac{d^2x}{ds^2} - \left(\frac{1}{\rho} + \frac{x}{\rho^2}\right)\right) = -\left(1 + \frac{x}{\rho}\right)\left(\frac{1}{\rho} + kx\right) \left(\frac{p_0}{p}\right) v \frac{ds}{dt}$$

$$\Delta p = p - p_0 \longrightarrow \frac{p_0}{p} \approx \left(1 - \frac{\Delta p}{p_0}\right)$$

$$v \approx \frac{ds}{dt} \frac{\rho + x}{\rho}$$

$$\Rightarrow \frac{d^2x}{ds^2} + \left(\frac{1}{\rho^2} + k\right) x \approx \frac{1}{\rho} \frac{\Delta p}{p} \approx 0$$

Assume $\Delta p \ll p$

Note that in general ρ and k are functions of s .

Equations of motion in dipole and quadrupole fields

Now consider x motion

$$\left(\frac{ds}{dt}\right)^2 \left(\frac{d^2x}{ds^2} - \left(\frac{1}{\rho} + \frac{x}{\rho^2}\right)\right) = -\left(1 + \frac{x}{\rho}\right) \left(\frac{1}{\rho} + kx\right) \left(\frac{p_0}{p}\right) v \frac{ds}{dt}$$

$$\frac{p_0}{p} \approx \left(1 - \frac{\Delta p}{p_0}\right)$$

$$v \approx \frac{ds}{dt} \frac{\rho + x}{\rho}$$

$$\Rightarrow \frac{d^2x}{ds^2} + \left(\frac{1}{\rho^2} + k\right) x \approx \frac{1}{\rho} \frac{\Delta p}{p} \approx 0$$

Assume $\Delta p \ll p$

Note that in general ρ and k are functions of s .

Equations of motion in dipole and quadrupole fields

Now consider x motion

$$\left(\frac{ds}{dt}\right)^2 \left(\frac{d^2x}{ds^2} - \left(\frac{1}{\rho} + \frac{x}{\rho^2}\right)\right) = -\left(1 + \frac{x}{\rho}\right)\left(\frac{1}{\rho} + kx\right)\left(\frac{p_0}{p}\right) v \frac{ds}{dt}$$

$$\frac{p_0}{p} \approx \left(1 - \frac{\Delta p}{p_0}\right)$$

$$v \approx \frac{ds}{dt} \frac{\rho + x}{\rho}$$

$$\Rightarrow \frac{d^2x}{ds^2} + \left(\frac{1}{\rho^2} + k\right)x \approx \frac{1}{\rho} \frac{\Delta p}{p} \approx 0$$

Assume $\Delta p \ll p$

Note that in general ρ and k are functions of s .

Finally we have Hill's equations

So, after some effort, we derived Hill's equations. They are linearised second order differential equations for the transverse variables x and z in dipole and quadrupoles fields in a particle accelerator.

$$\frac{d^2x}{ds^2} + \left(\frac{g}{B\rho} + \frac{1}{\rho^2} \right) x = 0 \qquad \frac{d^2z}{ds^2} - \frac{g}{B\rho} z = 0$$

In the equation for x , g comes from the quadrupoles and there is also natural focusing from the dipoles in the plane of curvature.

We can compactly write Hill's equations in both planes, denoting x or z by u and writing the position-dependent 'spring constant' as K

$$\frac{d^2u}{ds^2} + K(s)u = 0$$

Finally we have Hill's equations

$$\frac{d^2 u}{ds^2} + K(s)u = 0$$

Where the **periodic** functions of s describe the lattice

$$K_x = \frac{1}{B\rho} \frac{\partial B_z}{\partial x} + \frac{1}{\rho^2} \qquad K_x = k + \frac{1}{\rho^2}$$
$$K_z = -\frac{1}{B\rho} \frac{\partial B_x}{\partial z} \qquad K_z = -k$$

In these equations, ρ comes from the natural horizontal focusing in dipoles and the gradient term represents the strong focusing in quadrupoles.

PART TWO- SOLUTIONS TO HILL'S EQUATION

Solutions to Hill's Equations

- We will look for two kinds of solutions to Hill's equations
 - Piece-wise solutions for separate magnets (maps)
 - General solutions for the entire orbit (Courant-Snyder formalism)
- We will then compare the two kinds of solutions

Solution of piece-wise Hill's equations

$$\left. \begin{aligned} x'' + \left(k + \frac{1}{\rho^2} \right) x &= 0 \\ z'' - kz &= 0 \end{aligned} \right\} \text{These are our equations of motion.}$$

$$\left. \begin{aligned} x'' + K \cdot x &= 0 \\ K &= k + \frac{1}{\rho^2} \end{aligned} \right\} \text{If } K \text{ is constant then these equations look like the equation for a simple harmonic oscillator.}$$

So we know the solution from our studies of a mass on a spring!

Let's guess at

$$K > 0 \quad x(s) = c_1 \cos(\sqrt{K}s) + c_2 \sin(\sqrt{K}s)$$

$$\sqrt{K} = \omega$$

Take the derivatives and substitute into the equation of motion

$$x'(s) = -c_1 \sqrt{K} \sin(\sqrt{K}s) + c_2 \sqrt{K} \cos(\sqrt{K}s)$$

$$x''(s) = -c_1 K \cos(\sqrt{K}s) - c_2 K \sin(\sqrt{K}s) = -Kx(s)$$

Solution of piece-wise Hill's equations

So this solution seems to work.

NB We assumed $K > 0$ to get an oscillatory solution.

We can fix the integration constants from the initial conditions

$$\begin{aligned}x(0) &= x_0 \rightarrow c_1 = x_0 \\x'(0) &= x'_0 \rightarrow c_2 = \frac{x'_0}{\sqrt{K}}\end{aligned}$$

Now, we can write down the evolution of the variables x and x' in a region with constant and positive K as

$$\begin{aligned}K > 0 \quad x(s) &= x_0 \cos(\sqrt{K}s) + x'_0 \frac{1}{\sqrt{K}} \sin(\sqrt{K}s) \\x'(s) &= -x_0 \sqrt{K} \sin(\sqrt{K}s) + x'_0 \cos(\sqrt{K}s)\end{aligned}$$

Solution of piece-wise Hill's equations

What does this mean? Notice that the x' variable receives a negative kick if x_0 is positive, which corresponds to pointing the particle more towards the axis

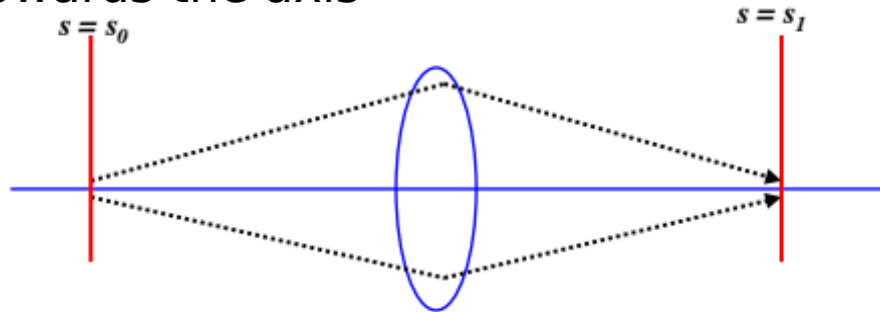

$$\theta = -\frac{q}{p} \int^l B ds$$

Also note that the final coordinates are linear combinations of the initial coordinates. This is a direct consequence of linearising the equations of motion.

We can write the solution very compactly as a matrix equation

$$\begin{pmatrix} x \\ x' \end{pmatrix}_1 = M_{\text{quad}} \cdot \begin{pmatrix} x \\ x' \end{pmatrix}_0$$
$$M_{\text{foc quad}} = \begin{pmatrix} \cos(\sqrt{K}s) & \frac{1}{\sqrt{K}} \sin(\sqrt{K}s) \\ -\sqrt{K} \sin(\sqrt{K}s) & \cos(\sqrt{K}s) \end{pmatrix}$$

So a particle is represented by x and x' , i.e. the vector (x, x')

Solution of piece-wise Hill's equations (with negative 'spring constant')

What about the case of $K < 0$? This has equation of motion

$$x'' - |K|.x = 0$$

And corresponds to a diverging solution. We remember our studies of a mass on a spring and use the sinh/cosh functions.

Which means the general solution to the equation of motion is

$$x(s) = c_1 \cosh(\sqrt{|K|}s) + c_2 \sinh(\sqrt{|K|}s)$$

This corresponds to a defocusing lens, and we can write the matrix as before.

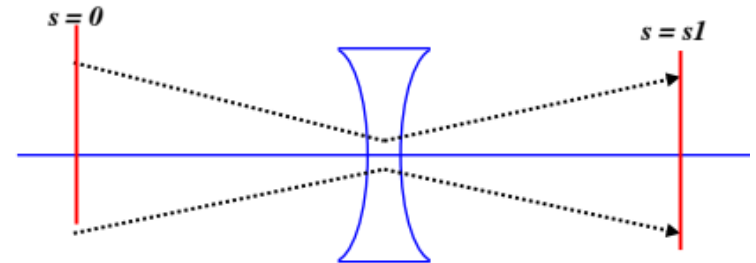

$$M_{\text{defoc quad}} = \begin{pmatrix} \cosh(\sqrt{|K|}s) & \frac{1}{\sqrt{|K|}} \sinh(\sqrt{|K|}s) \\ +\sqrt{|K|} \sinh(\sqrt{|K|}s) & \cosh(\sqrt{|K|}s) \end{pmatrix}$$

Focusing and defocusing quadrupoles

$$\left. \begin{aligned} x'' + \left(k + \frac{1}{\rho^2} \right) x &= 0 \\ z'' - kz &= 0 \end{aligned} \right\}$$

For a given quadrupole magnet, we have one sign of the constant k in one plane and the opposite sign in the other plane.

As expected the quadrupole focuses in one plane and defocuses in another (as the magnetic field is curl free).

We call a horizontally-focusing quadrupole a “**focusing quadrupole**”

$$\frac{e}{p} \frac{dB_z}{dx} = \frac{g}{B\rho} = k$$

A quadrupole with $dB_z/dx > 0$ gives $k > 0$, and so is focusing.

Similarly $dB_z/dx < 0$ gives $k < 0$, and so is defocusing.

Drift spaces

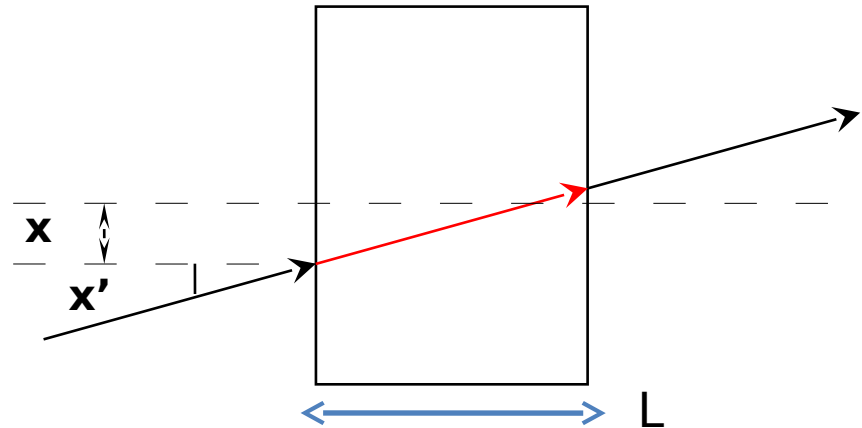

A drift space is a region of the beam line with no electromagnetic fields. We can figure out the evolution equations for x and x' by either simple geometry or taking a limit of the quadrupole matrices where $K \rightarrow 0$. Either way we find

$$x(s) = x_0 + x'_0 \cdot L$$

$$x'(s) = x'_0$$

Which we can write as a matrix very easily

$$M_{\text{drift}} = \begin{pmatrix} 1 & L \\ 0 & 1 \end{pmatrix}$$

The thin lens approximation

We know the matrix of a quadrupole can be written as

$$M_{\text{foc quad}} = \begin{pmatrix} \cos(\sqrt{K}s) & \frac{1}{\sqrt{K}} \sin(\sqrt{K}s) \\ -\sqrt{K} \sin(\sqrt{K}s) & \cos(\sqrt{K}s) \end{pmatrix}$$

Very often the magnet is short compared to its focal length

$$f = \frac{1}{Kl_q} \gg l_q$$

$$\theta = -\frac{q}{p} \int^l B ds$$

This means we can take the limit of a very short magnet, whilst keeping the focal length constant:

$$|K| \rightarrow \infty \quad l_q \rightarrow 0 \quad (Kl_q) = \text{const}$$

This gives us the thin lens matrices, which are very useful for quick calculations of a given accelerator structure (recall $K > 0$ for a horizontally focusing quadrupole, so $f > 0$)

$$M_{\text{thin}} = \begin{pmatrix} 1 & 0 \\ -\frac{1}{f} & 1 \end{pmatrix} \quad \frac{1}{f} = Kl_q$$

Recap of linear transport matrices

$$M_{\text{foc quad}} = \begin{pmatrix} \cos(\sqrt{K}s) & \frac{1}{\sqrt{K}} \sin(\sqrt{K}s) \\ -\sqrt{K} \sin(\sqrt{K}s) & \cos(\sqrt{K}s) \end{pmatrix}$$

$$M_{\text{defoc quad}} = \begin{pmatrix} \cosh(\sqrt{|K|}s) & \frac{1}{\sqrt{|K|}} \sinh(\sqrt{|K|}s) \\ +\sqrt{|K|} \sinh(\sqrt{|K|}s) & \cosh(\sqrt{|K|}s) \end{pmatrix}$$

$$M_{\text{drift}} = \begin{pmatrix} 1 & L \\ 0 & 1 \end{pmatrix}$$

$$M_{\text{thin}} = \begin{pmatrix} 1 & 0 \\ -\frac{1}{f} & 1 \end{pmatrix}$$

An aside: What are the determinants of these matrices? What does that imply?

A pure dipole

To get the matrix for a dipole, we start from the matrix of a quadrupole

$$M_{\text{foc quad}} = \begin{pmatrix} \cos(\sqrt{K}s) & \frac{1}{\sqrt{K}} \sin(\sqrt{K}s) \\ -\sqrt{K} \sin(\sqrt{K}s) & \cos(\sqrt{K}s) \end{pmatrix}$$

In the horizontal plane, a dipole gives a pure bending contribution to K

$$K = \frac{1}{\rho^2}$$

And so for a pure bend of length l we obtain

$$M_{\text{dipole,x}} = \begin{pmatrix} \cos \theta & \rho \sin \theta \\ -\frac{1}{\rho} \sin \theta & \cos \theta \end{pmatrix} \quad \theta = l/\rho$$

We can see the expected geometric focusing in the plane of the bend

NB The matrix in the vertical plane is a drift

The doublet

Consider a doublet made from a focussing and a defocussing quadrupole:

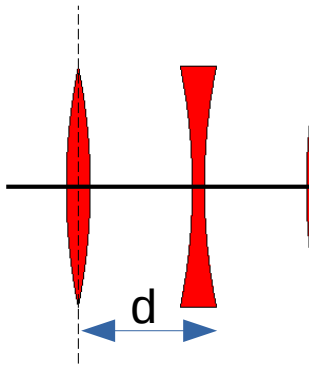

Focal lengths f_1 f_2
Separation d

$$M_{\text{thin}} = \begin{pmatrix} 1 & 0 \\ -\frac{1}{f} & 1 \end{pmatrix}$$

If we multiply the thin lens matrices, the focal length for the combined system is easily obtained from the (2,1) element of the composite matrix

$$\frac{1}{f} = \frac{1}{f_1} + \frac{1}{f_2} - \frac{d}{f_1 f_2}$$

If we let $f_1 = -f_2$ then the leading terms cancel and the doublet is **focusing in both planes at the same time**: i.e. $f = (f_1)^2 / d$ for x and z . This is exactly the behaviour we want in our accelerator!

This concept led to the invention of the alternating gradient (or strong focusing) principle and is the basic building block of most modern accelerator lattices.

Maps

A **map** relates an initial state vector to a final state vector

$$X(s_1) = M(s_1|s_0)X(s_0)$$

For the linear case, the map can be represented as a matrix.

For non-linear systems we cannot use a matrix to represent the map.

Non-linear representations include Taylor maps or Lie maps.

See more advanced courses for details...

The one-turn map

We know how to combine maps

$$M(s_2|s_0) = M(s_2|s_1)M(s_1|s_0)$$

One particularly useful map is the **one-turn map**

If we start at location s in a ring of circumference C , then the one turn map is defined as one turn around the ring

$$M(s + C|s)$$

This means the map for N revolutions of the ring is found from N applications to a given particle state vector of the one turn map

$$M(s + C|s)^N$$

A single particle for a single turn

It is simple to implement these maps in a computer simulation.

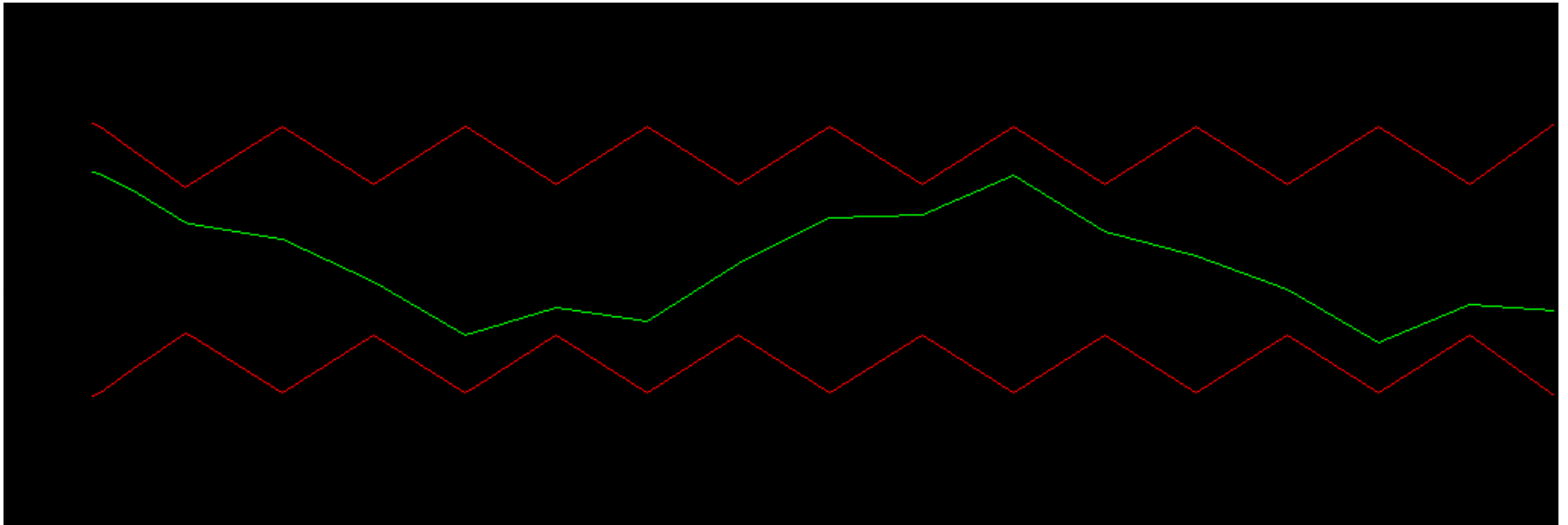

Tracking particles for many turns

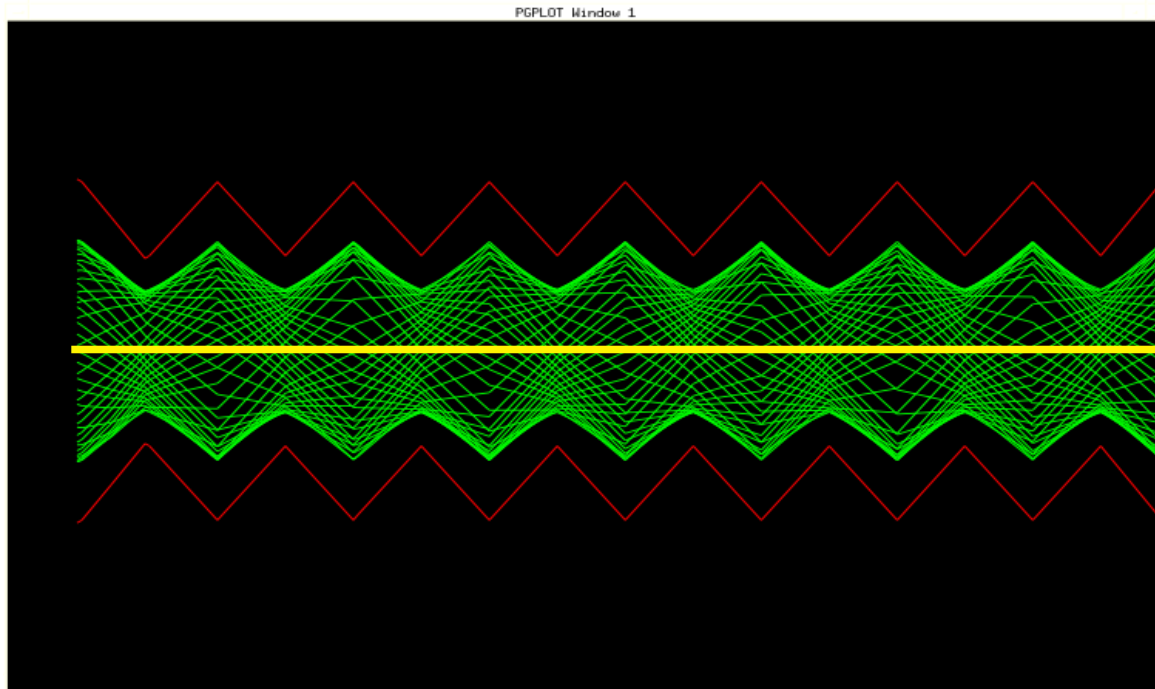

Looking at lots of particles over many turns we see they trajectories form an envelope for the beam.

Note we can see the straight reference particle (yellow) in the above plot, which is not a real particle.

Back to Hill's equation

$$x''(s) + K(s).x(s) = 0$$

Hill's equation is a second order differential equation for a system with periodic focusing properties

It's like a pendulum or mass on a spring but the restoring force is not constant. It's a periodically-varying force (often seen in planetary dynamics).

If the closed orbit has periodicity L , then so does the function $K(s)$

$$K(s + L) = K(s)$$

So we can expect a kind of quasi-harmonic oscillation, where the frequency and amplitude depend on the location in the ring and show periodicity similar to that of the function $K(s)$...

The Courant-Snyder formalism

In the Courant-Snyder formalism we assume a solution of Hill's equation inspired by our intuition of a position-dependent amplitude and phase. It is this....

$$x(s) = \sqrt{\epsilon \beta(s)} \cos(\psi(s) + \psi_0)$$

- $\beta(s)$ determines the amplitude and depends on the position around the accelerator. It's not the relativistic β
- $\psi(s)$ is a position-dependent phase
- ϵ is a constant. Because Hill's equation is linear, the constant does not appear in it. We'll see later why ϵ is called the emittance.

$\beta(s)$ is the key quantity in the Courant-Snyder formalism and has many names : the beta function, the beam envelope function, the Courant-Snyder beta function, the amplitude function and so on. It is always positive.

We'll see that $\beta(s + L) = \beta(s)$

A differential equation for the beta function

If we take the derivatives of the Courant-Snyder solution and substitute them back into the equation of motion, we find we get two terms, one proportional to cosine and one proportional to sine. This is a good exercise to do!

The coefficients of these terms must vanish separately. We obtain two differential equations:

$$\left. \begin{aligned} \frac{1}{2}(\beta\beta'' - \frac{1}{2}\beta'^2) - \beta^2\psi'^2 + \beta^2K &= 0 \\ \beta'\psi' + \beta\psi'' &= 0 \end{aligned} \right\}$$

The second equation can be integrated immediately:

$$\beta'\psi' + \beta\psi'' = (\beta\psi)'$$

and we are free to choose the integration constant to be unity

$$\beta\psi' = 1$$

A differential equation for the beta function

If we take the derivatives of the Courant-Snyder solution and substitute them back into the equation of motion, we find we get two terms, one proportional to cosine and one proportional to sine. This is a good exercise to do!

The coefficients of these terms must vanish separately. We obtain two differential equations:

$$\frac{1}{2}(\beta\beta'' - \frac{1}{2}\beta'^2) - \beta^2\psi'^2 + \beta^2K = 0$$

$$\beta'\psi' + \beta\psi'' = 0$$

The second equation can be integrated immediately:

$$\beta'\psi' + \beta\psi'' = (\beta\psi)'$$

and we are free to choose the integration constant to be unity

$$\beta\psi' = 1$$

The Courant-Snyder (or lattice) functions

We then immediately have the result for the phase function

$$\psi(s) = \int_0^s \frac{ds}{\beta(s)}$$

So this position-dependent phase is given by an integral of the beta function along the beam line. i.e. knowing the beta function means we can compute the phase function.

We can now eliminate the phase function from the first of the differential equations to get a differential equation for the beta function

$$\frac{1}{2}\beta\beta'' - \frac{1}{4}\beta'^2 + \beta^2 K = 1$$

So knowing the distribution of focusing strengths along a beam line determines beta.

Finally, we define two additional functions (lattice functions)

$$\alpha(s) = -\frac{1}{2} \frac{d\beta(s)}{ds} \quad \gamma(s) = \frac{1 + \alpha^2(s)}{\beta(s)}$$

Applying the initial conditions

Once the beta function is known, and hence α and γ , the motion of a single particle is completely determined by specifying the emittance and the initial phase factor of the particle. So we have

$$x(s) = \sqrt{\epsilon \beta(s)} \cos(\psi(s) + \psi_0)$$

$$x'(s) = -\frac{\sqrt{\epsilon}}{\sqrt{\beta}} [\alpha(s) \cos(\psi(s) + \psi_0) + \sin(\psi(s) + \psi_0)]$$

We can combine these two equations to give the quantity

$$\beta x' + \alpha x = -\sqrt{\epsilon \beta} \sin(\psi + \psi_0) \longleftarrow \text{c.f. } x$$

Which means we can write an expression which is invariant for a particle

$$x^2 + (\beta x' + \alpha x)^2 = \epsilon \beta$$

Or, expanding the square, we arrive at the famous result

$$\gamma x^2 + 2\alpha x x' + \beta x'^2 = \epsilon$$

Applying the initial conditions

Once the beta function is known, and hence α and γ , the motion of a single particle is completely determined by specifying the emittance and the initial phase factor of the particle. So we have

$$x(s) = \sqrt{\epsilon \beta(s)} \cos(\psi(s) + \psi_0)$$

$$x'(s) = -\frac{\sqrt{\epsilon}}{\sqrt{\beta}} [\alpha(s) \cos(\psi(s) + \psi_0) + \sin(\psi(s) + \psi_0)]$$

We can combine these two equations to give the quantity

$$\beta x' + \alpha x = -\sqrt{\epsilon \beta} \sin(\psi + \psi_0)$$

Which means we can write an expression which is invariant for a particle

$$x^2 + (\beta x' + \alpha x)^2 = \epsilon \beta$$

Or, expanding the square, we arrive at the famous result

$$\gamma x^2 + 2\alpha x x' + \beta x'^2 = \epsilon$$

The emittance is an invariant

Let's look at this equation carefully.

$$\gamma x^2 + 2\alpha x x' + \beta x'^2 = \epsilon$$

For every point in the accelerator we have a value of the functions α , β and γ . They depend on the lattice.

At any point, if we combine the particle position and angle with these lattice functions we get an invariant, which was the emittance we saw in the solution to Hill's equations in the Courant-Snyder formalism.

As the particle moves to the next location in the accelerator, where we have different lattice functions, it get a different position and angle. However if we form this function again at the new location we get the same value as before.

In other words, the emittance is a constant of the particle's motion.

The phase-space ellipse

$$\gamma x^2 + 2\alpha x x' + \beta x'^2 = \epsilon$$

This function describes an inclined ellipse in the (x, x') plane, with the size and orientation of the ellipse described by the values of α , β and γ .

β controls the extent along the x axis, γ controls the extent along the x' axis, α determines the ellipse orientation

(example - what values of α , β and γ give you a perfect circle?)

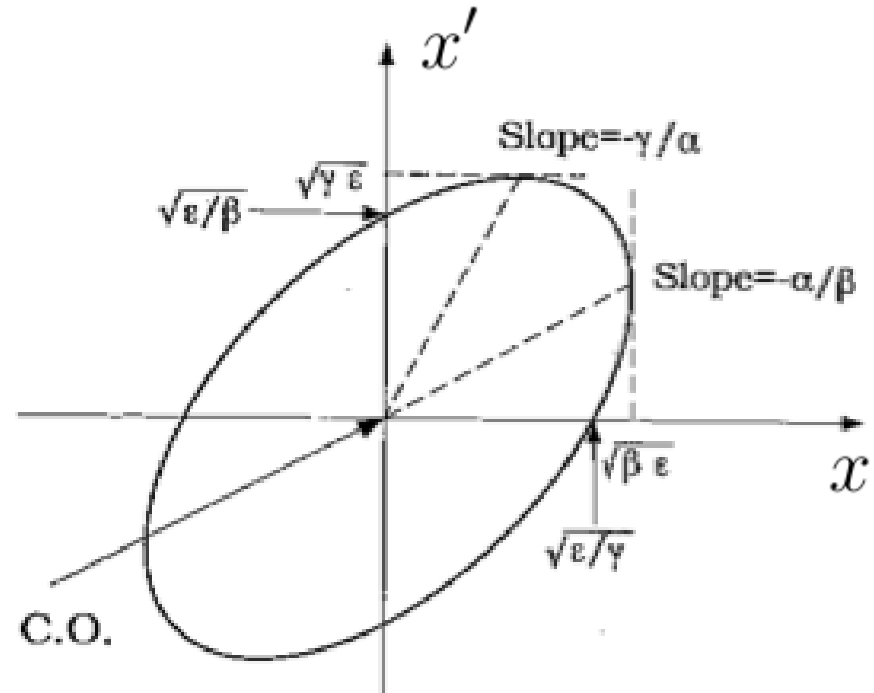

The area of the ellipse is given by

$$A_x = \pi\epsilon_x$$

Which means the area of an ellipse transcribed by a given particle is **constant**.

A stroboscopic plot of a particle turn after turn after turn

Recall that the lattice parameters are functions of the focusing of the lattice, so every point in the lattice has a value of the lattice functions and so every point in the lattice has its own orientation and eccentricity of the ellipse.

A given particle has its own value of the emittance which fixes the area of the ellipse it moves around.

Consider sitting at a fixed point in the ring and watching a single particle turn after turn after turn.

$$(x_1, x_1') \quad (x_2, x_2') \quad (x_3, x_3') \quad (x_4, x_4')$$

All these points lie on the ellipse.

Note the particle jumps around the ellipse and does not move around it continuously

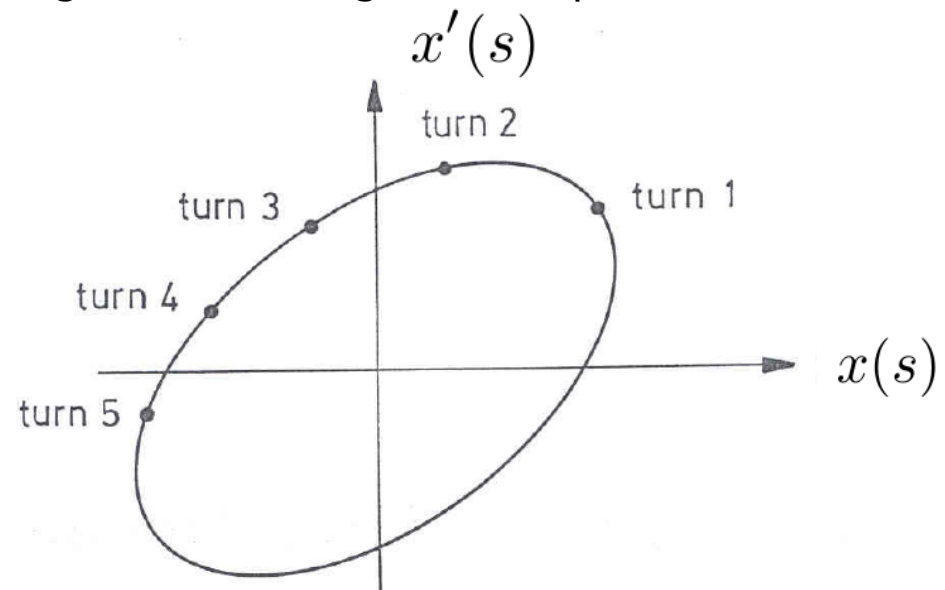

Moving along a beam line

As we move along the beam line the ellipse inclination and eccentricity change, but the particle always lies on the ellipse.

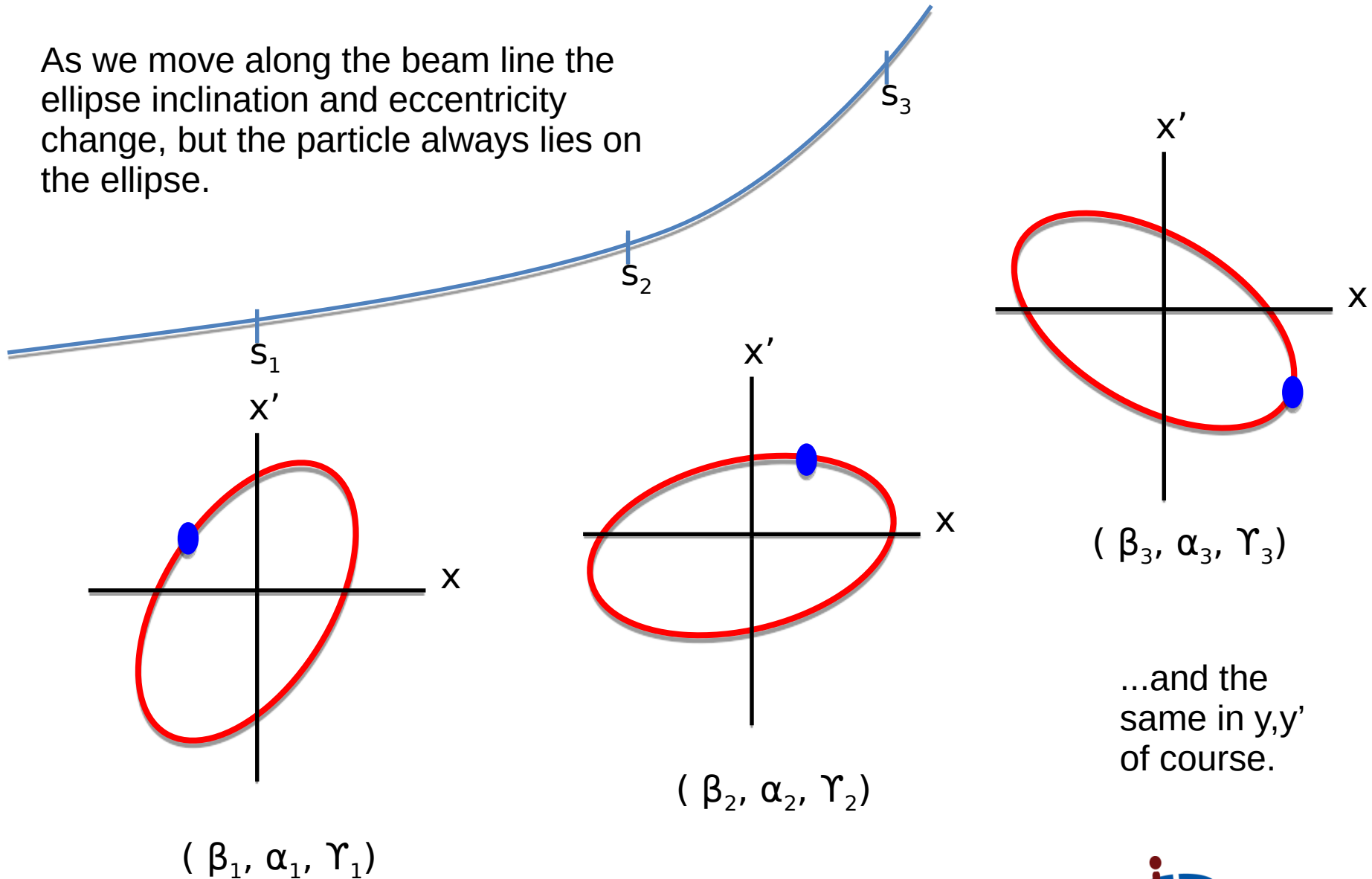

...and the same in y, y' of course.